

VAMP 230, VAMP 255 and VAMP 257

Feeder and Motor manager series



MAIN CHARACTERISTICS

- **Complete protection**
Comprehensive selection of protection functions for distribution network overhead line feeders, cable feeders, motor feeders including large motors, capacitor banks and reactors.
- **Total control**
Extensive bay control functionality including local and remote control of six objects and status supervision of another two objects.
- **Comprehensive measurements**
Wide range of measurement functions including phase-to-earth, phase-to-phase voltages, currents, frequency, active, reactive and apparent power, active and reactive energy imported and exported, power factor, negative phase sequence current, etc.
- **Power quality assessment**
Power quality assessment and analysis including supervision of harmonics up to the 15th order, THD as well as voltage swells and sags.
- **Fault location**
Integrated fault location with distance indication for short circuits in distribution networks irrespective of power network earthing system and earth-faults in compensated networks.
- **Ultra-fast Arc flash protection**
Unique integrated arc fault protection functionality for enhanced safety of switchgear, substations, people and property.
- **Extensive communication**
Large number of supported communication protocols including IEC 60870-5-101, IEC 60870-5-103, Modbus TCP, Modbus RTU, Profibus DP, TCP/IP, SPA-bus slave, DNP3.0, DNP TCP, IEC 61850, Device Net or Ethernet /IP.
- **Easy handling and management**
Easy commissioning, configuration and operation of the relays supported by the straight-forward VAMPSET relay management software

The protection relays of the VAMP Series are used for the selective protection of overhead line feeders, cable feeders, motor feeders, capacitor banks, reactors and busbars in power system distribution substations, power plants, industrial power systems, marine and offshore installations. Besides a comprehensive range of standard protection functions the VAMP series also offers bay control, measurement, primary circuit monitoring and communication functionality.

A unique feature of the VAMP relays is the arc fault protection system integrated into the relays. The extremely fast arc fault protection option adds a new dimension to the total safety of the installation and the reliability of the protection system.

Further, VAMP relays incorporate power quality assessment based on fast Fourier transform and fault spot location based on fault reactance calculation.

Customer specific configuration is obtained by freely configurable mimic display and logic programming by means of the easy-to-use VAMPSET software.

After a network fault the relays support a subsequent fault analysis by providing event sequence recordings, fault value registration and disturbance recorder capability.

Comprehensive functionality and communication makes VAMP an ideal choice throughout the world.

Quick selection table

	VAMP 257		VAMP 255		VAMP 230	
Analog measurement	5 x I 3 x U		5 x I 3 x U		5 x I 3 x U	
Digital inputs / Trip relays	V257 xx6 E/Fxx V257 xx7 E/Fxx V257 xx8 E/Fxx V257 xx9 E/Fxx	20 / 4 28 / 8 20 / 14 28 / 8	V255 xxx E/Fxx	20 / 4	V230 xxx E/Fxx	8 / 2
Alarm relays	5		5		5	
Self-supervision contacts	1		1		1	

VAMP 230, 255 and 257 are all suitable for applications where reliable control and protection is needed. The features of the products vary in the number of digital inputs and outputs and in the number of analog measuring channels.



Power quality assessment

The power quality of electrical networks has become increasingly important in modern society. Sophisticated loads, such as computers and automation systems, require an uninterrupted supply of “clean” electricity.

The VAMP feeder managers are provided with integrated power quality measuring and analysis functions, which help to reduce variations in the quality of the distributed power. The terminal supervises the harmonics of phase currents and voltages from the 2nd to the 15th order and the THD (Total Harmonic Distortion).

One of the most important power quality functions is the monitoring of voltage sags and swells. The VAMP feeder terminal provides separate monitoring logs for sags and swells. The fault log comprises four registers for voltage sags and another four for voltage swells.

The disturbance recorder functionality can be used for recording measured currents, voltages and for recording status information of digital inputs and outputs, also including the signals of the arc protection system. The time stamped recordings provide indispensable information for the subsequent analysis of a fault situation.

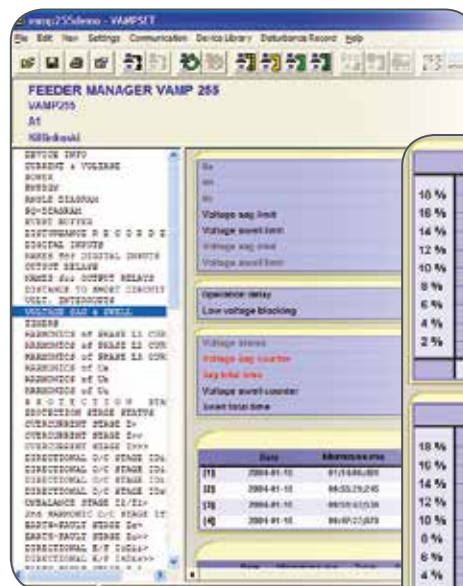

Example of harmonics content and voltage sag/swell registration obtained from a VAMP feeder manager.

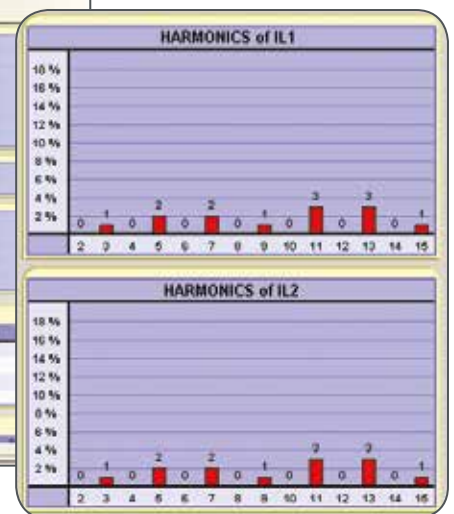

Many functions in modern society rely heavily on electric energy and therefore the quality of the energy supply is gaining increased importance

Fault location

The feeder manager includes a sophisticated stand-alone fault location function. The algorithm used can accurately locate **short-circuits** in any type of distribution networks. The fault location is given as a reactance value, and the distance to the fault is also displayed on the local HMI, optionally as a mA signal and as a message over the communication system. The distance value can be exported, for example, as an event to a DMS (Distribution Management System). The system can then locate the fault. If a DMS is not available, the distance to the fault is displayed in kilometres, as well as a reactance value. The calculation of the distance is based on reactance measurement and homogenous lines with a known line reactance. This feature of the VAMP relay is a very cost-effective upgrade of an existing system.

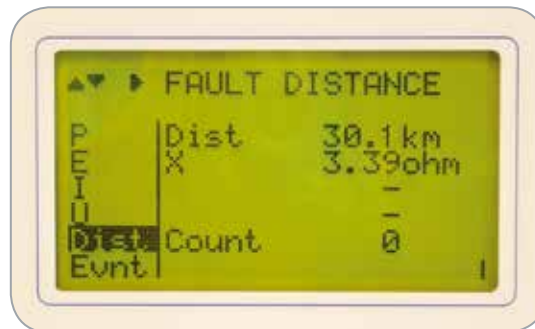

VAMP feeder managers provide accurate short-circuit fault location regardless of the MV network earthing method.

Measurement and monitoring functions

The VAMP feeder managers offer a complete set of measurement functions to replace the conventional metering functions of traditional switchgear and control gear installations. The measurement functions cover voltages, currents, frequency, power, energy, harmonics, voltage sags and swells, etc. The measured information can be read via the communication bus, via the configurable analogue outputs and energy measurements can be transferred via binary pulse outputs. The accuracy of the current and voltage measurements is greater than +/- 0.5% whereas it is +/- 1 % for active and reactive power.

Besides the measurement functions, the feeder manager also encompasses a set of system supervision functions. All current and voltage transformer circuits are continuously supervised, as are the trip circuits from the feeder manager to the circuit breaker trip coils. The wear and tear of the circuit breaker is also continuously monitored providing an alarm when the circuit breaker needs maintenance.

The critical data like latest events, voltage sag/swell logs, energy counters are stored in the non-volatile memory to guarantee preservation of the information in case the relay auxiliary power is lost.

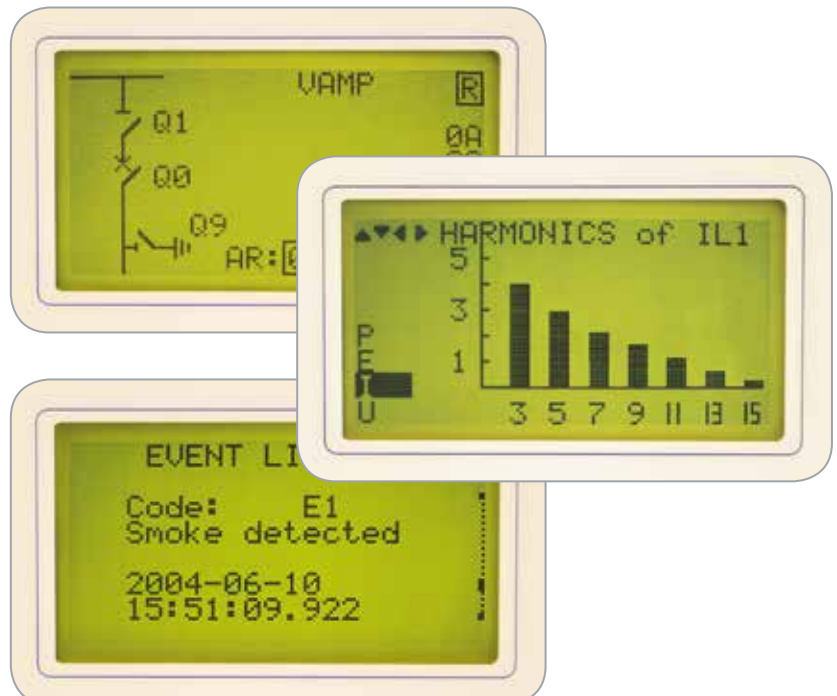

The easy-to-use VAMP feeder managers are characterized by clear text parameters and multi-lingual support to facilitate normal relay management functions.

Communication

VAMP is a communication expert with a wide experience in interfacing with different system integrators' and SCADA suppliers' RTUs, PLCs, gateways etc. using different protocols. Flexible adaptation of the communication protocols together with powerful and easy to use software tools are the key of successful integration. VAMP protection relays and the VAMPSET tool provide access to practically any power system information you may need.

The VAMP feeder manager series feature three serial communication ports, two on the rear plate for connection to the plant control system and maintenance terminal and one RS 232 port on the front panel for connection of a laptop computer.

The VAMP relays communicate using the most common industrial and utility standard open communication protocols. Both the communication protocol and physical media to be used can be freely selected after acquisition of the protection devices. Therefore VAMP relays are a perfect choice also when the communication capability of the relays is to be utilized sometimes later. You may select the protocol and media according to the system you will apply.

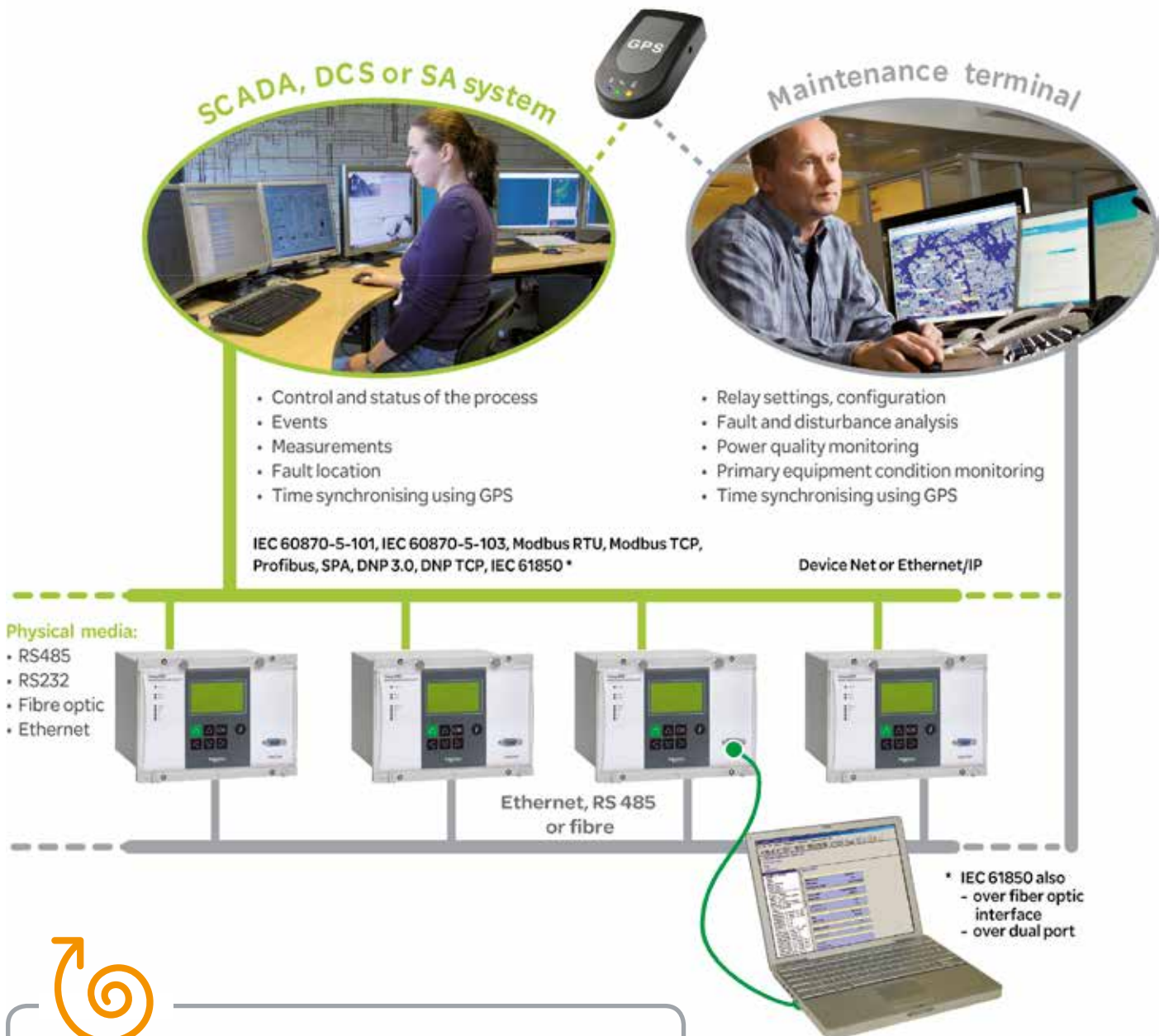

The VAMP relays are easily interfaced with any renowned and recognized SCADA system

VAMPSET setting and configuration tool

VAMPSET is a user-friendly, free-of-charge relay management software for setting parameters and configuring VAMP relays. Via the VAMPSET software relay parameters, configurations and recorded relay data can be swapped between the operator's PC and the VAMP relays. Supporting the COMTRADE format VAMPSET also incorporates tools for analyzing relay events, waveforms and trends from data recorded by the relays, e.g. during a network fault situation.

Using a standard serial cable the PC running VAMPSET connects to the front or rear port of the VAMP relays. The VAMPSET software also supports TCP/IP communication via an optional 10Base-T connection. Featuring true multi-language support the software runs on Windows 7/Vista/XP/2000/NT/98/55 without any need for configuration of the PC. The VAMPSET software is future-proof supporting coming updates and new VAMP products.

The VAMPSET software size is approximately 1Mbyte; you may conveniently distribute it by e-mail saving valuable transport and waiting time – and money.

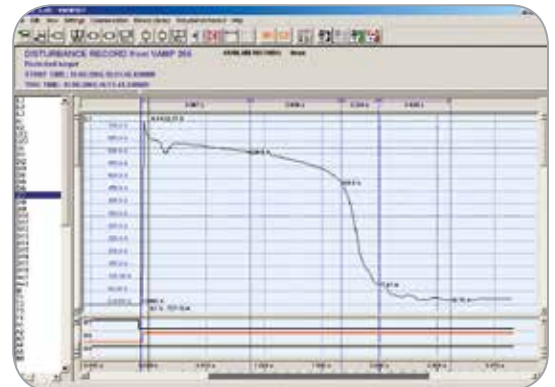

A register stores the motor start-up values (start current, duration etc.) significantly facilitating the correct setting of the relay even if critical motor data is unavailable from the manufacturer.

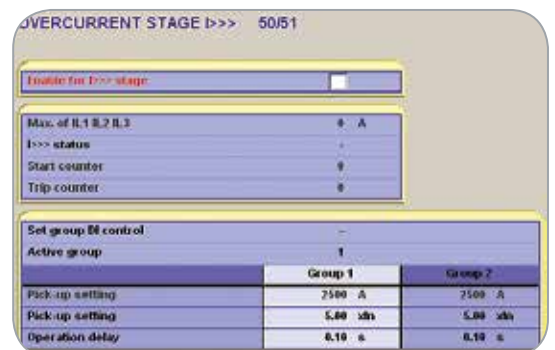
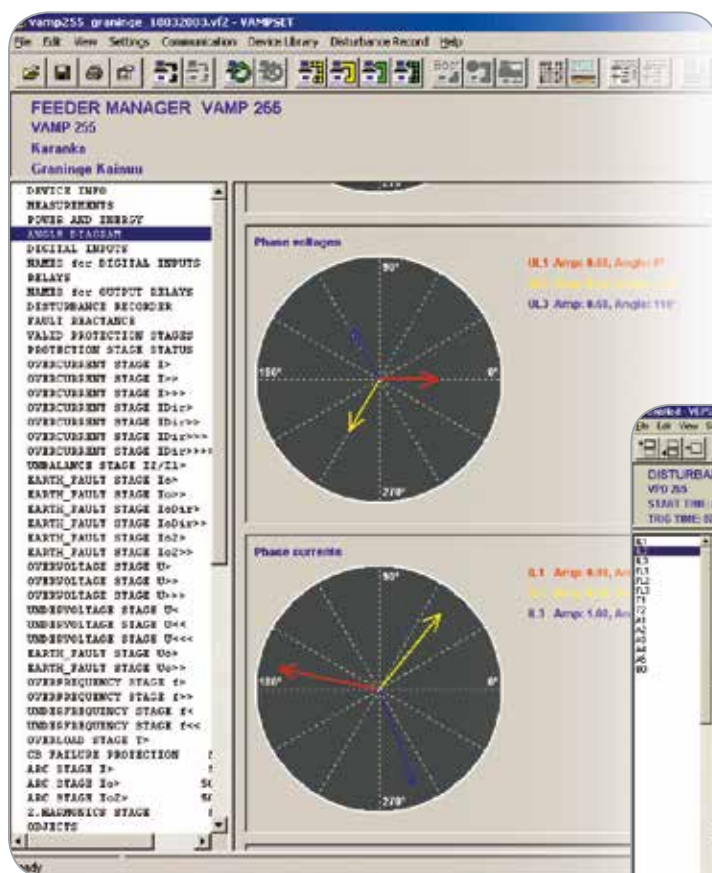

Protection setting example

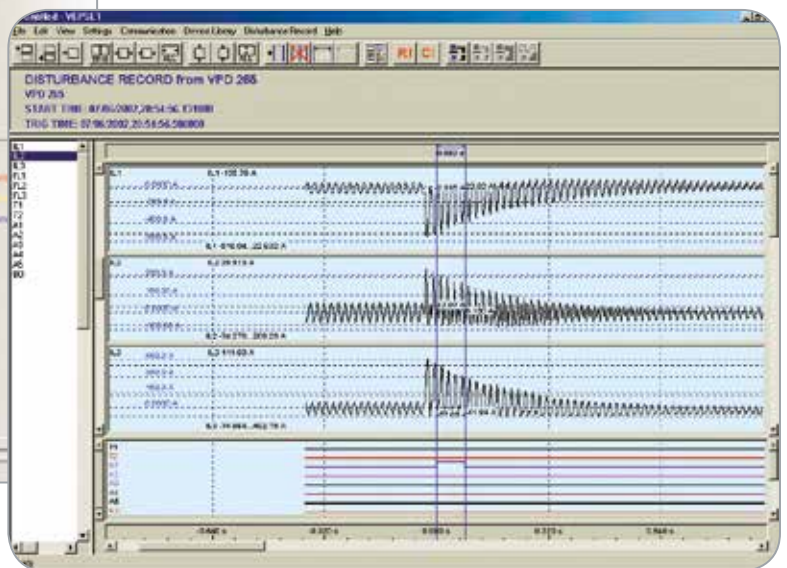

The phase sequences for currents and voltages can be read on-line from the clear and explicit windows for easy commissioning of the relay system.

Functionality

	IEEE no	IEC symbol	Function name		VAMP 230	VAMP 255	VAMP 257
Protection functions	50/51	3I>, 3I>>, 3I>>>	Overcurrent	IEC, IEEE programmable curves	●	●	●
	50N/51N	I ₀ >, I ₀ >>, I ₀ >>>, I ₀ >>>>	Earth fault		●	●	●
	67	I _{dir} >, I _{dir} >>, I _{dir} >>>, I _{dir} >>>>	Directional overcurrent		●	●	●
	67N	I ₀ >, I ₀ >>	Directional earth fault	●	●	●	
	67NT	I _{0T} >	Intermittent transient earth fault	●	●	●	
	46R	I ₂ /I ₁ >	Broken line	●	●	●	
	46	I ₂ >	Current unbalance	●	●	●	
	47	I ₂ >>	Incorrect phase sequence	●	●	●	
	48	I _{st} >	Stall	●	●	●	
	66	N>	Frequent start	●	●	●	
	37	I<	Undercurrent	●	●	●	
	49	T>	Thermal overload	●	●	●	
	59N	U ₀ >, U ₀ >>	Zero sequence voltage	●	●	●	
	59	U>, U>>, U>>>	Overvoltage	●	●	●	
	27	U<, U<<, U<<<	Undervoltage	●	●	●	
	81H/ 81L	f<, f>><<	Over frequency and under frequency	●	●	●	
	81L	f<, f<<	Under frequency	●	●	●	
	81R	df/dt	Rate of change of frequency	●	●	●	
	68	I _{2f}	Inrush and cold load	●	●	●	
	32	P<, P<<	Reverse power	●	●	●	
	79		Auto reclose function	●	●	●	
	50BF	CBFP	Circuit-breaker failure	●	●	●	
	50ARC/50NARC	Arcl>, Arcl ₀ >, Arcl ₀₂ >	Arc fault protection	●	●	● *	
25		Capacitor bank unbalance	●	●	●		
86		Synchrocheck	●	●	●		
99	Prg1...8	Latched trip	●	●	●		
		Programmable stages	●	●	●		
Measurement and monitoring functions		3I	Three-phase current	●	●	●	
		I ₀	Neutral current	●	●	●	
		I ₂	Current unbalance	●	●	●	
		I _L	Average and maximum demand current	●	●	●	
		3U	Phase-to-earth, phase-to-phase voltages	●	●	●	
		U ₀	Residual voltage	●	●	●	
		U ₂	Voltage unbalance	●	●	●	
		X _{fault}	Short-circuit fault reactance, Fault location	●	●	●	
		X _{fault}	Earth-fault reactance, compensated network	●	●	●	
		f	System frequency	●	●	●	
		P	Active power	●	●	●	
		Q	Reactive power	●	●	●	
		S	Apparent power	●	●	●	
		E ₊ , E ₋	Active Energy, exported / imported	●	●	●	
		Eq ₊ , Eq ₋	Reactive Energy, exported / imported	●	●	●	
		PF	Power factor	●	●	●	
			Phasor diagram view of voltages	●	●	●	
			Phasor diagram view of currents	●	●	●	
			2nd to 15th harmonics and THD of currents	●	●	●	
			2nd to 15th harmonics and THD of voltages	●	●	●	
			Condition monitoring CB wear	●	●	●	
			Condition monitoring CT supervision	●	●	●	
			Condition monitoring VT supervision	●	●	●	
		Trip Circuit Supervision (TCS)	●	●	●		
		Trip Circuit Supervision with 4 x DI for T5...T8			●		
		Voltage interruptions	●	●	●		
		Voltage sags and swells	●	●	●		
		Disturbance recorder	●	●	●		
		Temperature	●	●	●		
Communication		IEC 60870-5-101	IEC 60870-5-101	●	●	●	
		IEC 60870-5-103	IEC 60870-5-103	●	●	●	
		Modbus TCP	Modbus TCP	●	●	●	
		Modbus RTU	Modbus RTU	●	●	●	
		Profibus DP	Profibus DP	●	●	●	
		SPA-bus communication	SPA-bus communication	●	●	●	
		DNP 3.0	DNP 3.0	●	●	●	
		IEC 61850	IEC 61850	●	●	●	
		Human-Machine-Communication, display	Human-Machine-Communication, display	●	●	●	
		Human-Machine-Communication, PC	Human-Machine-Communication, PC	●	●	●	
Hardware			Number of phase current CTs	3	3	3	
			Number of residual current CTs	2	2	2	
			Number of voltage input VTs	3	3	3	
			Number of digital inputs	6	18	18/20/26/28	
			Number of extra digital inputs with the DI19/DI20 option	2	2	2	
			Integrated trip supervision inputs			0/4/4	
			Number of trip outputs	2	4	8/12/18	
			Number of alarm outputs (including IF)	6	6	2 *	
			Number of optional mA outputs	4	4		
			RTD inputs	4-16	4-16	4-16 *	

*) Option

Arc flash protection

Whether the time-grading or blocking based protection coordination principle is used, the traditional protection systems may not provide fast enough protection of substation faults. Further, high-impedance type of earth-faults may cause prolonged operation times of earth-fault relays leading to the significant release of the arcing energy. These facts pose a considerable risk to human beings and economical assets. By applying a modern, high-speed arc flash protection system the damage may be considerably reduced. Such an arc flash protection system is an optional feature that can be incorporated in all current measuring VAMP relays.

The VAMP relays measure the fault current. If the arc flash protection option is selected the relays also measure light via arc sensor channels monitoring the whole switchgear. Should an arcing fault occur in the switchgear the arc flash protection system provides extremely fast tripping of the circuit breaker. The fault will be prevented from spreading and quickly isolated, which may save human lives and valuable economical assets.

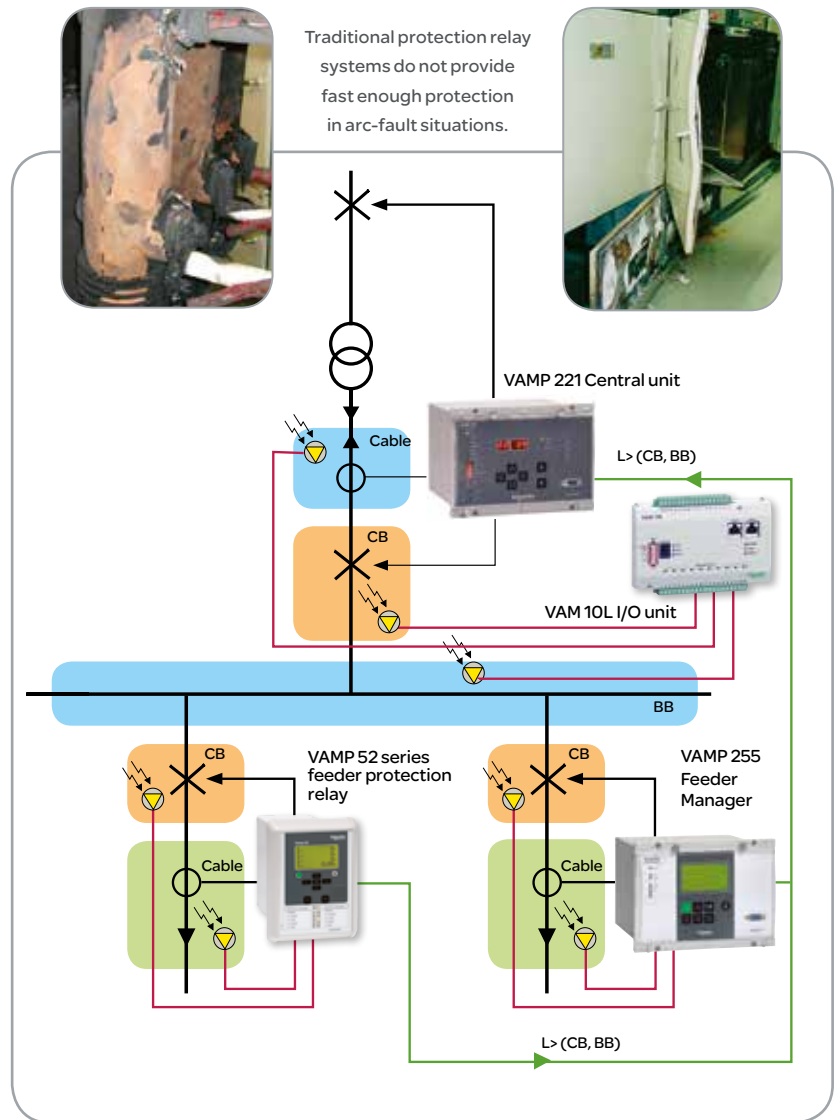

The VAMP arc flash protection devices also provide a cost efficient high-speed MV busbar protection.

External LED module VAM 16D

The external LED module provides 16 extra LED-indicators in external casing. The module is connected to the serial port of the relays front panel.

Door closed	CT alarm
Overcurrent	VT alarm
Earth-fault	CB wear
Under frequency	trip circuit supervision
Thermal overload	Smoke alarm
Arc cable compartment	376 low
Arc bus bar	
AR progress	AR final trip

All signals of the feeder manager's output matrix are available to the external LED module. For every LED you can connect one or more signals.

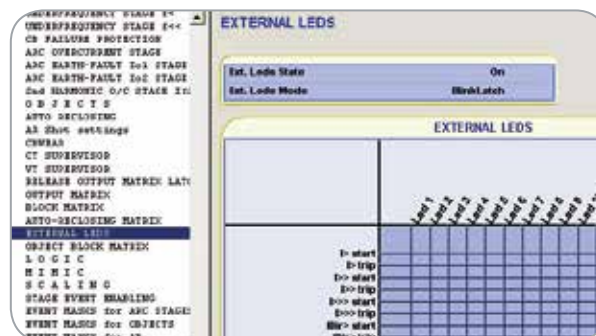

The phase sequences for currents and voltages can be read on-line from the clear and explicit windows for easy commissioning of the relay system.

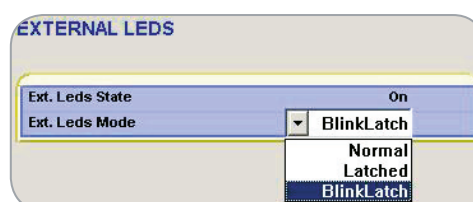

The display mode is either Latched i.e. signal following, Latched or Blink latched.

Programmable stages

There are now eight stages available to use with various applications. Each stage can monitor any analogue (measured or calculated) signal and issue start and trip signals. Programmable stages extend the protection functionality of the manager series to a new level. For example, if four stages of frequency are not enough, with programmable stages, the maximum of 12 can be reached. Other examples are using the stages to issue an alarm when there are a lot of harmonics (THD) or indicating reverse power condition.

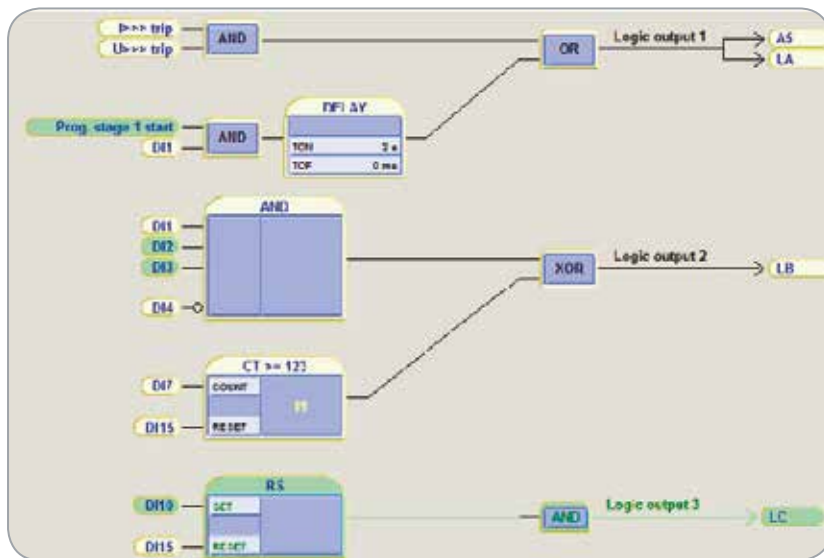

Programmable logic:

The logic editor has colours to enable viewing of active statuses. Furthermore, each input status can be also seen on-line in VAMPSET view.

Synchrocheck

VAMP 257, 255 and 230 feeder / motor managers include a function that will check synchronism when the circuit-breaker is closed. The function will monitor voltage amplitude, frequency and phase angle difference between two voltages. Since there are two stages available, it is possible to monitor three voltages. The voltages can be busbar and line or busbar and busbar (bus coupler). Furthermore, the voltage check functionality is included.

PROGRAMMABLE STAGE 1

Enable for Prg1

Priority 20 ms

Programmable stage 1 status -

Enable forcing

Coupling THD L1

THD L1 10.0 %

Compare condition >

Set group DI control -

Group	Group 1	Group 2
Pick-up setting	15.0 %	100.0 %
Pick-up setting	15 %	100 %
Operation delay	0.50 s	0.50 s

Common settings

Hysteresis 3.0 %

No compare limit for mode < 0 %

PROGRAMMABLE STAGE 2

Enable for Prg2

Priority 20 ms

Programmable stage 2 status -

Enable forcing

Coupling P

P 201 kW

Compare condition <

Set group DI control -

Group	Group 1	Group 2
Pick-up setting	-114 kW	5718 MW
Pick-up setting	-2 %5n	100 %5n
Operation delay	0.50 s	0.50 s

Common settings

Hysteresis 0.5 %

No compare limit for mode < 0 %5n

SYNCHROCHECK 1 25

Enable for Sync1

Voltage input U12/U12y

	Frequency	Voltage	Angle
Side 1:	49.675 Hz	45.3 %Un	30.0 °
Side 2:	49.675 Hz	47.5 %Un	30.8 °
Diff:	0.000 Hz	2.2 %Un	0.9 °

STATUS

Voltage status	LL
Sync status	No
Request time status	-
Sync requests	0
Sync counter	0
Fail counter	0

CONTROL SETTINGS

CB object	Obj1
Sync mode	Sync
Voltage check mode	LD
CB close time	0.10 s
Bypass DI	-
Bypass	0
CB CONTROL	-
Sync info for mimic display	<input checked="" type="checkbox"/>

Typical applications

VAMP 230 / 255 / 257

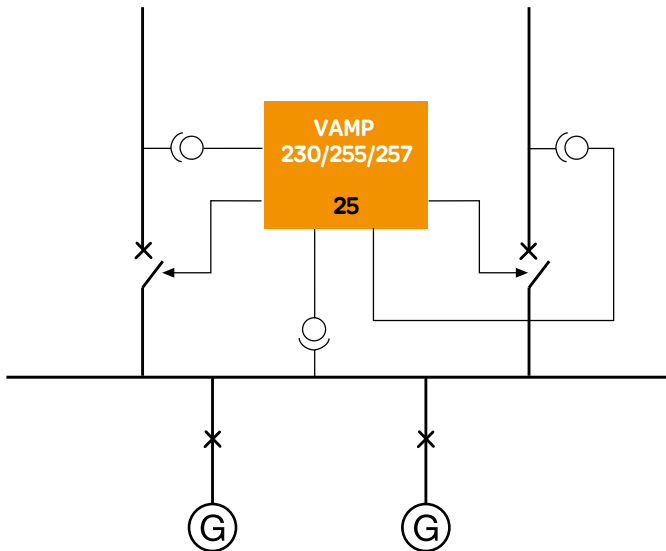

Standard feature of the VAMP 230 / 255 / 257 feeder managers incorporate voltage and synchrocheck functionality. The feeder manager allows safe connection of three alternative power sources together.

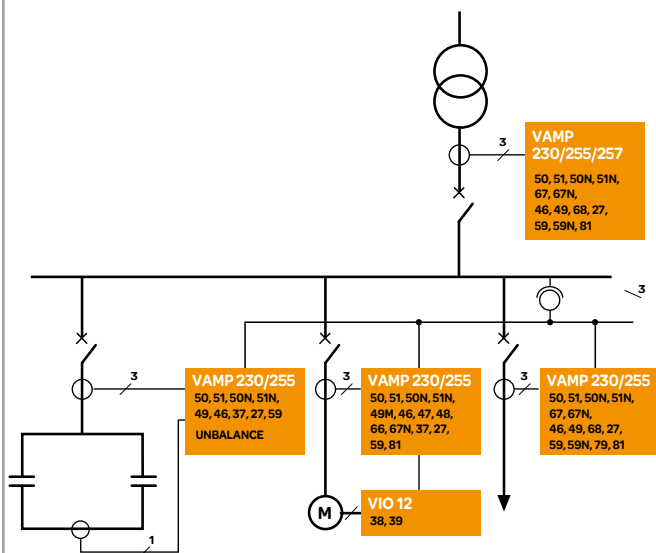

Use of feeder managers for capacitor banks, motors and incoming / outgoing feeders where a three phase voltage, phase and residual current as well as residual voltage connections are required. The RTD module type VIO12 interfaces with the VAMP feeder manager in order to capture temperature measurements from a motor for instance.

VAMP 257

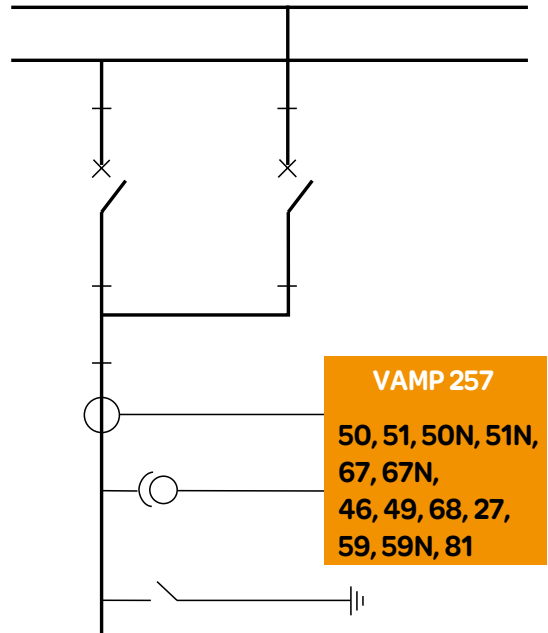

In order to control, collect and display the status information of the primary equipment of the double busbar switchgear, a large number of digital inputs and outputs are required. VAMP 257 feeder manager is designed for double busbar systems and other applications requiring extended I/O amounts.



Connection diagrams

VAMP 230 CONNECTION DIAGRAM

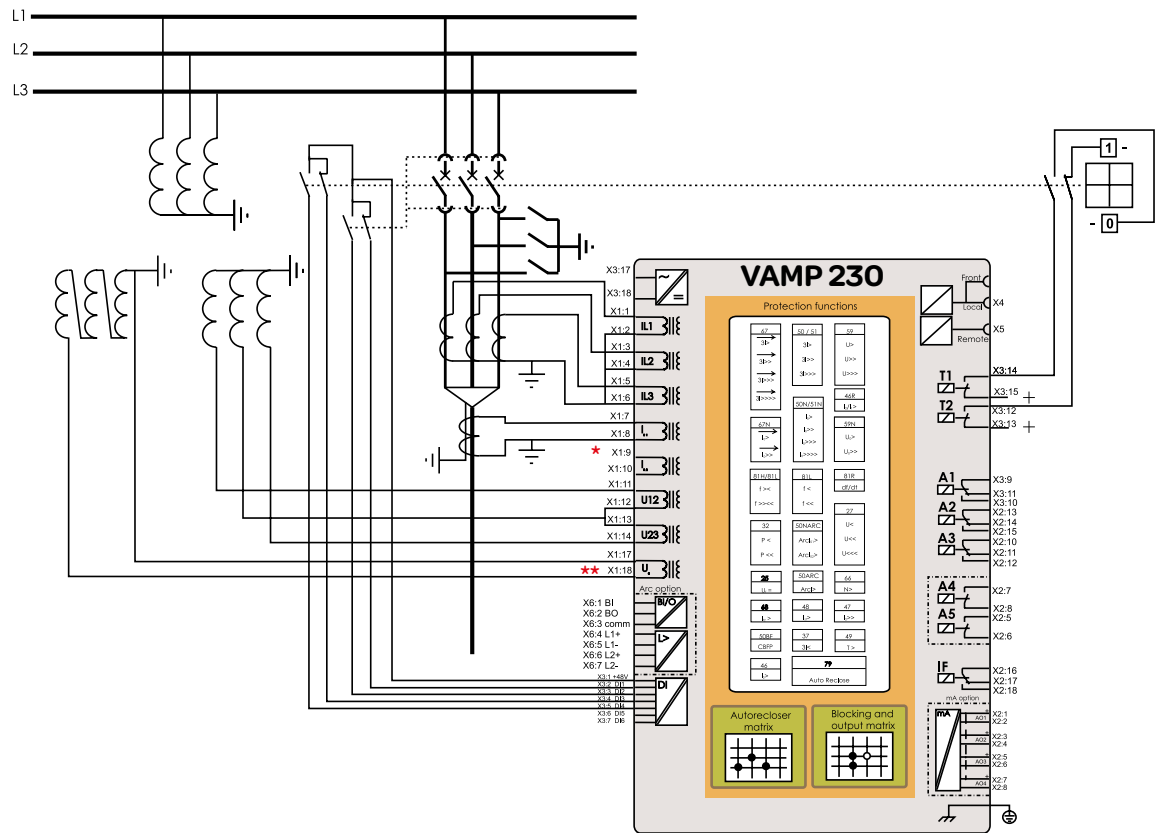

VAMP 255 CONNECTION DIAGRAM

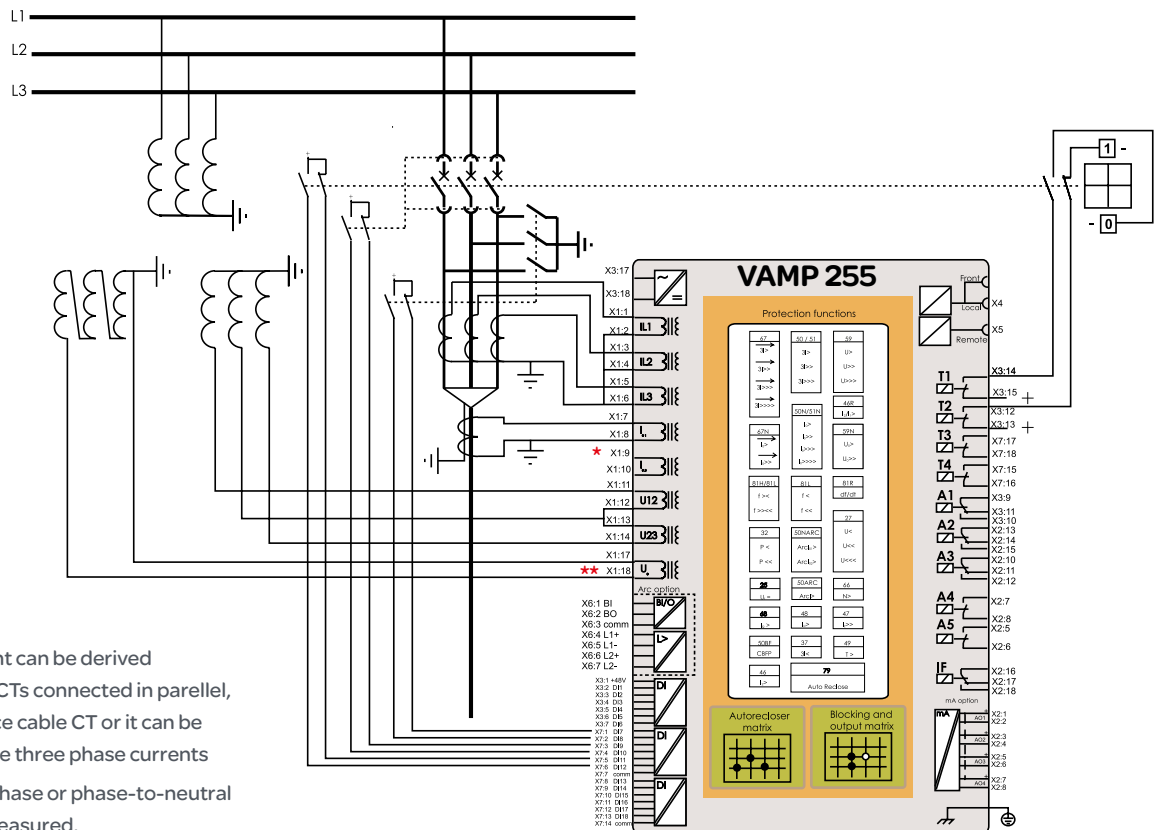

*) The residual current can be derived from three phase CTs connected in parallel, from a core balance cable CT or it can be calculated from the three phase currents

**) Either phase-to-phase or phase-to-neutral voltages can be measured. In the latter case the residual voltage is internally calculated.

VAMP 257
CONNECTION
DIAGRAM

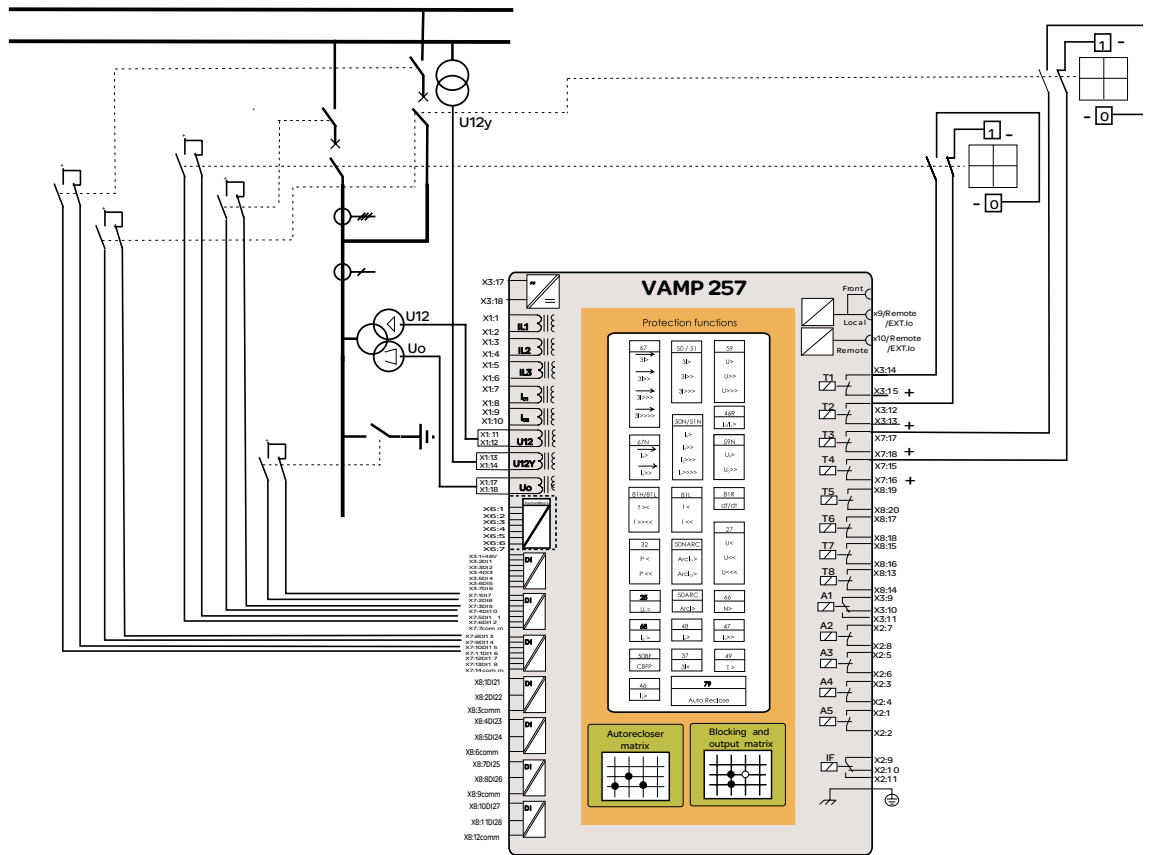

Dimensional drawings

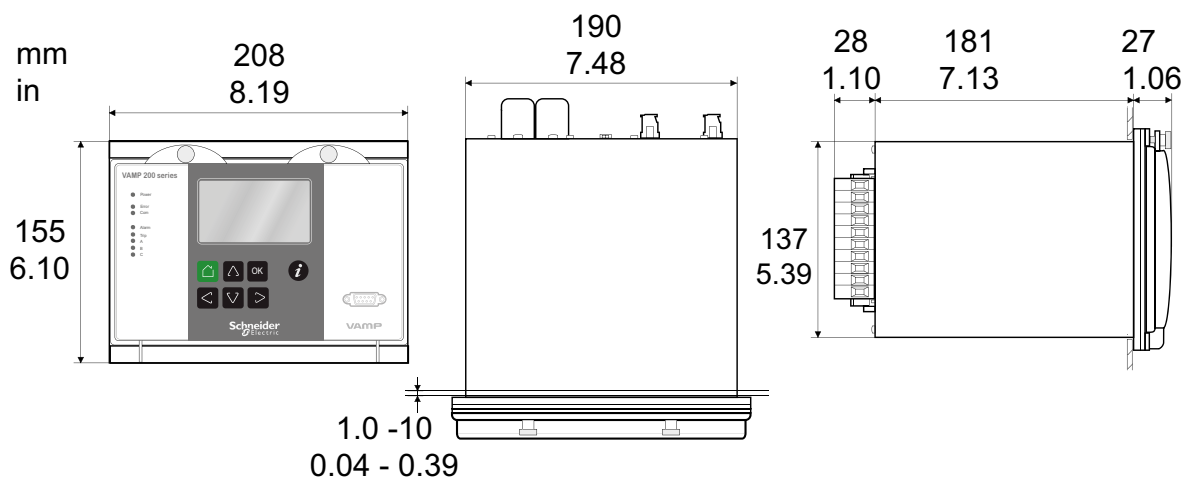

Mounting instructions

PANEL MOUNTING VAMP 200 SERIES

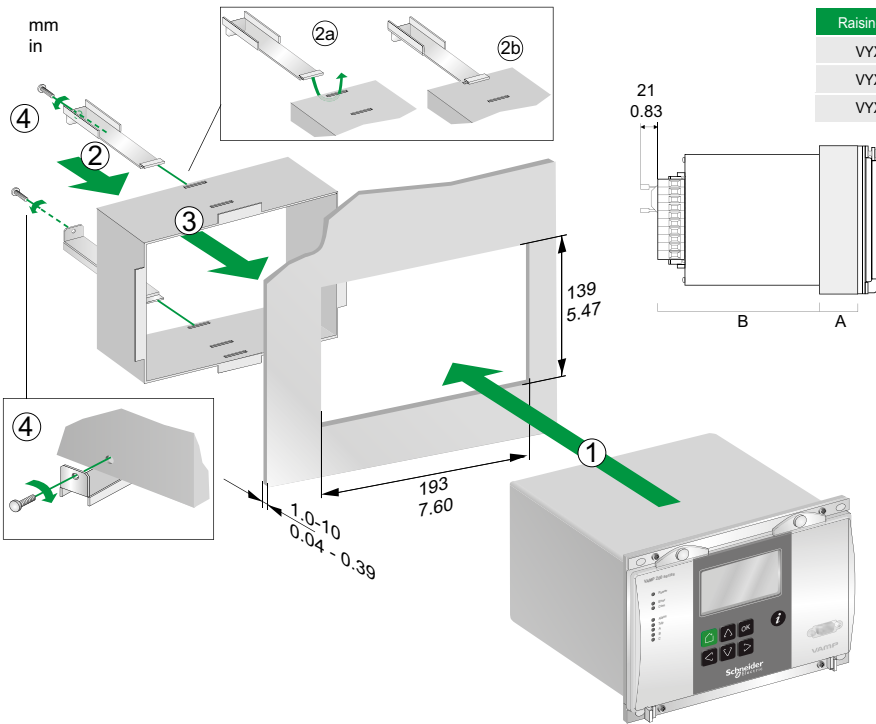

SEMI-FLUSH VAMP 200 SERIES

Raising frame	A	B	Fixing bracket
VYX076	40 mm / 1.57 in	169 mm / 6.65 in	Standard for 200 series
VYX077	60 mm / 2.36 in	149 mm / 5.87 in	Standard for 200 series
VYX233	100 mm / 3.94 in	109 mm / 4.29 in	2 x VYX199 needed

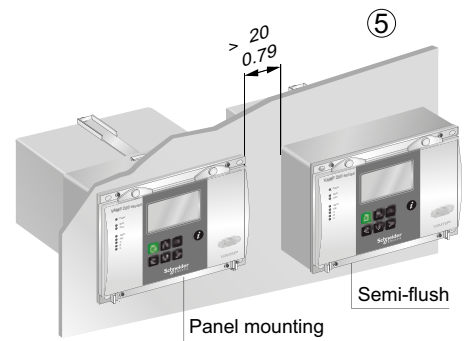

VAMP 200 SERIES WALL ASSEMBLY FRAME TYPE V200WAF

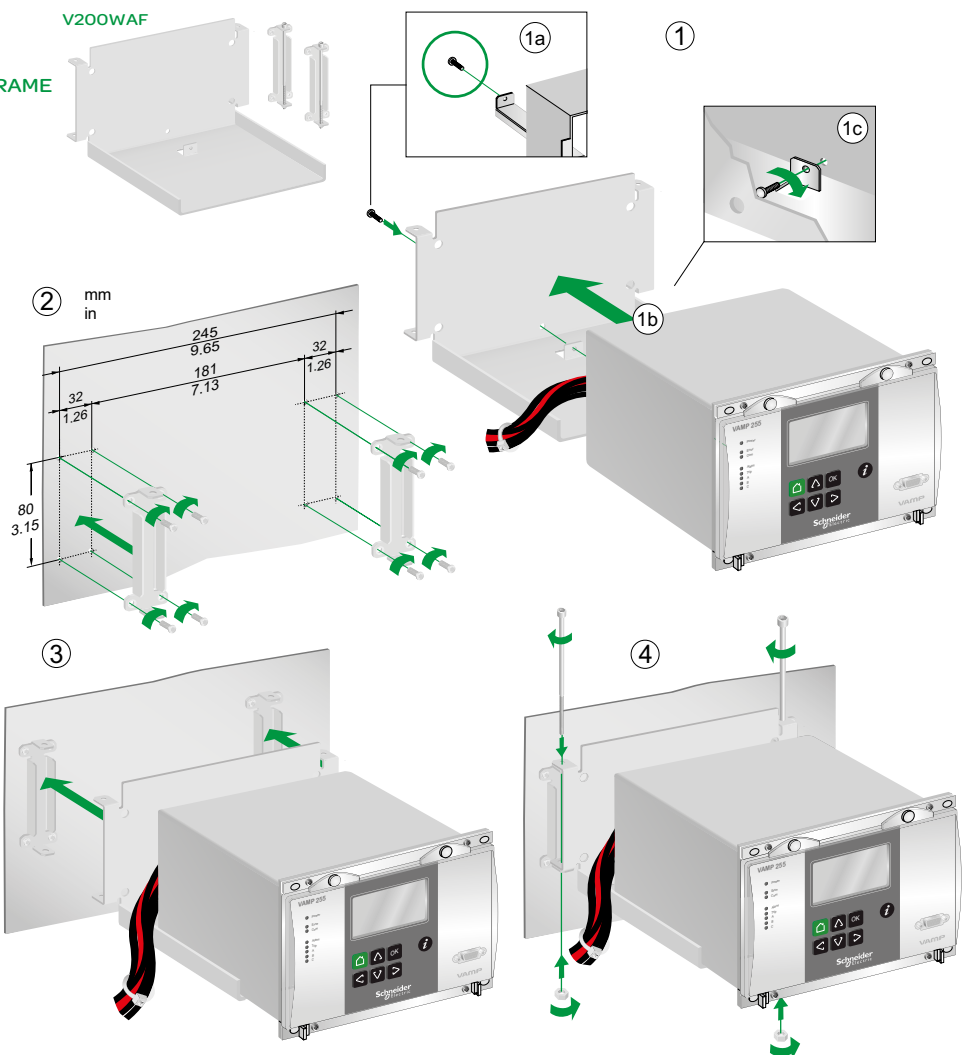

Order Codes

FEEDER AND MOTOR MANAGER VAMP 257



Nominal phase current / activation voltage for DI7-28	
3	= 1 A/5 A / 24 V
5	= 1 A/5 A / 24 V (UL) ⁽¹⁾
6	= 1 A/5 A / 110 V ⁽¹⁾
7	= 1 A/5 A / 220 V ⁽¹⁾
Nominal earth-fault current Io1 & Io2 [A]	
C	= 1 A & 5 A
D	= 0.2 A & 1 A
Additional I/O (X8 terminal)	
6	= None
7	= 8 standard inputs, 4 TCS Hybrid inputs/outputs
8	= 10 outputs
9	= 8 standard inputs and 4 outputs
Supply voltage [V]	
A	= 40.. 265 Vac/dc
B	= 18.. 36 Vdc
C	= 40.. 265Vac/dc + 1 x BI/BO, 2 x Arc sensor
D	= 18.. 36Vdc + 1 x BI/BO, 2 x Arc sensor
E	= 40.. 265Vac/dc + DI19, DI20 + 1 x Arc sensor
F	= 18.. 36Vdc + DI19, DI20 + 1 x Arc sensor
Optional hardware (communication port 1)	
A	= TTL/RS-232 (VCM TTL)
B	= Plastic/Plastic serial fibre interface (VCM FIBRE PP)
C	= None
D	= RS 485 interface (4-wire VCM 485-4)
E	= Glass/Glass serial fibre interface (VCM FIBRE GG)
F	= Rx Plastic/Tx Glass serial fibre interface (VCM FIBRE PG)
G	= Rx Glass/Tx Plastic serial fibre interface (VCM FIBRE GP)
I	= RJ-45 connection (RS-232, VCM 232)
M	= ST 100Mbps ethernet fibre interface inc. IEC 61850
N	= RTD interface (Glass fibre VCM RTD)
Optional hardware (communication port 2)	
A	= None
C	= RJ-45 connection (RS-232 VCM 232)
D	= RS-485 interface (2-wire, VCM 485-2)
L	= RJ-45 10 Mbps ethernet interface ⁽²⁾
M	= RJ-45 10Mbps ethernet interface inc. IEC 61850 ⁽²⁾
N	= RTD interface (Glass fibre, VCM RTD)
Ingress protection rating	
	= IP30 (default)
I	= IP54 (option)

Accessories

Order Code	Explanation	Note
VEA3CGi	External adapter	
VPA3CG	Profibus DP fieldbus option board	
VSE001PP	Fiber optic Module (plastic - plastic)	
VSE002	RS485 Module	
VIO 12 AA	RTD input Module, 12pcs RTD inputs, Optical Tx Communication (24-230 Vac/dc)	
VIO 12 AB	RTD input Module, 12pcs RTD inputs, RS 485 Communication (24-230 Vac/dc)	
VIO 12 AC	RTD and mA output/input module, 12pcs RTD inputs, PTC, mA inputs/outputs	
VIO 12 AD	RS232, RS485 and Optical Tx/Rx Communication (24 Vdc)	
VIO 12 AD	RTD/mA Module, 12pcs RTD inputs, PTC, mA inputs/outputs,	
VIO 12 AD	RS232, RS485 and Optical Tx/Rx Communication (48-230 Vac/dc)	
3PO25	USB to RS232 adapter	
VX003-3	RS232 programming cable (Vampset, VEA 3CGi)	Cable length 3m
VX004-M3	TTL/RS232 converter cable (PLC, VEA 3CGi)	Cable length 3m
VX007-F3	TTL/RS232 converter cable (VPA 3CG)	Cable length 3m
VA 1 DA-6	Arc Sensor	Cable length 6m
VAM 16D	External LED module	Disables rear local communication
VYX076	Projection for 200-series	Height 40mm
VYX077	Projection for 200-series	Height 60mm
VYX233	Projection for 200-series	Height 100mm
V200WAF	V200 wall assembly frame	

Available option-cards possible to be ordered separately:

Order Code	Explanation
VCM 485-4	RS 485 interface (4 wire)
VCM 485-2	RS 485 interface (2 wire)
VCM FIBRE PP	Serial fibre interface (Plastic/Plastic)
VCM FIBRE GG	Serial fibre interface (Glass/Glass)
VCM FIBRE PG	Serial fibre interface (Plastic/Glass)
VCM FIBRE GP	Serial fibre interface (Glass/Plastic)
VCM 232	RS 232 with RJ45 connector
VCM RTD	RTD interface (Glass fibre)
VCM TTL	TTL/RS-232 interface

Note:

⁽¹⁾ DI activation voltage selection applies to DI 7 - DI28 only

⁽²⁾ NOT possible to order in combination with the following optional communication module 1: (M) ST 100Mbps ethernet fibre interface with IEC 61850

FEEDER MANAGERS VAMP 255 / 230

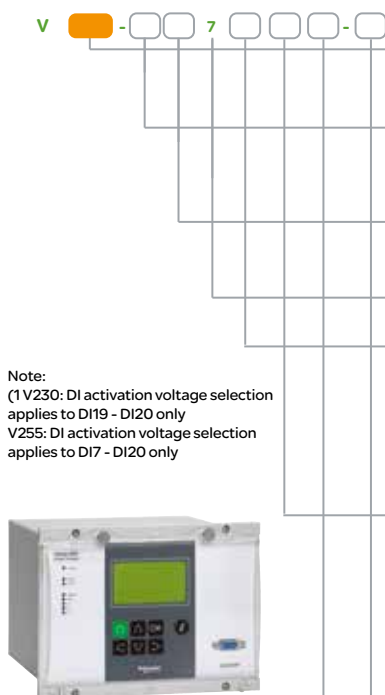

Manager type
255 = VAMP 255 feeder and motor manager
230 = VAMP 230 feeder and motor manager

Nominal phase current / activation voltage
3 = 1 A / 5 A / 24 V
6 = 1 A / 5 A / 110 V [†]
7 = 1 A / 5 A / 220 V [†]

Nominal earth-fault current Io1 / Io2 [A]
C = 1 A / 5 A
D = 0.2 A / 1 A

Frequency [Hz]
7 = Standard relay

Supply voltage [V]
A = 40..265 V ac/dc
B = 18..36 V dc
C = 40..265 V ac/dc + 1x BI/BO, 2x Arc sensor
D = 18..36 V dc + 1x BI/BO, 2x Arc sensor
E = 40..265 V ac/dc + DI19, DI20 + 1x Arc sensor
F = 18..36 V dc + DI19, DI20 + 1x Arc sensor

Communication interface
A = None
B = Plastic/Plastic serial fibre interface
C = Profibus Interface
D = RS 485 interface (4-wire)
E = Glass/Glass serial fibre interface
F = Rx Plastic/Tx Glass serial fibre interface
G = Rx Glass/Tx Plastic serial fibre interface
H = RJ-45 10Mbps ethernet interface
M = RJ-45 10Mbps ethernet with IEC 61850
O = LC 100 Mbps ethernet fibre interface with IEC 61850
P = RJ-45 100Mbps ether net interface with IEC 61850
R = 2x LC 100 Mbps ether net fibre interface with IEC 61850
S = 2x RJ-45 100 Mbps ether net interface with IEC 61850

Analog Outputs & firmware
E = None, standard firmware
F = 4 pcs, standard firmware

Analog Outputs & firmware
I = IP30 (default)
I = IP54 (option)

Note:
 (1 V230: DI activation voltage selection applies to DI19 - DI20 only
 V255: DI activation voltage selection applies to DI7 - DI20 only)

Accessories

Order code	Descriptionj	Note
VPA3CGi	External ethernet	
VPA3CG	Profibus DP fieldbus option board	
VSE001PP	Fiber optic module (plastic - plastic)	
VSE002	RS485 Module	
VSE003	Local port RS485 Interface Module, Ext I/O interface	
VSE009	DeviceNet module	
VIO 12 AB	RTD input Module, 12pcs RTD inputs, RS 485 Communication (24-230 Vac/dc)	
VIO 12 AC	RTD and mA output/input module, 12 pcs RTD inputs, PTC, mA inputs/outputs	
	RS232, RS485 and Optical Tx/Rx Communication (24 Vdc)	
VIO 12 AD	RTD/mA Module, 12pcs RTD inputs, PTC, mA inputs/outputs,	
	RS232, RS485 and Optical Tx/Rx Communication (48-230 Vac/dc)	
VX003-3	RS232 programming cable (Vampset, VEA 3CGi)	Cable length 3m
VX004-M3	TTL/RS232 converter cable (PLC, VEA 3CGi)	Cable length 3m
VX007-F3	TTL/RS232 converter cable (VPA 3CG)	Cable length 3m
VA 1 DA-6	Arc Sensor	Cable length 6m
VAM 16D	External LED module	Disables rear local communication
VYX076	Raising Frame for 200-series	Height 40mm
VYX077	Raising Frame for 200-series	Height 60mm
VYX233	Raising Frame for 200-series	Height 100mm
V200WAF	V200 wall assembly frame	

Technical data

Measuring circuitry

Rated phase current	5 A (configurable for CT secondaries 1 – 10 A)
Current measuring range	0..250 A
Thermal withstand	20 A (continuously)
	100 A (for 10 s), 500 A (for 1 s)
Burden	< 0.2 VA
Rated residual current (optional)	5A (configurable for CT secondaries 1 – 10 A)
Current measuring range	0..50 A
Thermal withstand	20 A (continuously)
	100 A (for 10 s), 500 A (for 1 s)
Burden	< 0.2 VA
Rated residual current	1A (configurable for CT secondaries 0.1 – 10.0 A)
Current measuring range	0..10 A
Thermal withstand	4 A (continuously)
	20 A (for 10 s), 100 A (for 1 s)
Burden	< 0.1 VA
Rated residual current (optional)	0.2 A (configurable for CT secondaries 0.1-10.0 A)
Current measuring range	0..2 A
Thermal withstand	0.8 A (continuously)
	4 A (for 10 s), 20 A (for 1 s)
Burden	< 0.1 VA

Rated voltage Un	100 V (configurable for VT secondaries 50-120 V)
Voltage measuring range	0 – 160 V (100 V/110 V)
Continuous voltage withstand	250 V
Burden	< 0.5V A
Rated frequency fn	45 – 65 Hz
Frequency measuring range	6 – 75 Hz
Terminal block	Solid or stranded wire
Maximum wire dimension	4 mm² (10-12 AWG)

Auxiliary voltage	Type A (standard)	Type B (option)
Rated voltage U_{aux}	40 - 265 V ac/dc	18...36 V dc
	110/120/220/240 V	24 V dc
	48/60/110/125/220 V dc	
Power consumption	< 15 W (normal conditions)	
	< 25 W (output relays activated)	
Max. permitted interruption time	< 50 ms (110 V dc)	
Terminal block:	Phoenix MVSTBW or equivalent	
Maximum wire dimension	2.5 mm ² (13-14 AWG) :	

Package

Dimensions (W x H x D)	215 x 160 x 275 mm
Weight (Terminal, Package and Manual)	5.2 kg

Disturbance tests

Emission (EN 50081-1)	
Conducted (EN 55022B)	0.15 - 30 MHz
Emitted (CISPR 11)	30 - 1 000 MHz
Immunity (EN 50082-2)	
Static discharge (ESD) EN 61000-4-2, class III	6 kV contact discharge
	8 kV air discharge
Fast transients (EFT) EN 61000-4-4, class III	2 kV, 5/50 ns, 5 kHz, +/-
Surge EN, 61000-4-5, class III	1.2/50 μ s, common mode
	1 kV, 1.2/50 μ s, differential mode
Conducted HF field, EN 61000-4-6	0.15 - 80 MHz, 10 V
Emitted HF field, EN 61000-4-3	80 - 1000 MHz, 10 V/m
GSM test, ENV 50204	900 MHz, 10 V/m, pulse modulated

Test-voltages

Insulation test voltage (IEC 60255-5)	2 kV, 50 Hz, 1 min
Surge voltage (IEC 60255-5)	5 kV, 1.2/50 μ s, 0.5 J

Mechanical tests

Vibration (IEC 60255-21-1)	
10...60 Hz, amplitude 10.035 mm	
60...150 Hz, acceleration 0.5g	
sweep rate 1 octave/min	
20 periods in X-, Y- and Z axis direction	
Shock (IEC 60255-21-1)	
half sine, acceleration	5 g
duration	11 ms
3 shocks in X-, Y- and Z axis direction	

Environmental conditions

Operating temperature	-10...+55 ° C
Degree of protection (IEC 60529)	IP20
Transport and storage temperature	-40 to +70° C
Relative humidity	< 75% (1 year, average value), < 90% (30 days per year, no condensation permitted)



Tests performed by thrid party accredited laboratory SGS.



Functionality verified by KEMA.



DEVICE TRACK RECORD

- Schneider Electric's VAMP Range specialises in protection protection relays, arc flash protection and measuring and monitoring units for power systems.
- VAMP's medium-voltage and sub-transmission protection relays are used in numerous applications, from overhead line feeders and substations to power plants and industrial power system. Their unique integrated arc flash fault protection functionality enhances the safety of both people and property and has made VAMP a leading brand in arc flash protection worldwide. All VAMP products meet the latest international standards and regulations.
- Our success is based on competitive standard products, constant development by our designers possessing experience from three protection relay generations, our long-term partnerships, flexibility and 24 h care of the customers.

Schneider Electric Industries SAS

35, rue Joseph Monier
CS 30323
F - 92506 Rueil Malmaison Cedex (France)
Tel.: +33 (0) 1 41 29 70 00
RCS Nanterre 954 503 439
Capital social 896 313 776 €
www.schneider-electric.com

As standards, specifications and designs change from time to time, please ask for confirmation of the information given in this publication.

Design: Schneider Electric Industries SAS - Sonovision
Photos: Schneider Electric Industries SAS

