

# Easergy P3M30 and P3M32

Motor protection relay

Publication version: P3M/en M/B004

User Manual



Trace back information:  
Workspace Main version a184  
Checked in 2018-12-21  
Skribenta version 5.2.030

---

## Table of Contents

<b>1</b>	<b>Important information</b>	<b>9</b>
1.1	Hazard categories and special symbols	9
1.2	Legal notice	11
1.3	Purpose	12
1.4	EU directive compliance	13
1.5	Abbreviations and terms	14
<b>2</b>	<b>Introduction</b>	<b>17</b>
2.1	Product overview	17
2.2	Product selection guide	17
2.3	Presentation	23
2.4	Operating levels	24
2.5	Front panel	26
2.5.1	Push-buttons	27
2.5.2	LED indicators	28
2.5.3	Controlling the alarm screen	29
2.5.4	Accessing operating levels	29
2.5.5	Adjusting the LCD contrast	30
2.5.6	Testing the LEDs and LCD screen	30
2.5.7	Controlling an object with selective control	30
2.5.8	Controlling an object with direct control	31
2.5.9	Menus	31
2.6	Easergy Pro setting and configuration tool	33
<b>3</b>	<b>Mechanical structure</b>	<b>35</b>
3.1	Modularity	35
3.2	Slot info and order code	37
<b>4</b>	<b>Measurement functions</b>	<b>38</b>
4.1	Primary, secondary and per unit scaling	40
4.1.1	Frequency adaptation mode	43
4.1.2	Current scaling	44
4.1.3	Voltage scaling for analogue module E, F	47
4.2	Measurements for protection functions	50
4.3	Measurements for arc protection function	51
4.4	RMS values	52
4.5	Harmonics and total harmonic distortion (THD)	52
4.6	Demand values	53
4.7	Minimum and maximum values	54
4.8	Maximum values of the last 31 days and 12 months	55
4.9	Power and current direction	57
4.10	Symmetric components	58

<b>5</b>	<b>Control functions .....</b>	<b>59</b>
5.1	Digital outputs .....	59
5.2	Digital inputs .....	62
5.3	Virtual inputs and outputs .....	66
5.4	Matrix .....	69
5.4.1	Output matrix .....	70
5.4.2	Blocking matrix .....	71
5.4.3	LED matrix .....	72
5.4.4	Object block matrix .....	74
5.5	Releasing latches .....	75
5.5.1	Releasing latches using Easergy Pro .....	75
5.5.2	Releasing latches using buttons and local panel display .....	75
5.5.3	Releasing latches using F1 or F2 buttons .....	75
5.6	Controllable objects .....	77
5.6.1	Object control with digital inputs .....	78
5.6.2	Local or remote selection .....	79
5.6.3	Object control with I and O buttons .....	79
5.6.4	Object control with F1 and F2 .....	80
5.7	Logic functions .....	82
5.8	Local panel .....	88
5.8.1	Mimic display .....	88
5.8.2	Local panel configuration .....	90
<b>6</b>	<b>Protection functions .....</b>	<b>93</b>
6.1	Maximum number of protection stages in one application .....	93
6.2	General features of protection stages .....	93
6.3	Dependent operate time .....	101
6.3.1	Standard dependent delays using IEC, IEEE, IEEE2 and RI curves .....	103
6.3.2	Free parameterization using IEC, IEEE and IEEE2 curves .....	114
6.3.3	Programmable dependent time curves .....	115
6.4	Synchrocheck (ANSI 25) .....	116
6.5	Undervoltage (ANSI 27) .....	120
6.6	Directional power (ANSI 32) .....	124
6.7	Phase undercurrent (ANSI 37) .....	125
6.8	Negative sequence overcurrent (ANSI 46) .....	126
6.9	Incorrect phase sequence (ANSI 47) .....	128
6.10	Motor start-up supervision (ANSI 48) .....	129
6.11	Thermal overload (ANSI 49M) .....	133
6.12	Phase overcurrent (ANSI 50/51) .....	137
6.13	Breaker failure 1 (ANSI 50BF) .....	141
6.14	Breaker failure 2 (ANSI 50BF) .....	143
6.15	Switch-onto-fault (ANSI 50HS) .....	149
6.16	Earth fault overcurrent (ANSI 50N/51N) .....	151
6.16.1	Earth fault faulty phase detection algorithm .....	153



---

6.17	Capacitor bank unbalance (ANSI 51C)	155
6.18	Locked rotor (ANSI 51LR)	162
6.19	Overvoltage (ANSI 59)	164
6.20	Neutral voltage displacement (ANSI 59N)	167
6.21	Motor restart inhibition (ANSI 66)	169
6.22	Directional phase overcurrent (ANSI 67)	171
6.23	Directional earth fault overcurrent (ANSI 67N)	176
6.23.1	Earth fault faulty phase detection algorithm	181
6.24	Magnetising inrush detection (ANSI 68F2)	183
6.25	Fifth harmonic detection (ANSI 68H5)	184
6.26	Overfrequency and underfrequency (ANSI 81)	185
6.27	Rate of change of frequency (ANSI 81R)	187
6.28	Lockout (ANSI 86)	191
6.29	Differential overcurrent protection (ANSI 87M)	192
6.30	Arc flash protection (AFD)	201
6.30.1	Arc flash protection, general principle	201
6.30.2	Arc flash protection menus	201
6.30.3	Example of arc flash protection configuration	206
6.30.4	Arc fault protection (optional)	212
6.31	Programmable stages (ANSI 99)	213
<b>7</b>	<b>Supporting functions</b>	<b>216</b>
7.1	Event log	216
7.2	Disturbance recording	218
7.3	Cold load start and magnetising inrush	223
7.4	System clock and synchronization	225
7.5	Voltage sags and swells	231
7.6	Voltage interruptions	234
7.7	Current transformer supervision (ANSI 60)	236
7.8	Voltage transformer supervision (ANSI 60FL)	238
7.9	Circuit breaker condition monitoring	240
7.10	Circuit breaker condition monitoring 1 and 2	245
7.11	Energy pulse outputs	248
7.12	Running hour counter	251
7.13	Timers	252
7.14	Combined overcurrent status	254
7.15	Trip circuit supervision (ANSI 74)	257
7.15.1	Trip circuit supervision with one digital input	257
7.15.2	Trip circuit supervision with two digital inputs	263
<b>8</b>	<b>Communication and protocols</b>	<b>267</b>
8.1	Communication ports	267
8.1.1	Ethernet port	269
8.2	Communication protocols	270
8.2.1	Modbus RTU and Modbus TCP	270
8.2.2	Profibus DP	270
8.2.3	SPA-bus	271
8.2.4	IEC 60870-5-103 (IEC-103)	272

8.2.5	DNP 3.0 .....	273
8.2.6	IEC 60870-5-101 (IEC-101) .....	273
8.2.7	IEC 61850 .....	274
8.2.8	EtherNet/IP .....	274
8.2.9	HTTP server – Webset .....	275
<b>9</b>	<b>Applications and configuration examples .....</b>	<b>276</b>
9.1	Industrial motor protection .....	277
9.2	Using CSH120 and CSH200 with core balance CTs .....	278
<b>10</b>	<b>Installation .....</b>	<b>280</b>
10.1	Checking the consignment .....	280
10.2	Product identification .....	280
10.3	Storage .....	282
10.4	Mounting .....	283
10.5	Connections .....	288
10.5.1	Supply voltage cards .....	288
10.5.2	Analogue measurement cards .....	291
10.5.2.1	"E = 3L(5/1A) + 4U + 2I <sub>0</sub> (5/1A+1/0.2A)" .....	292
10.5.2.2	"F = 3L(1A) + 4U + 2I <sub>0</sub> (5/1A+1/0.2A)" .....	293
10.5.2.3	"T = 3 x I (5/1A) + I <sub>0</sub> (5/1A)" .....	294
10.5.3	I/O cards .....	295
10.5.3.1	I/O card "G = 6DI+4DO" .....	295
10.5.3.2	I/O card "I = 10DI" .....	296
10.5.3.3	I/O card "H = 6DI + 4DO (NC)" .....	297
10.5.4	I/O option card "D= 4Arc" .....	298
10.5.5	Communication cards .....	298
10.5.5.1	COM 3–COM 4 ports .....	301
10.5.6	Local port (Front panel) .....	306
10.5.7	Connection data .....	307
10.5.8	External option modules .....	314
10.5.8.1	VSE-001 fiber optic interface module .....	314
10.5.8.2	VSE-002 RS-485 interface module .....	316
10.5.8.3	VSE-009 DeviceNet interface module .....	318
10.5.8.4	VPA-3CG profibus interface module .....	319
10.5.8.5	VIO 12A RTD and analog input / output modules .....	320
10.5.9	Block diagrams .....	321
10.5.10	Connection examples .....	323
10.6	Voltage measurement modes .....	325
10.6.1	Multiple channel voltage measurement .....	325
10.7	CSH120 and CSH200 Core balance CTs .....	335
<b>11</b>	<b>Test and environmental conditions .....</b>	<b>338</b>

<b>12 Maintenance .....</b>	<b>341</b>
12.1 Preventative maintenance .....	342
12.2 Periodical testing .....	342
12.3 Hardware cleaning .....	342
12.4 Arc sensor condition and positioning check .....	342
12.5 System status messages .....	342
12.6 Spare parts .....	343
12.7 Self-supervision .....	343
12.7.1 Diagnostics .....	346
<b>13 Order code .....</b>	<b>348</b>
<b>14 Firmware revision .....</b>	<b>352</b>



# 1 Important information

## 1.1 Hazard categories and special symbols

### Important Information

Read these instructions carefully and look at the equipment to become familiar with the device before trying to install, operate, service or maintain it. The following special messages may appear throughout this bulletin or on the equipment to warn of potential hazards or to call attention to information that clarifies or simplifies a procedure.



The addition of either symbol to a “Danger” or “Warning” safety label indicates that an electrical hazard exists which will result in personal injury if the instructions are not followed.



This is the safety alert symbol. It is used to alert you to potential personal injury hazards. Obey all safety messages that follow this symbol to avoid possible injury or death.

### **⚠ DANGER**

**DANGER** indicates an imminently hazardous situation which, if not avoided, **will result in** death or serious injury.

### **⚠ WARNING**

**WARNING** indicates a potentially hazardous situation which, if not avoided, **can result in** death or serious injury.

### **⚠ CAUTION**

**CAUTION** indicates a potentially hazardous situation which, if not avoided, **can result in** minor or moderate injury or equipment damage.

### **NOTICE**

**NOTICE** is used to address practices not related to physical injury or equipment damage.

### Protective grounding

The user is responsible for compliance with all the existing international and national electrical codes concerning protective grounding of any device.

### Please Note

Use the device's password protection feature to prevent untrained persons from interacting with this device.

## **⚠ DANGER**

### **HAZARD OF ELECTRIC SHOCK, EXPLOSION, OR ARC FLASH**

Electrical equipment should be installed, operated, serviced, and maintained only by trained and qualified personnel. No responsibility is assumed by Schneider Electric for any consequences arising out of the use of this material.

**Failure to follow this instruction will result in death or serious injury.**

---

## 1.2 Legal notice

### Copyright

2018 Schneider Electric. All rights reserved.

### Disclaimer

No responsibility is assumed by Schneider Electric for any consequences arising out of the use of this document. This document is not intended as an instruction manual for untrained persons. This document gives instructions on device installation, commissioning and operation. However, the manual cannot cover all conceivable circumstances or include detailed information on all topics. In the event of questions or specific problems, do not take any action without proper authorization. Contact Schneider Electric and request the necessary information.

### Contact information

35 rue Joseph Monier  
92500 Rueil-Malmaison  
FRANCE  
Phone: +33 (0) 1 41 29 70 00  
Fax: +33 (0) 1 41 29 71 00  
[www.schneider-electric.com](http://www.schneider-electric.com)

## 1.3 Purpose

This document contains instructions on the installation, commissioning and operation of Easergy P3M30 and P3M32.

This document is intended for persons who are experts on electrical power engineering, and it covers the relay models as described by the order code in Chapter 13 Order code.

### Related documents

Document	Identification*)
P3 Advanced Quick Start	P3x3x/EN QS/xxxx
Easergy Pro Setting and Configuration Tool User Manual	P3eSetup/EN M/xxxx
RTD and mA Output/Input Modules User Manual	P3VIO12A/EN M/A001
Profibus Interface Module User Manual	P3VPA3CG/EN M/A001
IEC 61850 interface in Easergy P3 relays configuration instruction	P3APS17001EN
Rapid Spanning Tree Protocol (RSTP)	P3APS17002EN
EtherNet/IP configuration instructions	P3APS17003EN
Parallel Redundancy Protocol for Easergy P3 relays with dual-port 100 Mbps Ethernet interface	P3APS17004EN
Communication parameter protocol mappings	P3TDS17005EN
Easergy P3 protection functions' parameters and recorded values	P3TDS17006EN
DeviceNet and EtherNet/IP data model	P3APS17008EN
IEC103 Interoperability List	P3TDS17009EN
DNP 3.0 Device Profile Document	P3TDS17010EN
P3 Advanced Series facia label instruction	P3TDS17012EN
Principles of numerical protection techniques	P3INS17019EN

\*) *xxxx = revision number*

Download the latest software from [easergy.schneider-electric.com](http://easergy.schneider-electric.com).



## 1.4 EU directive compliance

### EMC compliance

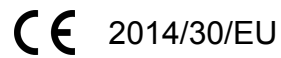

Compliance with the European Commission's EMC Directive. Product Specific Standard was used to establish conformity:

- EN 60255-26 2013

### Product safety

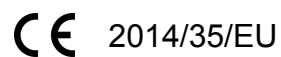

Compliance with the European Commission's Low Voltage Directive. Product Specific Safety Standard was used to establish conformity:

- EN 60255-27 2014

# 1.5 Abbreviations and terms

AFD	Arc flash detection
ANSI	American National Standards Institute. A standardization organisation.
bps	Bits per second
CB	Circuit breaker
CBFP	Circuit breaker failure protection
CLPU	Cold load pickup
CM	Common mode
Controlling output	Heavy duty output rated for the circuit breaker controlling
CPU	Central processing unit
$\cos\phi$	Active power divided by apparent power = P/S. (See power factor PF). Negative sign indicates reverse power.
CT	Current transformer
CT <sub>PR1</sub>	Nominal primary value of current transformer
CT <sub>SEC</sub>	Nominal secondary value of current transformer
Dead band	See hysteresis.
DI	Digital input
Digital output	Refers to relay's output contacts.
DM	Differential mode
DO	Digital output
Document file	Stores information about the relay settings, events and fault logs.
DSM	Distribution management system
DSR	Data set ready. An RS232 signal. Input in front panel port of Easergy P3 relays to disable rear panel local port.
DST	Daylight saving time. Adjusting the official local time forward by one hour for summer time.
DT	Definite time
DTR	Data terminal ready. An RS232 signal. Output and always true (+8 Vdc) in front panel port of Easergy P3 relays.
Easergy P3 Standard	Refers to P3U10, P3U20 and P3U30 relays
Easergy P3 Advanced	Refers to P3F30, P3L30, P3M30/32, P3GH30/32 and P3T32 relays
eSetup Easergy Pro	Setting and configuration tool for Easergy P3 protection relays, later called Easergy Pro
GOOSE	Generic object-oriented substation event: a specific definition of a type of generic substation event, for peer-peer communication.
Hysteresis	I.e. dead band. Used to avoid oscillation when comparing two near by values.
IDMT	Inverse definite minimum time
I <sub>MODE</sub>	Nominal current of the selected mode. In feeder mode, I <sub>MODE</sub> = V <sub>T</sub> PRIMARY. In motor mode, I <sub>MODE</sub> = I <sub>MOT</sub> .
I <sub>MOT</sub>	Nominal current of the protected motor
I <sub>N</sub>	Nominal current. Rating of CT primary or secondary.
I <sub>SET</sub>	Pickup setting value I>
I <sub>0N</sub>	Nominal current of I <sub>0</sub> input in general

IEC	International Electrotechnical Commission. An international standardization organisation.
IEC-101	Abbreviation for communication protocol defined in standard IEC 60870-5-101
IEC-103	Abbreviation for communication protocol defined in standard IEC 60870-5-103
IEEE	Institute of Electrical and Electronics Engineers
IRIG-B	Inter-Range Instrumentation Group time code B: standard for time transfer
LAN	Local area network. Ethernet-based network for computers and devices.
Latching	Digital outputs and indication LEDs can be latched, which means that they are not released when the control signal is releasing. Releasing of latched devices is done with a separate action.
LCD	Liquid crystal display
LED	Light-emitting diode
NTP	Network Time Protocol for LAN and WWW
OVF	Indication of the event overflow
P	Active power. Unit = [W]
PF	Power factor. The absolute value is equal to $\cos\phi$ , but the sign is 'IND' for inductive i.e. lagging current and 'CAP' for capacitive i.e. leading current.
PLC	Programmable logic controller
$P_M$	Nominal power of the prime mover. (Used by reverse/under power protection.)
pu	Per unit. Depending of the context the per unit refers to any nominal value. For example for overcurrent setting $1 \text{ pu} = 1 \times I_{MOT}$ .
P3M30	Refers P3M30 motor protection relay
Q	Reactive power. Unit = [var]
RELxxxxx	Short order code
RH	Relative humidity
RMS	Root mean square
RS232 or RS485 (EIA-232 or EIA-485)	Standard defining the electrical characteristics of a serial communication interface
RTU	Remote terminal unit
S	Apparent power. Unit = [VA]
SCADA	Supervisory control and data acquisition
SF	Alarm duty watchdog output is energized when the auxiliary power supply is on and the product status is operative. This output is referenced as "service status output" in the setting tool.
Signaling output	Alarm duty output rated, not suitable for direct circuit breaker controlling
SNTP	Simple Network Time Protocol for LAN and WWW
SOTF	Switch on to fault
SPST	Single pole single throw
SPDT	Single pole double throw
TCS	Trip circuit supervision
THD	Total harmonic distortion
$U_{0SEC}$	Voltage at input $U_c$ at zero ohm ground fault. (Used in voltage measurement mode "2LL+ $U_0$ ")
$U_A$	Voltage input for $U_{12}$ or $U_{L1}$ depending of the voltage measurement mode
$U_B$	Voltage input for $U_{23}$ or $U_{L2}$ depending of the voltage measurement mode

---

U <sub>C</sub>	Voltage input for U <sub>31</sub> or U <sub>0</sub> depending of the voltage measurement mode
U <sub>N</sub>	Nominal voltage. Rating of VT primary or secondary
UMI	User Machine Interface
USB	Universal serial bus
UTC	Coordinated Universal Time (used to be called GMT = Greenwich Mean Time)
Webset	http configuration interface
VI	Virtual input
VO	Virtual output
VT	Voltage transformer
VT <sub>PRI</sub>	Nominal primary value of voltage transformer
VT <sub>SEC</sub>	Nominal secondary value of voltage transformer

## 2 Introduction

### 2.1 Product overview

The relay has a modular design and it can be optimized to almost all type of motor applications in low and medium voltage distribution systems.

#### **Main characteristic and options**

- The relay has all the necessary motor and feeder protection for industrial power distribution networks.
- The relay has an optional interface for connecting 4 arc flash point sensors.
- Two alternative display options
  - 128 x 128 LCD matrix
  - 128 x 128 LCD matrix detachable
- Power quality measurements and disturbance recorder enable capture of quick network phenomena
- Wide range of communication protocols i.e. IEC61850, Profibus DP to Modbus TCP



#### **The following options depend on the order code:**





- multiple power supply options
- earth fault overcurrent input sensitivity
- amount of digital inputs
- amount of trip contacts
- integrated arc-options (point sensors)
- various possibilities with communication interfaces

The relay has good protection against harsh environments. The front panel protection level is IP54.

### 2.2 Product selection guide

The selection guide by application suggests Easergy P3 types suitable for your protection requirements, based on your application characteristics. The most typical applications are presented along with the associated Easergy P3 type.

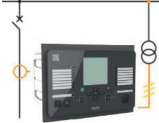
		Easergy P3 Standard			Easergy P3 Advanced						
											
Voltage		-	-	P3U30 with directional o/c with voltage protection				-			
Feeder						P3F30 w. directional P3L30 w. line diff. & distance				-	
Transformer		P3U10	P3U20			-				P3T32 with differential	
Motor						P3M30				P3M32 with differential	
Generator						P3G30				P3G32 with differential	
Measuring inputs	Phase Current	1/5A CT (x3)			1/5A CT (x3)		1/5A CT (x6)				
	Residual Current	1/5A CT or 0.2/1A CT			5/1A+1/0.2A		5/1A+1/0.2A + 5/1A CT				
	Voltage	VT (x1)		VT (x4)	VT (x4)		VT (x4)				
Arc-flash sensor input		-			0 to 4 point sensor		0 to 4 point sensor				
Digital	Input	2	8/10	16	6 to 36		6 to 16				
	Output	5 + SF	5/8 + SF	8 + SF	10 to 21 + SF		10 to 13 + SF				
Analogue	Input	-	0 or 4 <sup>(4)</sup>		0 or 4 <sup>(4)</sup>						
	Output	-	0 or 4 <sup>(4)</sup>		0 or 4 <sup>(4)</sup>						
Temperature sensor input		-	0 or 8 or 12 <sup>(4)</sup>		0 or 8 or 12 <sup>(4)</sup>						
Front port		USB			USB						
Nominal power supply		24 V dc or 48-230 V ac/dc			24-48 V dc or 110-240 V ac/dc						
Ambient temperature, in service		-40 to 60°C (-40 to 140°F)			-40 to 60°C (-40 to 140°F)						

		Easergy P3 Standard		Easergy P3 Advanced	
					
<b>Communication</b>					
Rear ports	RS-232	-	■	■	■
	IRIG/B		■	■	■
	RS-485	-	■	Using external I/O module	Using external I/O module
	ETHERNET	-	■	■	■
Protocols	IEC61850 Ed1 & Ed2	-	■	■	■
	IEC 60870-5-101	-	■	■	■
	IEC 60870-5-103	-	■	■	■
	DNP3 Over Ethernet	-	■	■	■
	Modbus serial	-	■	■	■
	Modbus over Ethernet	-	■	■	■
	EtherNet/IP	-	■	■	■
	DeviceNet	-	■	■	■
	Profibus DP	-	■	■	■
	SPAbus	-	■	■	■
Redundancy protocols	RSTP	-	■	■	■
	PRP	-	■	■	■
<b>Others</b>					
Control		1 object Mimic	6 objects + 2 monitored objects Mimic	6 objects + 2 monitored objects Mimic	
Logic	Matrix		■	■	
	Logic Equations		■	■	
Cyber security			Password	Password	
Withdrawability (Pluggable connector)			■	-	
Remote UMI			-	■	

**NOTE:** The numbers in the following tables represent the amount of stages available for each Easergy P3 type.

Protection functions	ANSI code	Feeder P3U10/20	Feeder P3U30	Motor P3U10/20	Motor P3U30	P3F30	P3L30	P3M30	P3M32	P3G30	P3G32	P3T32
Distance	21	-	-	-	-	-	1	-	-	-	-	-
Under-impedance	21G	-	-	-	-	-	-	-	-	2	2	-
Fault locator	21FL	-	1	-	1	1	1	-	-	-	-	-
Overfluxing	24	-	-	-	-	-	-	-	-	1	1	1
Synchronization check <sup>(5)</sup>	25	-	2	-	2	2	2	2	2	2	2	2
Undervoltage	27	-	3	-	3	3	3	3	3	3	3	3
Positive sequence under-voltage	27P	-	-	-	-	-	-	-	-	2	2	-
Directional active under-power	32	-	2	-	2	2	2	2	2	2	2	2
Phase undercurrent	37	1	1	1	1	-	-	1	1	-	-	-
Temperature monitoring	38/49T	12 <sup>(4)</sup>	12 <sup>(4)</sup>	12 <sup>(4)</sup>	12 <sup>(4)</sup>	12 <sup>(4)</sup>	12 <sup>(4)</sup>	12 <sup>(4)</sup>	12 <sup>(4)</sup>	12 <sup>(4)</sup>	12 <sup>(4)</sup>	12 <sup>(4)</sup>
Loss of field	40	-	-	-	-	-	-	-	-	1	1	-
Under-reactance	21/40	-	-	-	-	-	-	-	-	2	2	-
Negative sequence overcurrent (motor, generator)	46	-	-	2	2	-	-	2	2	2	2	2
Cur. unbalance, broken conductor	46BC	1	1	-	-	1	1	-	-	-	-	-
Incorrect phase sequence	47	-	-	1	1	-	-	1	1	-	-	-
Excessive start time, locked rotor	48/51LR	-	-	1	1	-	-	1	1	-	-	-
Thermal overload	49	1	1	1	1	1	1	1	1	1	1	1
Phase overcurrent	50/51	3	3	3	3	3	3	3	3	3	3	3
Earth fault overcurrent	50N/51N	5	5	5	5	5	5	5	5	5	5	5
Breaker failure	50BF	1	1	1	1	1	1	1	1	1	1	1
SOTF	50HS	1	1	1	1	1	1	1	1	1	1	1
Capacitor bank unbalance <sup>(1)</sup>	51C	2	2	2	2	2	2	2	2	2	2	2
Voltage-dependent overcurrent	51V	-	1	-	1	1	1	-	-	1	1	-
Overvoltage	59	-	3	-	3	3	3	3	3	3	3	3
Capacitor overvoltage	59C	1	1	-	-	1	1	-	-	-	-	-
Neutral voltage displacement	59N	3	3	3	3	2	2	2	2	2	2	2
CT supervision	60	1	1	1	1	1	1	1	1	1	2	2
VT supervision	60FL	-	1	-	1	1	1	1	1	1	1	1
Restricted earth fault (low impedance)	64REF	-	-	-	-	-	-	-	-	-	1	1
Stator earth fault	64S	-	-	-	-	-	-	-	-	1	1	-
Frequent start inhibition	66	-	-	1	1	-	-	1	1	-	-	-
Directional phase overcurrent	67	-	4	-	4	4	4	4	4	4	4	4
Directional earth fault o/c	67N	3	3	3	3	3	3	3	3	3	3	3
Transient intermittent	67NI	1	1	-	-	1	1	-	-	-	-	-
Magnetizing inrush detection	68F2	1	1	1	1	1	1	1	1	1	1	1
Fifth harmonic detection	68H5	1	1	1	1	1	1	1	1	1	1	1
Pole slip	78PS	-	-	-	-	-	-	-	-	1	1	-



Protection functions	ANSI code	Feeder P3U10/20	Feeder P3U30	Motor P3U10/20	Motor P3U30	P3F30	P3L30	P3M30	P3M32	P3G30	P3G32	P3T32
Auto-Recloser	79	5	5	-	-	5	5	-	-	-	-	-
Over or under frequency	81	-	2/2	-	2/2	2/2	2/2	2/2	2/2	2/2	2/2	2/2
Rate of change of frequency	81R	-	1	-	1	1	1	1	1	1	1	1
Under frequency	81U	-	2	-	2	2	2	2	2	2	2	2
Lockout	86	1	1	1	1	1	1	1	1	1	1	1
Line differential	87L	-	-	-	-	-	2	-	-	-	-	-
Machine differential	87M	-	-	-	-	-	-	-	2	-	2	-
Transformer differential	87T	-	-	-	-	-	-	-	-	-	-	2
Programmable stages	99	8	8	8	8	8	8	8	8	8	8	8
Arc flash detection (AFD)		-	-	-	-	8	-	8	8	8	8	8
Cold load pickup (CLPU)		1	1	1	1	1	1	1	1	1	1	1
Programmable curves		3	3	3	3	3	3	3	3	3	3	3
Setting groups <sup>(2)</sup>		4	4	4	4	4	4	4	4	4	4	4

Control functions	P3U10/20	P3U30	P3F30	P3L30	P3M30	P3M32	P3G30	P3G32	P3T32
Switchgear control and monitoring	1/2	4	6	6	6	6	6	6	6
Switchgear monitoring only	-	-	2	2	2	2	2	2	2
Programmable switchgear interlocking	■	■	■	■	■	■	■	■	■
Local control on single-line diagram	■	■	■	■	■	■	■	■	■
Local control with O/I keys	■	■	■	■	■	■	■	■	■
Local/remote function	■	■	■	■	■	■	■	■	■
Function keys	2	2	2	2	2	2	2	2	2
Custom logic (logic equations)	■	■	■	■	■	■	■	■	■
Control with Smart App	■	■	■	■	■	■	■	■	■

Measurement	P3U10/20	P3U30	P3F30	P3L30	P3M30	P3M32	P3G30	P3G32	P3T32
RMS current values	■	■	■	■	■	■ <sup>(3)</sup>	■	■ <sup>(3)</sup>	■ <sup>(3)</sup>
RMS voltage values	■	■	■	■	■	■	■	■	■
RMS active, reactive and apparent power	-	■	■	■	■	■	■	■	■
Frequency	■	■	■	■	■	■	■	■	■
Fundamental frequency current values	■	■	■	■	■	■ <sup>(3)</sup>	■	■ <sup>(3)</sup>	■ <sup>(3)</sup>
Fundamental frequency voltage values	-	■	■	■	■	■	■	■	■
Fundamental frequency active, reactive and apparent power values	-	■	■	■	■	■	■	■	■
Power factor	-	■	■	■	■	■	■	■	■
Energy values active and reactive	-	■	■	■	■	■	■	■	■
Energy transmitted with pulse outputs	-	■	■	■	■	■	■	■	■
Demand values: phase currents	■	■	■	■	■	■	■	■	■
Demand values: active, reactive, apparent power and power factor	-	■	■	■	■	■	■	■	■
Min and max demand values: phase currents	■	■	■	■	■	■	■	■	■
Min and max demand values: RMS phase currents	■	■	■	■	■	■	■	■	■
Min and max demand values: active, reactive, apparent power and power factor	-	■	■	■	■	■	■	■	■

Measurement	P3U10/20	P3U30	P3F30	P3L30	P3M30	P3M32	P3G30	P3G32	P3T32
Maximum demand values over the last 31 days and 12 months: active, reactive, apparent power	-	■	■	■	■	■	■	■	■
Minimum demand values over the last 31 days and 12 months: active, reactive power	-	■	■	■	■	■	■	■	■
Max and min values: currents	■	■	■	■	■	■	■	■	■
Max and min values: voltages	-	■	■	■	■	■	■	■	■
Max and min values: frequency	■	■	■	■	■	■	■	■	■
Max and min values: active, reactive, apparent power and power factor	-	■	■	■	■	■	■	■	■
Harmonic values of phase current and THD	■	■	■	■	■	■ (3)	■	■ (3)	■ (3)
Harmonic values of voltage and THD	-	■	■	■	■	■	■	■	■
Voltage sags and swells	-	■	■	■	■	■	■	■	■

Logs and Records	P3U10/20	P3U30	P3F30	P3L30	P3M30	P3M32	P3G30	P3G32	P3T32
Sequence of event record	■	■	■	■	■	■	■	■	■
Disturbance record	■	■	■	■	■	■	■	■	■
Tripping context record	■	■	■	■	■	■	■	■	■

Monitoring functions	P3U10/20	P3U30	P3F30	P3L30	P3M30	P3M32	P3G30	P3G32	P3T32
Trip circuit supervision (ANSI 74)	1	1	1	1	1	1	1	1	1
Circuit breaker monitoring	1	1	1	1	1	1	1	1	1
Relay monitoring	■	■	■	■	■	■	■	■	■

**NOTE:**

- (1) Capacitor bank unbalance protection is connected to the earth fault overcurrent input and shares 2 stages with the earth fault overcurrent protection.
- (2) Not all protection functions have 4 setting groups. See details in the manual.
- (3) Function available on both sets of CT inputs
- (4) Using external RTD module
- (5) The availability depends on the selected voltage measurement mode (in the **Scaling** setting view in Easergy Pro).

---

## 2.3 Presentation

### Protection functions

- Universal, adaptive protection functions for user-configurable applications like feeder, motor and voltage protection from basic non-directional to directional overcurrent protection and thermal overload
- Neutral voltage displacement, overvoltage and frequency protection including synchrocheck for two breakers
- Single-line diagram, measurements and alarms in the user-machine interface (UMI)
- User-configurable interlocking for primary object control
- Current and voltage injection by manipulating the database of the product by setting tool disturbance recorder file playback through the product's database

### Robust hardware

- User-selectable Ethernet, RS485 or RS232 -based communication interfaces
- Designed for demanding industrial conditions with conformal-coated printed circuit boards
- Standard USB connection (type B) for Easergy Pro setting software

### Common technology for cost efficiency

- Powerful CPU supporting IEC 61850
- Thanks to four setting groups, adaptation to various protection schemes is convenient

### User-machine interface (UMI)

- Clear LCD display for alarms and events
- Single-line diagram mimic with control, indication and live measurements
- Programmable function keys and LEDs
- Circuit breaker ON/OFF control
- Common firmware platform with other other Easergy P3 range protection relays

## 2.4 Operating levels

The relay has three operating levels: **User**, **Operator** and **Configurator**. The purpose of the access levels is to prevent accidental or unwanted change of relay configurations, parameters or settings.

### USER level

Use:	Possible to read for example parameter values, measurements and events
Opening:	Level permanently open
Closing:	Closing not possible

### OPERATOR level

Use:	Possible to control objects and to change for example the settings of the protection stages
Opening:	The default password is 1.
Closing:	The level is automatically closed after 10 minutes idle time. Giving the password 9999 also closes the level.

### CONFIGURATOR level

Use:	The configurator level is needed during the commissioning of the relay. For example the scaling of the voltage and current transformers can be set.
Opening:	The default password is 2.
Closing:	The level is automatically closed after 10 minutes idle time. Giving the password 9999 also closes the level.

## Logging in via the front panel





1. Push  and  on the front panel. The **Enter password** view opens.



Figure 2.1: *Enter password* view

2. Enter the password for the desired access level. Select the desired digit value using , and if the password is longer than one digit, move to the next digit position using .

**NOTE:** There are 16 digit positions in the **Enter password** view. Enter the password starting from the first digit position.

Example: If the password is 2, you may enter 2\*\*\* or \*\*2\* or \*\*\*2 to log in. Do not type number 0 if it is not part of the password.

3. Push  to confirm the password.

## Password handling

You can change the passwords:

- in the **General > Device info** setting view in Easergy Pro connected to the USB port in the relay's front panel
- via Ethernet using Easergy Pro or the web server

**NOTE:** The password can contain 1-16 digits (no alphabets).

It is possible to restore a password if the password is lost or forgotten. To restore a password, a relay program is needed. The virtual serial port settings are 38400 bps, 8 data bits, no parity and 1 stop bit. The bit rate is configurable via the front panel.

Command	Description
get pwd_break	Get the break code (Example: 6569403)
get serno	Get the serial number of the relay (Example: 12345)

Send both numbers to your nearest Schneider Electric Customer Care Centre and ask for a password break. A relay-specific break code is sent back to you. That code is valid for the next two weeks.

Command	Description
set pwd_break=4435876	Restore the factory default passwords ("4435876" is just an example. The actual code should be asked from your nearest Schneider Electric Customer Care Centre.)

Now the passwords are restored to the default values.

### Login to HTTP server and FTP

Protocol	Login name	Login password
HTTP	conf	2
FTP	easergy	config

## 2.5 Front panel

Easergy P3M30 and P3M32 has a 128 x 128 LCD matrix display.

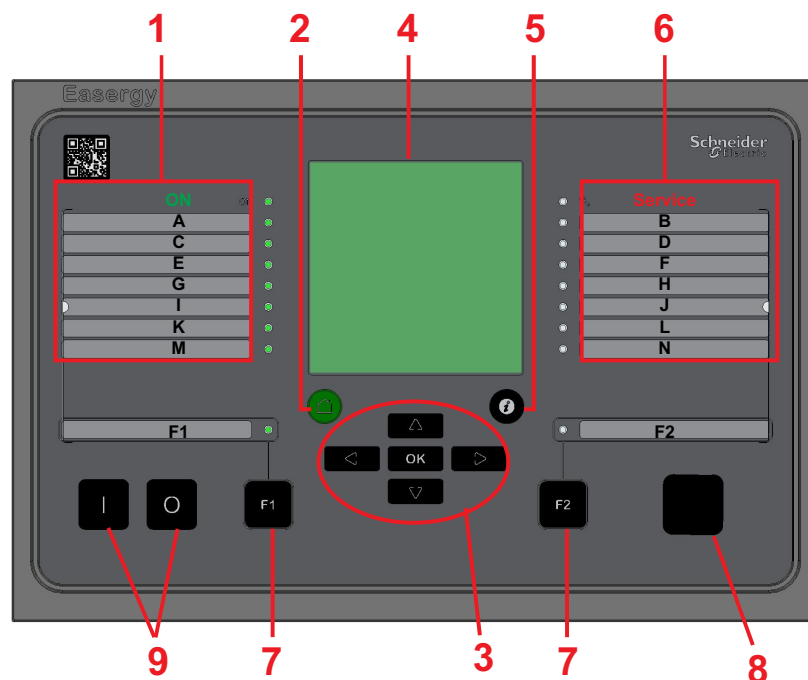

Figure 2.2: Easergy P3M30 and P3M32 front panel

- 1 Power LED and 7 programmable LEDs
- 2 CANCEL push-button
- 3 Navigation push-buttons
- 4 LCD
- 5 INFO push-button
- 6 Status LED and 7 programmable LEDs
- 7 Function push-buttons and LEDs showing their status
- 8 Local port
- 9 Object control buttons

## 2.5.1 Push-buttons

### Symbol Function



HOME/CANCEL push-button for returning to the previous menu. To return to the first menu item in the main menu, press the button for at least 3 seconds.



INFO push-button for viewing additional information, for entering the password view and for adjusting the LCD contrast.



Programmable function push-button. (\*)



Programmable function push-button. (\*)



ENTER push-button for activating or confirming a function.



UP navigation push-button for moving up in the menu or increasing a numerical value.



DOWN navigation push-button for moving down in the menu or decreasing a numerical value.



LEFT navigation push-button for moving backwards in a parallel menu or selecting a digit in a numerical value.



RIGHT navigation push-button for moving forwards in a parallel menu or selecting a digit in a numerical value.



Circuit breaker ON push-button



Circuit breaker OFF push-button

#### NOTE:

\*) The default names of the function buttons are Function button 1 and 2. You can change the names of the buttons in the **Inputs/outputs > Names for logic outputs** setting view.

## 2.5.2 LED indicators

The relay has 18 LEDs on the front panel:

- 2 LEDs for function buttons (F1 and F2)
- 2 LEDs represent the unit's general status (POWER and STATUS)
- 14 user-configurable LEDs (A - N)

When the relay is powered, the "POWER" LED lits as green. During normal use, the "STATUS" LED is not active, it activates only when an error occurs or the relay is not operating correctly. Should this happen, contact your local representative for further guidance.

The "STATUS" LED and watchdog contact are assigned to work together. Hardwire the status output into the substation's automation system for alarm purposes.

A LED can lit either green or red. The LEDs on the front panel can be configured in Easergy Pro.

To customise the LED texts on the front panel, the texts can be written on a template and then printed on a transparency. The transparencies can be placed in the pockets beside the LEDs.

You can also customize the LED texts that are shown on the screen for active LEDs via Easergy Pro.

### Configuring the LED names via Easergy Pro

1. Go to **General > LED names**.
2. To change a LED name, click the LED **Description** text and type a new name. To save the new name, press **Enter**.



**Led Names**

LED	Description	LED	Description
LED A (green)	LED A (green)	LED B (green)	LED B (green)
LED A (red)	LED A (red)	LED B (red)	LED B (red)
LED C (green)	LED C (green)	LED D (green)	LED D (green)
LED C (red)	LED C (red)	LED D (red)	LED D (red)
LED E (green)	LED E (green)	LED F (green)	LED F (green)
LED E (red)	LED E (red)	LED F (red)	LED F (red)
LED G (green)	LED G (green)	LED H (green)	LED H (green)
LED G (red)	LED G (red)	LED H (red)	LED H (red)
LED I (green)	LED I (green)	LED J (green)	LED J (green)
LED I (red)	LED I (red)	LED J (red)	LED J (red)
LED K (green)	LED K (green)	LED L (green)	LED L (green)
LED K (red)	LED K (red)	LED L (red)	LED L (red)
LED M (green)	LED M (green)	LED N (green)	LED N (green)
LED M (red)	LED M (red)	LED N (red)	LED N (red)



Figure 2.3: LED NAMES menu in Easergy Pro for LED configuration

### 2.5.3 Controlling the alarm screen

You can enable or disable the alarm screen either via the relay's local display or using Easergy Pro:





- On the local display, go to **Events > Alarms**.
- In Easergy Pro, go to **General > Local panel conf**.

### 2.5.4 Accessing operating levels

1. On the front panel, press  and .
2. Enter the four-digit password and press .

## 2.5.5 Adjusting the LCD contrast

Prerequisite: You have entered the correct password.

1. Press  and adjust the contrast.
  - To increase the contrast, press .
  - To decrease the contrast, press .
2. To return to the main menu, press .

**NOTE:** By nature, the LCD display changes its contrast depending on the ambient temperature. The display may become dark or unreadable at low temperatures. However, this condition does not affect the proper operation of the protection or other functions.

## 2.5.6 Testing the LEDs and LCD screen

You can start the test sequence in any main menu window.

To start the LED and LCD test:







1. Press .
2. Press .

The relay tests the LCD screen and the functionality of all LEDs.

## 2.5.7 Controlling an object with selective control

Prerequisite: You have entered the correct password and enabled selective control in the OBJECTS setting view.



When selective control is enabled, the control operation needs confirmation (select before operate).

1. Press  to close object.
  - Press  again to confirm.
  - Press  to cancel.
2. Press  to open object.
  - Press  again to confirm.
  - Press  to cancel.

## 2.5.8 Controlling an object with direct control

Prerequisite: You have entered the correct password and enabled selective control in the OBJECTS setting view.

When direct control is enabled, the control operation is done without confirmation.

1. Log in to the system.
2. Press  to close object.
3. Press  to open object.

## 2.5.9 Menus

This section gives an overview of the menus that you can access via the relay's front panel.

### The main menu

Press the right arrow to access more measurements in the main menu.

**Table 2.1: Main menu**

Menu name	Description
Active LEDs	User-configurable texts for active LEDs
Measurements	User-configurable measurements
Single line	Single line or Single line mimic, measurements and control view. This is a default start view. To return to this view from any location, press the HOME/CANCEL button for at least 3 seconds.
Info	Information about the relay: relay's name, order code, date, time and firmware version
P	Power: power factor and frequency values calculated by the relay. Press the right arrow to view more energy measurements.
E	Energy: the amount of energy that has passed through the protected line, calculated by the relay from the currents and voltages. Press the right arrow to view more energy measurements.
I	Current: phase currents and demand values of phase currents. Press the right arrow to view more current measurements.
U	Line-to-line voltages. Press the right arrow to view other voltage measurements.
Dema	Minimum and maximum phase current and power demand values
Umax	Minimum and maximum values of voltage and frequency
Imax	Minimum and maximum voltage values
Pmax	Minimum and maximum power values
Month	Monthly maximum current and power values
FL	Short-circuit locator applied to incomer or feeder
Evnt	Event log: event codes and time stamps
DR	Disturbance recorder configuration settings

Menu name	Description
Runh	Running hour counter
TIMR	Timers: programmable timers that you can use to preset functions
DI	Digital input statuses and settings
DO	Digital output statuses and settings
Arc	Arc flash protection settings
Prot	Protection: settings and statuses for various protection functions
I>, I>>, etc.	Protection stage settings and statuses. The availability of the menus are depends on the activated protection stages.
AR	Auto-reclosure settings, statuses and registers
OBJ	Objects: settings related to object status data and object control (open/closed)
Lgic	Logic events and counters
CONF	General device setup: CT and VT scalings, frequency adaptation, units, device info, date, time, clock, etc.
Bus	Communication port settings
Slot	Slot info: card ID (CID) that is the name of the card used by the relay firmware
Diag	Diagnosis: various diagnostic information

**Moving in the menus**

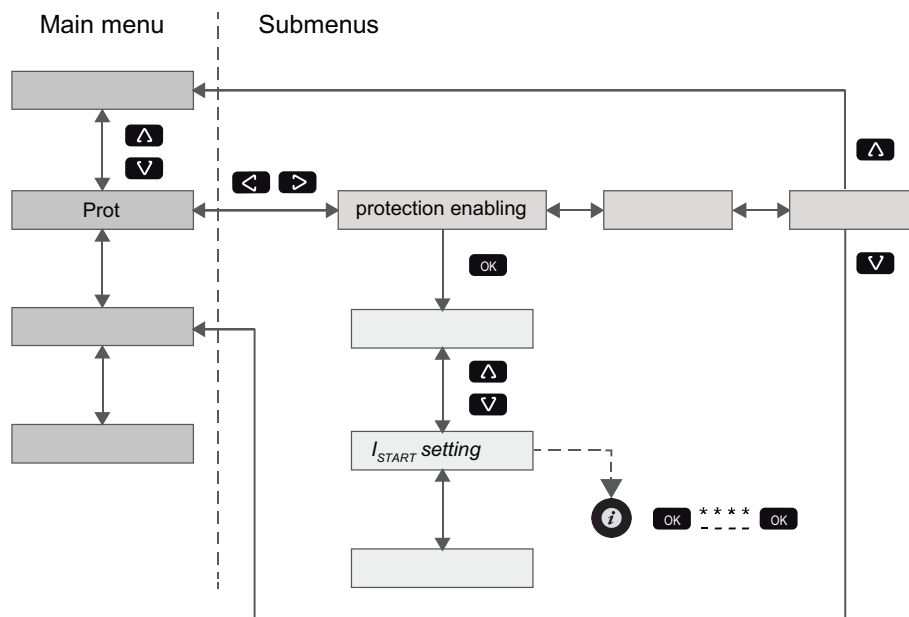















Figure 2.4: Moving in menus using the front panel

- To move in the main menu, press  or .
- To move in the submenus, press  or .
- While in the submenu, press  or  to jump to the root.
- To enter a submenu, press  and use  or  for moving down or up in the menu.
- To edit a parameter value, press  and . Enter the four-digit password and press .
- To go back to the previous menu, press .
- To go back to the first menu item in the main menu, press  for at least three seconds.

**NOTE:** To enter the parameter edit mode, enter the password. When the value is in edit mode, its background is dark.

### Local panel messages

Value is not editable:	The value can not be edited or password is not given
Control disabled:	Object control disabled due to wrong operating level
Change will cause autoboot:	Notification that if the parameter is changed the relay boots itself

## 2.6 Easergy Pro setting and configuration tool

### DANGER

#### HAZARD OF ELECTRIC SHOCK, EXPLOSION, OR ARC FLASH

Only qualified personnel should operate this equipment. Such work should be performed only after reading this entire set of instructions and checking the technical characteristics of the device.

**Failure to follow this instruction will result in death or serious injury.**

Easergy Pro is a software tool for configuring Easergy P3 relays. It has a graphical interface where the relay settings and parameters are grouped under seven tabs:

- General
- Measurements
- Inputs/outputs
- Protection
- Matrix
- Logs
- Communication

The contents of the tabs depend on the relay type and the selected application mode.

Easergy Pro stores the relay configuration in a setting file. The configuration of one physical relay is saved in one setting file. The configurations can be printed out and saved for later use.

For more information, see the Easergy Pro user manual.

### ***NOTICE***

#### **RISK OF SYSTEM SHUTDOWN**

After writing new settings or configurations to a relay, perform a test to verify that the relay operates correctly with the new settings.

**Failure to follow these instructions can result in unwanted shutdown of the electrical installation.**

# 3 Mechanical structure

## 3.1 Modularity

The relay has a modular structure. The relay is built from hardware modules that are installed into 10 different slots at the back of the relay. The location of the slots is shown in Figure 3.1.

The type of the hardware modules is defined by the order code.

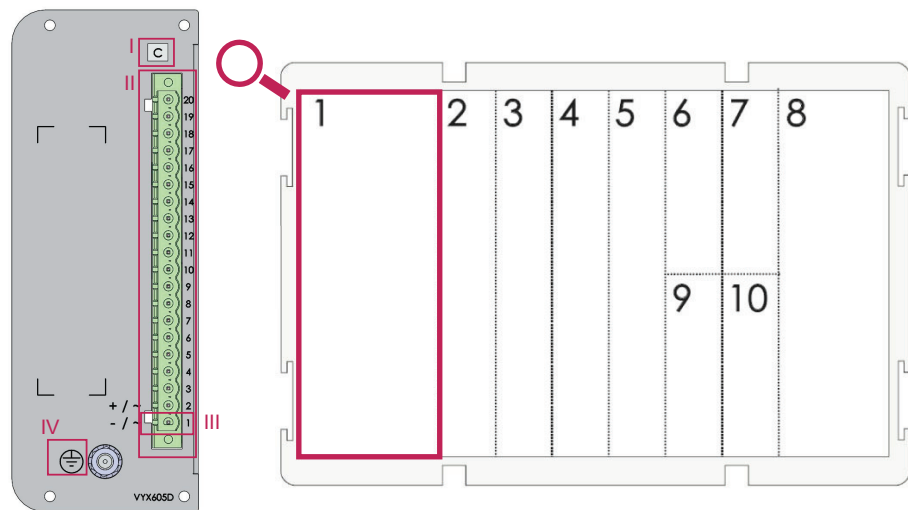

I	Card C	1	Supply voltage [V]
II	Connector 2	2, 3	I/O card
III	Pin 1	4, 5	I/O or analog measurement card
IV	Protective grounding	6, 9	Communication or I/O option card
		7, 8, 10	Analog measurement card (I, U)
		9, 10	Communication interface I and II

Figure 3.1: Slot numbering and card options in the Easergy P3M30 and P3M32 rear panel and an example of defining the pin address 1/C/1:1

For complete availability information on the different option cards, see Chapter 13 Order code.

Chapter 10.5 Connections contains detailed information on each card.

**Table 3.1: Example of typical model P3M32-CGIII-DAENA-BB**

SLOT	NAME	TYPE
	Application	M32 = Motor protection relay
1	Supply voltage	C = 110 – 240 Vac/dc (6 x DO: 1 change over signal duty and 5 tripping duty)
2	I/O card I	G = 6DI+4DO (6 x DI, 4 x DO)
3	I/O card II	I = 10DI (10 x DI)
4	I/O card III	I = 10DI (10 x DI)
5	I/O card IV	I = 10DI (10 x DI)
6	Option card I	D = 4Arc (4 x Arc sensor)
7	Future option	A = None
8	Analog measurement card (See application)	E = 3L(5A)+4U+2IO (5/1A+1/0.2A)
9	Communication interface I	N = 2 x RJ (Ethernet RJ 100Mbps, RSTP, PRP)
10	Future option	A = None
	Display type	B = 128x128 (128 x 128 LCD matrix)
	DI nominal voltage	B = 110 Vdc/ac, with conformal coating
	Digital inputs	36 pcs
	Trip contacts	9 pcs
	Alarm contacts	1 pc
	Self-supervision contact	1 pc
	Phase currents (5A)	3 pcs
	Voltage channels	4 pcs
	Earth fault overcurrents (5/1A + 1/0.2A)	2 pcs
	Display	fixed in the relay



## 3.2 Slot info and order code

The relay's configuration can be checked via the front panel or Easergy Pro menu called **Slot** or **Slot info**. "Card ID" is the name of the card used by the relay firmware.

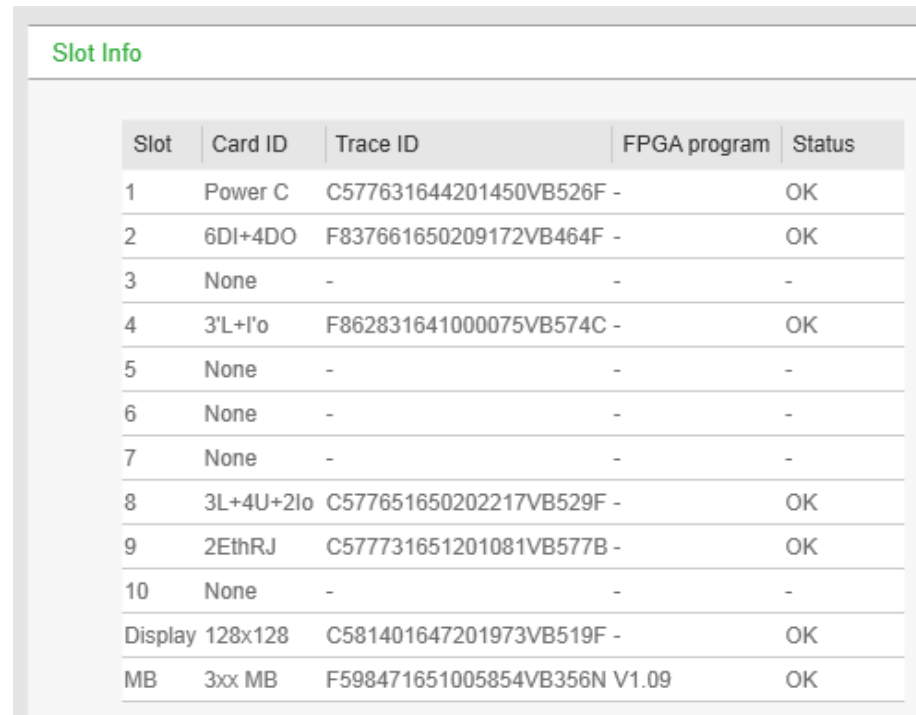

Slot	Card ID	Trace ID	FPGA program	Status
1	Power C	C577631644201450VB526F -		OK
2	6DI+4DO	F837661650209172VB464F -		OK
3	None	-	-	-
4	3'L+I'o	F862831641000075VB574C -		OK
5	None	-	-	-
6	None	-	-	-
7	None	-	-	-
8	3L+4U+2lo	C577651650202217VB529F -		OK
9	2EthRJ	C577731651201081VB577B -		OK
10	None	-	-	-
Display	128x128	C581401647201973VB519F -		OK
MB	3xx MB	F598471651005854VB356N V1.09		OK

Figure 3.2: Hardware configuration example view from Easergy Pro configuration tool.

**NOTE:** See Chapter 13 Order code for the relay ordering options.

# 4 Measurement functions

Easergy P3 has various amounts of analog inputs depending on the model in use. Table 4.1 introduces directly measured and calculated quantities for the power system monitoring. See Chapter 2.2 Product selection guide.

The current scaling impacts the following functions:

- Protection stages
- Measurements
- Disturbance recorder
- Fault location calculation

**Table 4.1: Measurement functions in Easergy P3**

Measurements Specification	P3U1020	P3U30	P3x3x	Measurement range	Inaccuracy
RMS phase current	■	■	■	$0.025-50 \times I_N$	$I \leq 1.5 \times I_N$ : $\pm 0.5$ % of value or $\pm 15$ mA $I > 1.5 \times I_N$ : $\pm 3$ % of value
RMS earth fault overcurrent	■	■	■	$0.003-2 \times I_N$	$I \leq 1.5 \times I_{0N}$ : $\pm 0.3$ % of value or $\pm 0.2$ % of $I_{0N}$ $I > 1.5 \times I_{0N}$ : $\pm 3$ % of value
RMS line-to-line voltage	-	■	■	$0.005-1.7 \times U_N$	$\pm 0.5$ % or $\pm 0.3$ V
RMS phase-to-neutral voltage	-	■	■	$0.005-1.7 \times U_N$	$\pm 0.5$ % or $\pm 0.3$ V
RMS active power (PF >0.5)	-	■	■	$\pm 0.1-1.5 \times P_N$	$\pm 1$ % for range $0.3-1.5 \times P_N$ $\pm 3$ % for range $0.1-0.3 \times P_N$
RMS reactive power (PF >0.5)	-	■	■	$\pm 0.1-1.5 \times Q_N$	$\pm 1$ % for range $0.3-1.5 \times Q_N$ $\pm 3$ % for range $0.1-0.3 \times Q_N$
RMS apparent power (PF >0.5)	-	■	■	$\pm 0.1-1.5 \times S_N$	$\pm 1$ % for range $0.3-1.5 \times S_N$ $\pm 3$ % for range $0.1-0.3 \times S_N$
Frequency	■	■	■	16 Hz-75 Hz	$\pm 10$ mHz
Fundamental frequency current values	■	■	■	$0.025-50 \times I_N$	$I \leq 1.5 \times I_N$ : $\pm 0.5$ % of value or $\pm 15$ mA $I > 1.5 \times I_N$ : $\pm 3$ % of value
Fundamental frequency voltage values	-	■	■	$0.005-1.7 \times U_N$	$\pm 0.5$ % or $\pm 0.3$ V
Fundamental frequency active, reactive and apparent power values	-	■	■	$\pm 0.1-1.5 \times P_N$	$\pm 1$ % for range $0.3-1.5 \times P_N$ $\pm 3$ % for range $0.1-0.3 \times P_N$
Fundamental frequency active power values	-	■	■	$\pm 0.1-1.5 \times Q_N$	$\pm 1$ % for range $0.3-1.5 \times Q_N$ $\pm 3$ % for range $0.1-0.3 \times Q_N$
Fundamental frequency reactive power values	-	■	■	$\pm 0.1-1.5 \times S_N$	$\pm 1$ % for range $0.3-1.5 \times S_N$ $\pm 3$ % for range $0.1-0.3 \times S_N$
Power factor	-	■	■	0.02-1	$\pm 2^\circ$ or $\pm 0.02$ for PF > 0.5
Active energy	-	■	■		$\pm 1$ % for range $0.3-1.5 \times EP_N$
Reactive energy	-	■	■		$\pm 1$ %/1h for range $0.3-1.5 \times EQ_N$ $\pm 3$ %/1h for range $0.1-0.3 \times EQ_N$
Energy transmitted with pulse outputs	-	■	■		$\pm 1$ %/1h for range $0.3-1.5 \times EP_N$ $\pm 3$ %/1h for range $0.1-0.3 \times EP_N$

## 4 Measurement functions

Measurements Specification	P3U1020	P3U30	P3x3x	Measurement range	Inaccuracy
Demand values: phase currents	■	■	■	$0.025-50 \times I_N$	$I \leq 1.5 \times I_N$ : $\pm 0.5\%$ of value or $\pm 15$ mA $I > 1.5 \times I_N$ $\pm 3\%$ of value
Active power demand	-	■	■	$\pm 0.1-1.5 \times P_N$	$\pm 1\%$ for range $0.3-1.5 \times P_N$ $\pm 3\%$ for range $0.1-0.3 \times P_N$
Reactive power demand	-	■	■	$\pm 0.1-1.5 \times Q_N$	$\pm 1\%$ for range $0.3-1.5 \times Q_N$ $\pm 3\%$ for range $0.1-0.3 \times Q_N$
Apparent power demand	-	■	■	$\pm 0.1-1.5 \times S_N$	$\pm 1\%$ for range $0.3-1.5 \times S_N$ $\pm 3\%$ for range $0.1-0.3 \times S_N$
Power factor demand	-	■	■		$\pm 2^\circ$ or $\pm 0.02$ for PF > 0.5
Min and max demand values: phase currents	■	■	■	$0.025-50 \times I_N$	$I \leq 1.5 \times I_N$ : $\pm 0.5\%$ of value or $\pm 15$ mA $I > 1.5 \times I_N$ $\pm 3\%$ of value
Min and max demand values: RMS phase currents	■	■	■	$0.025-50 \times I_N$	$I \leq 1.5 \times I_N$ : $\pm 0.5\%$ of value or $\pm 15$ mA $I > 1.5 \times I_N$ $\pm 3\%$ of value
Min and max demand values: active, reactive, apparent power and power factor	-	■	■		$\pm 1\%$ for range $0.3-1.5 \times P_N, Q_N, S_N$ $\pm 3\%$ for range $0.1-0.3 \times P_N, Q_N, S_N$
Maximum demand values over the last 31 days and 12 months: active, reactive, apparent power	-	■	■		$\pm 1\%$ for range $0.3-1.5 \times P_N, Q_N, S_N$ $\pm 3\%$ for range $0.1-0.3 \times P_N, Q_N, S_N$
Minimum demand values over the last 31 days and 12 months: active, reactive power	-	■	■		$\pm 1\%$ for range $0.3-1.5 \times P_N, Q_N, S_N$ $\pm 3\%$ for range $0.1-0.3 \times P_N, Q_N, S_N$
Max and min values: currents	■	■	■	$0.025-50 \times I_N$	$I \leq 1.5 \times I_N$ : $\pm 0.5\%$ of value or $\pm 15$ mA $I > 1.5 \times I_N$ $\pm 3\%$ of value
Max and min values: voltages	-	■	■	$0.005-1.7 \times U_N$	$\pm 0.5\%$ or $\pm 0.3$ V
Max and min values: frequency	■	■	■	16 Hz-75 Hz	$\pm 10$ mHz
Max and min values: active, reactive, apparent power and power factor	-	■	■	$\pm 0.1-1.5 \times P_N, Q_N, S_N$	$\pm 1\%$ for range $0.3-1.5 \times P_N, Q_N, S_N$ $\pm 3\%$ for range $0.1-0.3 \times P_N, Q_N, S_N$ $\pm 2^\circ$ or $\pm 0.02$ for PF > 0.5
Harmonic values of phase current and THD	■	■	■	2nd-15th	
Harmonic values of voltage and THD	-	■	■	2nd-15th	
Voltage sags and swells	-	■	■	$0.005-1.7 \times U_N$	$\pm 2^\circ$ or $\pm 0.02$ for PF > 0.5

NOTE: Measurement display's refresh rate is 0.2 s.

## 4.1 Primary, secondary and per unit scaling

Many measurement values are shown as primary values although the relay is connected to secondary signals. Some measurement values are shown as relative values - per unit or per cent. Almost all start setting values use relative scaling.

The phase current and earth fault overcurrent scaling parameters are listed in Table 4.2.

**Table 4.2: Scaling parameters**

Parameter	Description
Motor nominal current	Nominal current of the motor
CT' primary	Primary current value of the current transformer at I' side (only P3x32 relays)
CT' secondary	Secondary current value of the current transformer at I' side (only P3x32 relays)
Nominal input (IL side)	Rated value of the phase current input. The given thermal withstand, burden and impedance are based on this value. See Table 10.28 for details.
Nominal input (I'L side)	Rated value of the phase current input at I' side. The given thermal withstand, burden and impedance are based on this value (only P3x32 relays). See Table 10.28 for details.
CT primary	Primary current value of the IL current transformer
CT secondary	Secondary current value of the IL current transformer
Io1 CT primary	Primary current value of the earth fault Io1 overcurrent transformer
Io1 CT secondary	Secondary current value of the earth fault Io1 overcurrent transformer
Nominal Io1 input	Selectable nominal input rating for the earth fault overcurrent input. Select either 5A or 1A depending on which Io input is used. The given thermal withstand, burden and impedance are based on this value. See Table 10.28 for details.
Io2 CT primary	Primary current value of the earth fault Io2 overcurrent transformer
Io2 CT secondary	Secondary current value of the earth fault Io2 overcurrent transformer
Nominal Io2 input	Selectable nominal input rating for the earth fault overcurrent input. Select either 1A or 0.2A depending on which Io input is used. The given thermal withstand, burden and impedance are based on this value. See Table 10.28 for details.
Io3 CT primary	Primary current value of the earth fault Io3 overcurrent transformer
Io3 CT secondary	Secondary current value of the earth fault Io3 overcurrent transformer
Nominal Io3 input	Selectable nominal input rating for the earth fault overcurrent input. Select either 1A or 0.2A depending on which Io input is used. The given thermal withstand, burden and impedance are based on this value. See Table 10.26 for details.
VT primary	Primary voltage value of the voltage transformer
VT secondary	Secondary voltage value of the voltage transformer
VTo secondary	Secondary voltage value of the neutral voltage displacement voltage transformer

Parameter	Description
Voltage measurement mode	The relay can be connected either to zero-sequence voltage, line-to-line voltage or line-to-neutral voltage. Set the voltage measurement mode according to the type of connection used.
Frequency adaptation mode	Parameter used to set the system frequency. There are three modes available: manual, auto and fixed. For more information, see section Frequency adaptation mode.
Adapted frequency	When the frequency adaption mode is set to manual, you can set the frequency in the <b>Adapted frequency</b> field, and it is not be updated even if the measured frequency is different.
Angle memory duration	Time setting for the directional overcurrent stage to keep the phase angle fixed if the system voltage collapses
I' 180 deg. angle turn	A setting to turn I' currents 180 degrees (only P3x32 relays)

The **Scaling** setting view in Easergy Pro is shown in Figure 4.1

**Scaling**

---

**CT settings**

CT primary	<input type="range" value="500"/>	500	A
CT secondary	<input type="range" value="5"/>	5	A
CT' primary	<input type="range" value="500"/>	500	A
CT' secondary	<input type="range" value="5"/>	5	A
Nominal input (I'L side)	<input type="text" value="5"/>	5	A
Io1 CT primary	<input type="range" value="50"/>	50	A
Io1 CT secondary	<input type="range" value="5.0"/>	5.0	A
Nominal Io1 input	<input type="text" value="5.0"/>	5.0	A
Io2 CT primary	<input type="range" value="50"/>	50	A
Io2 CT secondary	<input type="range" value="5.0"/>	5.0	A
Nominal Io2 input	<input type="text" value="1.0"/>	1.0	A
Io3 CT primary	<input type="range" value="50"/>	50	A
Io3 CT secondary	<input type="range" value="5.0"/>	5.0	A
Nominal Io3 input	<input type="text" value="5.0"/>	5.0	A

---

**VT settings**

VT primary	<input type="range" value="11000"/>	11000	V
VT secondary	<input type="range" value="100"/>	100	V
VTo secondary	<input type="range" value="100.000"/>	100.000	V

---

Voltage meas. mode	<input type="text" value="3LN+Uo"/>	3LN+Uo	
Frequency adaptation mode	<input type="text" value="Auto"/>	Auto	
Adapted frequency	<input type="range" value="50.0"/>	50.0	Hz
Angle memory duration	<input type="range" value="0.50"/>	0.50	s
I' 180 deg. angle turn	<input type="checkbox"/>		

---

Motor nominal current	<input type="range" value="400.0"/>	400.0	A
-----------------------	-------------------------------------	-------	---

Figure 4.1: Scaling setting view

The scaling equations presented in Chapter 4.1.2 Current scaling and Chapter 4.1.3 Voltage scaling for analogue module E, F are useful when doing secondary testing.

## 4.1.1 Frequency adaptation mode

You can set the system frequency in **General > Scaling** in Easergy Pro. See .

There are three frequency adaptation modes available:

- **Manual:** When the adaption mode is set to manual, you can set the frequency in the **Adapted frequency** field, and it will not be updated even if the measured frequency is different. However, the relay monitors the system frequency internally and adapts to the new frequency even if the frequency has been set manually.
- **Auto:** The network frequency is automatically updated when the relay has measured the voltage for approximately 45 seconds. The **Adapted frequency** field is updated even if it has been set previously. The frequency is measured from the voltage signals listed in Table 4.3.

**Table 4.3: Voltage signals**

Voltage measurement mode	Voltage	Voltage channel
2LL+U <sub>0</sub> , 2LL+U <sub>0</sub> /LNy, 2LL+U <sub>0</sub> /LLy	U12, U23	U1, U2
3LN, 3LN+U <sub>0</sub> , 3LN/LNy, 3LN/LLy	UL1, UL2	U1, U2
LN+U <sub>0</sub> /yz	UL1	U1
LL+U <sub>0</sub> /yz	U12	U1

- **Fixed:** The frequency is not updated based on the measured voltage and only the set value is used. This mode is recommended to be used for the line-differential function.

## 4.1.2 Current scaling

**NOTE:** The rated value of the relay's current input, for example 5 A or 1A, does not have any effect in the scaling equations, but it defines the measurement range and the maximum allowed continuous current. See Table 10.28 for details.

### Primary and secondary scaling

	Current scaling
secondary → primary	$I_{PRI} = I_{SEC} \cdot \frac{CT_{PRI}}{CT_{SEC}}$
primary → secondary	$I_{SEC} = I_{PRI} \cdot \frac{CT_{SEC}}{CT_{PRI}}$

For earth fault overcurrent to input  $I_0$ , use the corresponding  $CT_{PRI}$  and  $CT_{SEC}$  values. For ground fault stages using  $I_{0Calc}$  signals, use the phase current CT values for  $CT_{PRI}$  and  $CT_{SEC}$ .

### Examples:

1. **Secondary to primary**

$$CT = 500 / 5$$

Current to the relay's input is 4 A.

$$\Rightarrow \text{Primary current is } I_{PRI} = 4 \times 500 / 5 = 400 \text{ A}$$

2. **Primary to secondary**

$$CT = 500 / 5$$

The relay displays  $I_{PRI} = 400 \text{ A}$

$$\Rightarrow \text{Injected current is } I_{SEC} = 400 \times 5 / 500 = 4 \text{ A}$$



### Per unit [pu] scaling

For phase currents excluding Arcl> stage:

$1 \text{ pu} = 1 \times I_{MOT} = 100 \%$ , where  $I_{MOT}$  is the rated current of the motor.  
The rated current for high voltage side (HV) and low voltages side (LV) are calculated by the relay itself using Equation 4.1.

Equation 4.1:

$$I_{MOT} = \frac{S_{MOT}}{\sqrt{3} \cdot U_{MOT}}$$

$I_{MOT}$  = The rated current 1 pu.

$S_{MOT}$  = Rated apparent power of the protected relay

$U_{MOT}$  = Rated line-to-line voltage of the protected relay

For earth fault overcurrents and Arcl> stage:

$1 \text{ pu} = 1 \times CT_{SEC}$  for secondary side and  $1 \text{ pu} = 1 \times CT_{PRI}$  for primary side.

	Phase current scaling excluding Arcl> stage	Earth fault overcurrent ( $3I_0$ ) scaling and phase current scaling for Arcl> stage
secondary → per unit	$I_{PU} = \frac{I_{SEC} \cdot CT_{PRI}}{CT_{SEC} \cdot I_{MOT}}$	$I_{PU} = \frac{I_{SEC}}{CT_{SEC}}$
per unit → secondary	$I_{SEC} = I_{PU} \cdot CT_{SEC} \cdot \frac{I_{MOT}}{CT_{PRI}}$	$I_{SEC} = I_{PU} \cdot CT_{SEC}$

### Examples:

#### 1. Secondary to per unit for Arcl>

$$CT = 750 / 5$$

Current injected to the relay's inputs is 7 A.

$$\text{Per unit current is } I_{PU} = 7 / 5 = 1.4 \text{ pu} = 140 \%$$

#### 2. Secondary to per unit for phase currents excluding Arcl>

$$CT = 750/5$$

$$I_{MOT} = 525 \text{ A}$$

Current injected to the relay's inputs is 7 A.

$$\text{Per unit current is } I_{PU} = 7 \times 750 / (5 \times 525) = 2.00 \text{ pu} = 2.00 \times I_{MOT} = 200 \%$$

**3. Per unit to secondary for Arcl>**

$$CT = 750 / 5$$

The relay setting is 2 pu = 200 %.

$$\text{Secondary current is } I_{SEC} = 2 \times 5 = 10 \text{ A}$$

**4. Per unit to secondary for phase currents excluding Arcl>**

$$CT = 750 / 5$$

$$I_{MOT} = 525 \text{ A}$$

The relay setting is  $2 \times I_{MOT} = 2 \text{ pu} = 200 \%$ .

$$\text{Secondary current is } I_{SEC} = 2 \times 5 \times 525 / 750 = 7 \text{ A}$$

**5. Secondary to per unit for earth fault overcurrent**

Input is  $I_{01}$ .

$$CT_0 = 50 / 1$$

Current injected to the relay's input is 30 mA.

$$\text{Per unit current is } I_{PU} = 0.03 / 1 = 0.03 \text{ pu} = 3 \%$$

**6. Secondary to per unit for earth fault overcurrent**

Input is  $I_{01}$ .

$$CT_0 = 50 / 1$$

The relay setting is 0.03 pu = 3 %.

$$\text{Secondary current is } I_{SEC} = 0.03 \times 1 = 30 \text{ mA}$$

**7. Secondary to per unit for earth fault overcurrent**

Input is  $I_{0Calc}$ .

$$CT = 750 / 5$$

Currents injected to the relay's  $I_{L1}$  input is 0.5 A.

$$I_{L2} = I_{L3} = 0.$$

$$\text{Per unit current is } I_{PU} = 0.5 / 5 = 0.1 \text{ pu} = 10 \%$$

**8. Secondary to per unit for earth fault overcurrent**

Input is  $I_{0Calc}$ .

$$CT = 750 / 5$$

The relay setting is 0.1 pu = 10 %.

If  $I_{L2} = I_{L3} = 0$ , then secondary current to  $I_{L1}$  is

$$I_{SEC} = 0.1 \times 5 = 0.5 \text{ A}$$

### 4.1.3 Voltage scaling for analogue module E, F

**NOTE:** Voltage transformer scaling is based on the line-to-line voltages in all voltage measurements modes.

#### Primary/secondary scaling of line-to-line voltages

	Line-to-line voltage scaling	
	Voltage measurement mode = "2LL+U <sub>0</sub> "	Voltage measurement mode = "3LN"
secondary → primary	$U_{PRI} = U_{SEC} \cdot \frac{VT_{PRI}}{VT_{SEC}}$	$U_{PRI} = \sqrt{3} \cdot U_{SEC} \cdot \frac{VT_{PRI}}{VT_{SEC}}$
primary → secondary	$U_{SEC} = U_{PRI} \cdot \frac{VT_{SEC}}{VT_{PRI}}$	$U_{SEC} = \frac{U_{PRI}}{\sqrt{3}} \cdot \frac{VT_{SEC}}{VT_{PRI}}$

#### Examples

- Secondary to primary. Voltage measurement mode is "2LL+U<sub>0</sub>"**  
 VT = 12000/110  
 Voltage connected to the relay's input U<sub>A</sub> or U<sub>B</sub> is 100 V.  
 => Primary voltage is U<sub>PRI</sub> = 100x12000/110 = 10909 V.
- Secondary to primary. Voltage measurement mode is "3LN"**  
 VT = 12000/110  
 Three phase symmetric voltages connected to the relay's inputs U<sub>A</sub>, U<sub>B</sub> and U<sub>C</sub> are 57.7 V.  
 => Primary voltage is U<sub>PRI</sub> = √3 x 57.7x12000/110 = 10902 V
- Primary to secondary. Voltage measurement mode is "2LL+U<sub>0</sub>"**  
 VT = 12000/110  
 The relay displays U<sub>PRI</sub> = 10910 V.  
 => Secondary voltage is U<sub>SEC</sub> = 10910x110/12000 = 100 V
- Primary to secondary. Voltage measurement mode is "3LN"**  
 VT = 12000/110  
 The relay displays U<sub>12</sub> = U<sub>23</sub> = U<sub>31</sub> = 10910 V.  
 => Symmetric secondary voltages at U<sub>A</sub>, U<sub>B</sub> and U<sub>C</sub> are U<sub>SEC</sub> = 10910/√3 x 110/12000 = 57.7 V.

**Per unit [pu] scaling of line-to-line voltages**

One per unit = 1 pu =  $1 \times U_N = 100\%$ , where  $U_N$  = rated voltage of the VT.

	Line-to-line voltage scaling	
	Voltage measurement mode = "2LL+U <sub>0</sub> ", "1LL+U <sub>0</sub> /LLy", "2LL/LLy", "LL/LLy/LLz"	Voltage measurement mode = "3LN"
secondary → per unit	$U_{PU} = \frac{U_{SEC}}{VT_{SEC}} \cdot \frac{VT_{PRI}}{U_N}$	$U_{PU} = \sqrt{3} \cdot \frac{U_{SEC}}{VT_{SEC}} \cdot \frac{VT_{PRI}}{U_N}$
per unit → secondary	$U_{SEC} = U_{PU} \cdot VT_{SEC} \cdot \frac{U_N}{VT_{PRI}}$	$U_{SEC} = U_{PU} \cdot \frac{VT_{SEC}}{\sqrt{3}} \cdot \frac{U_N}{VT_{PRI}}$

**Examples**

1. **Secondary to per unit. Voltage measurement mode is "2LL+U<sub>0</sub>"**

VT = 12000/110

Voltage connected to the relay's input  $U_A$  or  $U_B$  is 110 V.

=> Per unit voltage is  $U_{PU} = 110/110 = 1.00$  pu =  $1.00 \times U_N = 100\%$

2. **Secondary to per unit. Voltage measurement mode is "3LN"**

VT = 12000/110

Three symmetric phase-to-neutral voltages connected to the relay's inputs  $U_A$ ,  $U_B$  and  $U_C$  are 63.5 V

=> Per unit voltage is  $U_{PU} = \sqrt{3} \times 63.5 / 110 \times 12000 / 11000 = 1.00$  pu =  $1.00 \times U_N = 100\%$

3. **Per unit to secondary. Voltage measurement mode is "2LL+U<sub>0</sub>"**

VT = 12000/110

The relay displays 1.00 pu = 100 %.

=> Secondary voltage is  $U_{SEC} = 1.00 \times 110 \times 11000 / 12000 = 100.8$  V

4. **Per unit to secondary. Voltage measurement mode is "3LN"**

VT = 12000/110

$U_N = 11000$  V

The relay displays 1.00 pu = 100 %.

=> Three symmetric phase-to-neutral voltages connected to the relay's inputs  $U_A$ ,  $U_B$  and  $U_C$  are

$U_{SEC} = 1.00 \times 110 / \sqrt{3} \times 11000 / 12000 = 58.2$  V

## Per unit [pu] scaling of neutral displacement voltage

	Neutral displacement voltage ( $U_0$ ) scaling	
	Voltage measurement mode = "2LL+ $U_0$ ", "1LL+ $U_0$ /LLy"	Voltage measurement mode = "3LN"
secondary → per unit	$U_{PU} = \frac{U_{SEC}}{U_{0SEC}}$	$U_{PU} = \frac{1}{VT_{SEC}} \cdot \frac{ \bar{U}_a + \bar{U}_b + \bar{U}_c _{SEC}}{\sqrt{3}}$
per unit → secondary	$U_{SEC} = U_{PU} \cdot U_{0SEC}$	$ \bar{U}_a + \bar{U}_b + \bar{U}_c _{SEC} = \sqrt{3} \cdot U_{PU} \cdot VT_{SEC}$

## Examples

- 1. Secondary to per unit. Voltage measurement mode is "2LL+ $U_0$ "**

$U_{0SEC} = 110$  V (This is a configuration value corresponding to  $U_0$  at full earth fault.)

Voltage connected to the relay's input  $U_C$  is 22 V.

=> Per unit voltage is  $U_{PU} = 22/110 = 0.20$  pu = 20 %
- 2. Secondary to per unit. Voltage measurement mode is "3LN"**

$VT = 12000/110$

Voltage connected to the relay's input  $U_A$  is 38.1 V, while  $U_B = U_C = 0$ .

=> Per unit voltage is  $U_{PU} = (38.1+0+0)/(\sqrt{3} \times 110) = 0.20$  pu = 20 %
- 3. Per unit to secondary. Voltage measurement mode is "2LL+ $U_0$ "**

$U_{0SEC} = 110$  V (This is a configuration value corresponding to  $U_0$  at full earth fault.)

The relay displays  $U_0 = 20$  %.

=> Secondary voltage at input  $U_C$  is  $U_{SEC} = 0.20 \times 110 = 22$  V
- 4. Per unit to secondary. Voltage measurement mode is "3LN"**

$VT = 12000/110$

The relay displays  $U_0 = 20$  %.

=> If  $U_B = U_C = 0$ , then secondary voltages at  $U_A$  is

$U_{SEC} = \sqrt{3} \times 0.2 \times 110 = 38.1$  V

## 4.2 Measurements for protection functions

The relay uses root mean square (RMS) measurement for the protection stages if not stated otherwise in the protection stage description.

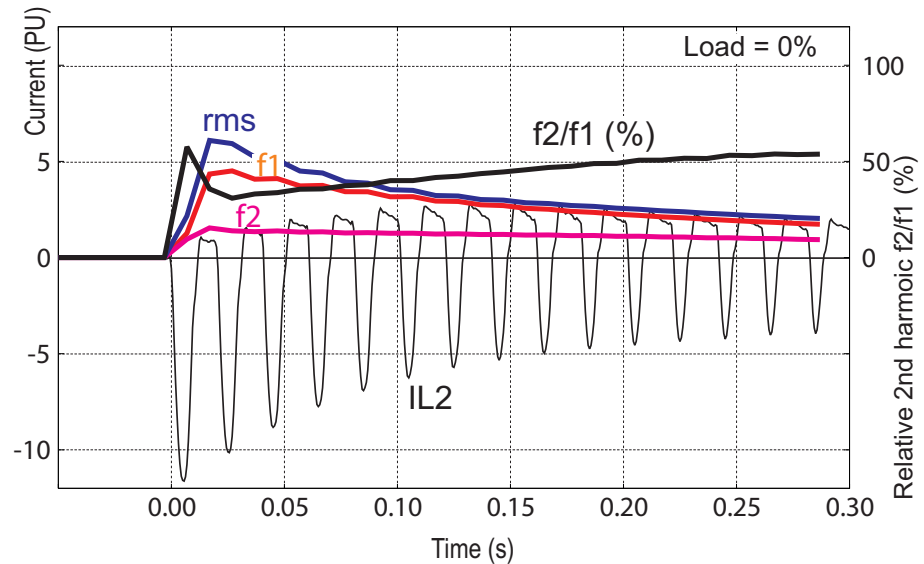

Figure 4.2: Example of various current values of a transformer inrush current

All the direct measurements are based on fundamental frequency values. The exceptions are frequency and instantaneous current for arc protection. Most protection functions are also based on the fundamental frequency values.

Figure 4.2 shows a current waveform and the corresponding fundamental frequency component  $f_1$ , second harmonic  $f_2$ , and RMS value in a special case where the current deviates significantly from a pure sine wave.

## 4.3 Measurements for arc protection function

The three-phase current measurement and ground fault current measurement for arc protection are done with electronics (see Figure 4.3). The electronics compares the current levels to the start settings - THRESHOLDS - and gives a binary signals “I>” or “I<sub>01</sub>>” to the arc protection function if limit is exceeded. All the frequency components of the currents are taken into account.

Signals “I>” or “I<sub>0</sub>>” are connected to a FPGA chip which implements the arc protection function. The start settings are named “I> int” and “I<sub>01</sub>> int” in the local LCD panel or Easergy Pro views, these settings are used to set the THRESHOLD levels for the electronics.

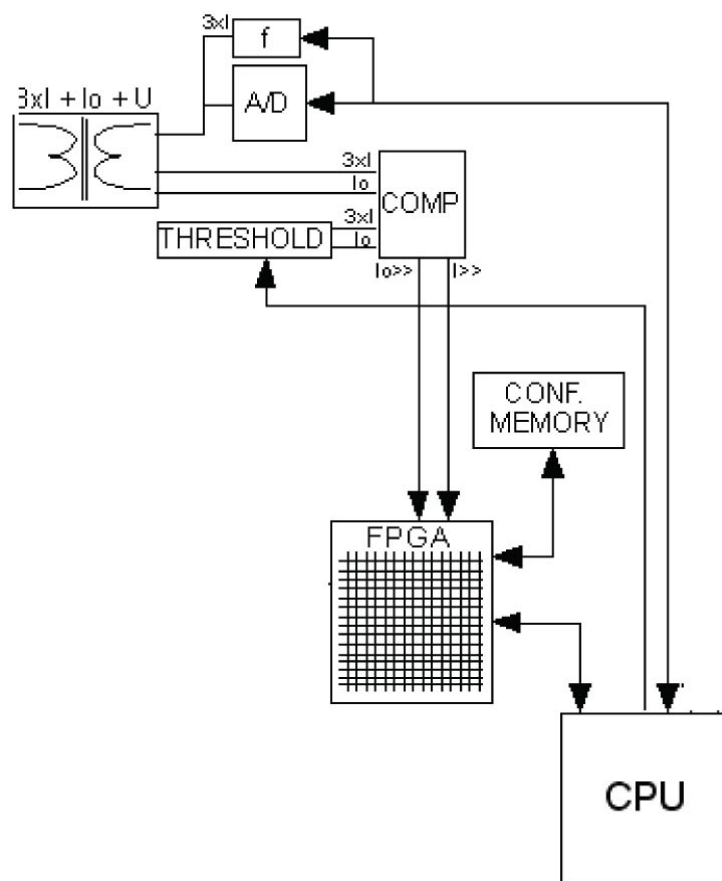

Figure 4.3: Measurement logic for the arc flash protection function

## 4.4 RMS values

### RMS currents

The relay calculates the RMS value of each phase current. The minimum and maximum RMS values are recorded and stored (see Chapter 4.7 Minimum and maximum values).

$$I_{RMS} = \sqrt{I_{f1}^2 + I_{f2}^2 + \dots + I_{f15}^2}$$

### RMS voltages

The relay calculates the RMS value of each voltage input. The minimum and the maximum of RMS values are recorded and stored (see Chapter 4.7 Minimum and maximum values).

$$U_{RMS} = \sqrt{U_{f1}^2 + U_{f2}^2 + \dots + U_{f15}^2}$$

## 4.5 Harmonics and total harmonic distortion (THD)

The relay calculates the the total harmonic distortions (THDs) as a percentage of the currents and voltages values measured at the fundamental frequency. The relay calculates the harmonics from the 2nd to the 15th of phase currents and voltages. (The 17th harmonic component is also shown partly in the value of the 15th harmonic component. This is due to the nature of digital sampling.)

The harmonic distortion is calculated

$$THD = \frac{\sqrt{\sum_{i=2}^{15} f_i^2}}{h_1} \quad \begin{array}{l} f_1 = \text{Fundamental value} \\ f_{2-15} = \text{Harmonics} \end{array}$$

### Example

$$f_1 = 100 \text{ A}, \quad f_3 = 10 \text{ A}, \quad f_7 = 3 \text{ A}, \quad f_{11} = 8 \text{ A}$$

$$THD = \frac{\sqrt{10^2 + 3^2 + 8^2}}{100} = 13.2\%$$

For reference the RMS value is

$$RMS = \sqrt{100^2 + 10^2 + 3^2 + 8^2} = 100.9 \text{ A}$$

Another way to calculate THD is to use the RMS value as reference instead of the fundamental frequency value. In the example above, the result would then be 13.0 %.



## 4.6 Demand values

The relay calculates average i.e. demand values of phase currents  $I_{L1}$ ,  $I_{L2}$ ,  $I_{L3}$  and power values S, P and Q.

The demand time is configurable from 10 to 60 minutes with the parameter "Demand time".

Figure 4.4: Demand values

Table 4.4: Demand value parameters

Parameter	Value	Unit	Description	Set
Time	10 – 30	min	Demand time (averaging time)	Set
<b>Fundamental frequency values</b>				
IL1da		A	Demand of phase current IL1	
IL2da		A	Demand of phase current IL2	
IL3da		A	Demand of phase current IL3	
Pda		kW	Demand of active power P	
PFda			Demand of power factor PF	
Qda		kvar	Demand of reactive power Q	
Sda		kVA	Demand of apparent power S	
<b>RMS values</b>				
IL1RMSda		A	Demand of RMS phase current IL1	
IL2RMSda		A	Demand of RMS phase current IL2	
IL3RMSda		A	Demand of RMS phase current IL3	
Prmsda		kW	Demand of RMS active power P	
Qrmsda		kvar	Demand of RMS reactive power Q	
Srmsda		kVA	Demand of RMS apparent power S	

Set = An editable parameter (password needed).

## 4.7 Minimum and maximum values

Minimum and maximum values are registered with time stamps since the latest manual clearing or since the relay has been restarted. The available registered values are listed in Table 4.5.

Figure 4.5: Minimum and maximum values

Table 4.5: Minimum and maximum measurement values

Min & Max measurement	Description
IL1, IL2, IL3	Phase current, fundamental frequency value
IL1RMS, IL2RMS, IL3RMS	Phase current, RMS value
$I_{01}$ , $I_{02}$	Earth fault overcurrent, fundamental value
$U_A$ , $U_B$ , $U_C$ , $U_D$	Voltages, fundamental frequency values
$U_{ARMS}$ , $U_{BRMS}$ , $U_{CRMS}$ , $U_{DRMS}$	Line-to-neutral voltages, RMS value
f	Frequency
P, Q, S	Active, reactive, apparent power
P.F.	Power factor

The clearing parameter "ClrMax" is common for all these values.

Table 4.6: Parameters

Parameter	Value	Description	Set
ClrMax	-; Clear	Reset all minimum and maximum values	Set

Set = An editable parameter (password needed).

# 4.8 Maximum values of the last 31 days and 12 months

The maximum and minimum values of the last 31 days and the last 12 months are stored in the relay's non-volatile memory.

**NOTE:** The saving process starts every 30 minutes and it takes a while. If the relay's auxiliary supply power is switched off before all values have been saved, the old values remain for the unsaved ones.

Corresponding time stamps are stored for the last 31 days. The registered values are listed in Table 4.7.

**Month max**

Timebase for maximums

Reset 31 days max

Reset month max

**PAST 31 DAYS**

Measurement	Date	Time of day
0	2017-04-12	22:44:39
0	2017-04-12	22:44:39
0	2017-04-12	22:44:39
0.00	2017-04-12	22:44:39

Description	Measurement	Date	Time of day
Pmax	0	2017-04-12	22:44:39
Pmin	0	2017-04-12	22:44:39
Qmax	0	2017-04-12	22:44:39
Qmin	0	2017-04-12	22:44:39
Smax	0	2017-04-12	22:44:39

**PAST 12 MONTHS**

Month	Year	IL1max	IL2max	IL3max	Iomax	Pmax	Pmin	Qmax	Qmin	Smax
JANUARY	2017	0	0	0	0.00	0	0	0	0	0
FEBRUARY	2017	0	0	0	0.00	0	0	0	0	0
MARCH	2017	0	0	0	0.00	0	0	0	0	0
APRIL	2017	0	0	0	0.00	0	0	0	0	0
MAY	2016	0	0	0	0.00	0	0	0	0	0
JUNE	2016	0	0	0	0.00	0	0	0	0	0
JULY	2016	0	0	0	0.00	0	0	0	0	0
AUGUST	2016	0	0	0	0.00	0	0	0	0	0
SEPTEMBER	2016	0	0	0	0.00	0	0	0	0	0
OCTOBER	2016	0	0	0	0.00	0	0	0	0	0
NOVEMBER	2016	0	0	0	0.00	0	0	0	0	0
DECEMBER	2016	0	0	0	0.00	0	0	0	0	0

Figure 4.6: Past 31 days and 12 month maximums/minimums can be viewed in “month max” menu.

**Table 4.7: Maximum registered values of the last 31 days and 12 months**

12 months Measurement	Max	Min	Description	31 days	12 months
IL1, IL2, IL3	X		Phase current (fundamental frequency value)		
Io1, Io2	X		Earth fault overcurrent		
S	X		Apparent power	X	X
P	X	X	Active power	X	X
Q	X	X	Reactive power	X	X

The timebase can be a value from one cycle to one minute. Also a demand value can be used as the timebase and its value can be set between 10 and 60 minutes. The demand value menu is located under the “MEASUREMENTS” view.

**Table 4.8: Parameters of the day and month registers**

Parameter	Value	Description	Set
Timebase		Parameter to select the type of the registered values	Set
	20 ms	Collect min & max of one cycle values (*)	
	200 ms	Collect min & max of 200 ms average values	
	1 s	Collect min & max of 1 s average values	
	1 min	Collect min & max of 1 minute average values	
	demand	Collect min & max of demand values (Chapter 4.6 Demand values)	
ResetDays		Reset the 31 day registers	Set
ResetMon		Reset the 12 month registers	Set

Set = An editable parameter (password needed).

(\*) This is the fundamental frequency RMS value of one cycle updated every 20 ms.

# 4.9 Power and current direction

Figure 4.7 shows the concept of three-phase current direction and sign of  $\cos\phi$  and power factor PF (the absolute value is equal to  $\cos\phi$ , but the sign is 'IND' for inductive i.e. lagging current and 'CAP' for capacitive i.e. leading current). Figure 4.8 shows the same concepts on a PQ-power plane.

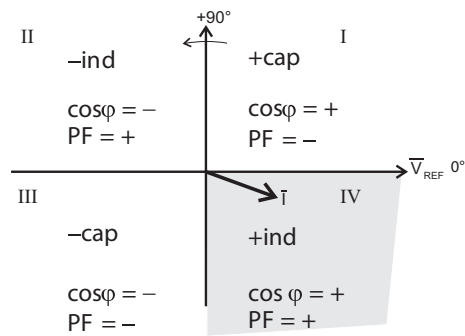

Figure 4.7: Quadrants of voltage/current phasor plane

- I: Forward capacitive power current is leading
- II: Reverse inductive power current is leading
- III: Reverse capacitive power current is lagging
- IV: Forward inductive power current is lagging

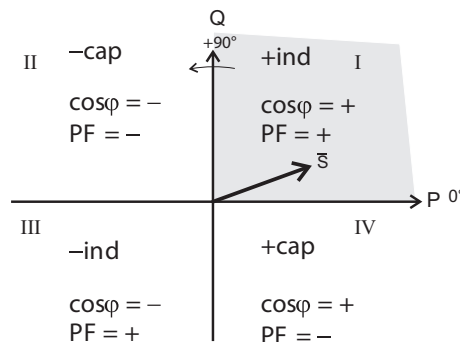

Figure 4.8: Quadrants of power plane

- I: Forward inductive power current is lagging
- II: Reverse capacitive power current is lagging
- III: Reverse inductive power current is leading
- IV: Forward capacitive power current is leading

Table 4.9: Power quadrants

Power quadrant	Current related to voltage	Power direction	$\cos\phi$	Power factor PF
+ inductive	Lagging	Forward	+	+
+ capacitive	Leading	Forward	+	-
- inductive	Leading	Reverse	-	+
- capacitive	Lagging	Reverse	-	-

## 4.10 Symmetric components

In a three-phase system, the voltage or current phasors may be divided in symmetric components.

- Positive sequence 1
- Negative sequence 2
- Zero sequence 0

Symmetric components are calculated according to the following equations:

$$\begin{bmatrix} \underline{S}_0 \\ \underline{S}_1 \\ \underline{S}_2 \end{bmatrix} = \frac{1}{3} \begin{bmatrix} 1 & 1 & 1 \\ 1 & \underline{a} & \underline{a}^2 \\ 1 & \underline{a}^2 & \underline{a} \end{bmatrix} \begin{bmatrix} \underline{S}_A \\ \underline{S}_B \\ \underline{S}_C \end{bmatrix}$$

$\underline{S}_0$  = zero sequence component

$\underline{S}_1$  = positive sequence component

$\underline{S}_2$  = negative sequence component

$$\underline{a} = 1 \angle 120^\circ = -\frac{1}{2} + j \frac{\sqrt{3}}{2}, \text{ a phase rotating constant}$$

$\underline{S}_A$  = phasor of phase L1 (phase current or voltage)

$\underline{S}_B$  = phasor of phase L2

$\underline{S}_C$  = phasor of phase L3

# 5 Control functions

## 5.1 Digital outputs

The digital outputs are also called controlling outputs, signaling outputs and self-supervision outputs. Trip contacts can be controlled by using the relay output matrix or logic function. Also forced control is possible. To use forced control, you must enable it in the **Relays** setting view.

Any internal signal can be connected to the digital outputs in the **Matrix > Arc matrix - output** setting views.

The **Output matrix** and **Relays** setting views represent the state (de-energized / energized) of the digital output's coil. For example, a bright green vertical line in the **Output matrix** and a logical "1" in the **Relays** view represent the energized state of the coil. The same principle applies for both NO and NC type digital outputs. The actual position (open / closed) of the digital outputs' contacts in coil's de-energized and energized state depends on the type (NO / NC) of the digital outputs. De-energized state of the coil corresponds to the normal state of the contacts. A digital output can be configured as latched or non-latched. Chapter 5.5 Releasing latches describes releasing latches procedure.

The difference between trip contacts and signal contacts is the DC breaking capacity. The contacts are **single pole single throw (SPST)** normal open (NO) type, except signal relay A1 which has a changeover contact **single pole double throw (SPDT)**.

In addition to this, the relay has so called heavy duty outputs available in the power supply modules C and D. For more details, see Table 10.28.

### Programming matrix

1. Connected (single bullet)
2. Connected and latched (single bullet rounded with another circle)
3. Not connected (line crossing is empty)

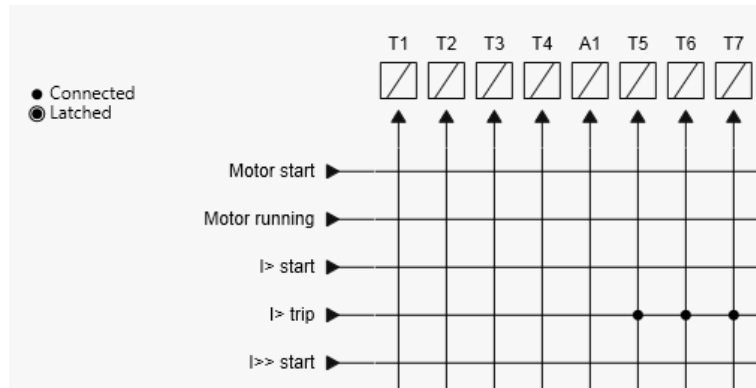

Figure 5.1: Trip contacts can be connected to protection stages or other similar purpose in the **Output matrix** setting view

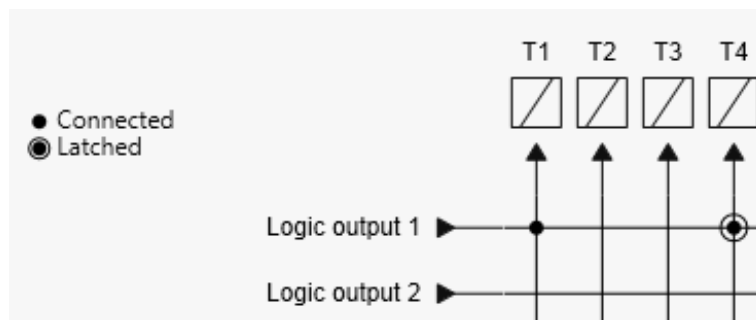

Figure 5.2: Trip contacts can be assigned directly to outputs of logical operators

**NOTE:** Logic outputs are assigned automatically in the output matrix as well when logic is built.

Trip contact status can be viewed and forced to operate in the **Relays** setting view. Logical "0" means that the output is not energized and logical "1" states that the output is set active.

**RELAYS**

---

Trip relay 1

Trip relay 2

---

Force flag

Figure 5.3: **Relays** setting view

### Default numbering of DI / DO

Every option card and slot has default numbering. Below is an example of model P3x30 CGGII-AAEAA-BA showing the default numbering of digital outputs.

You can see the default digital output numbering and change the numbering of the following option cards in the **Inputs/Outputs > Relay config** setting view: slot 2, 3, 4, 5: G, I.



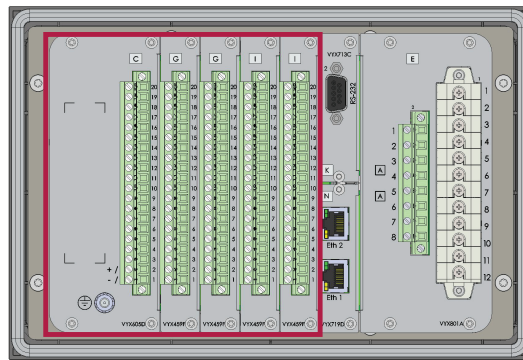

C: T1, T9 – 12, A1, SF  
 G: T13-16  
 G: T17-20  
 I: -  
 I: -

Figure 5.4: Default numbering of digital outputs for model P3x30-CGGII-AAEAA-BA

Power supply card outputs are not visible in the **Relay config** setting view.

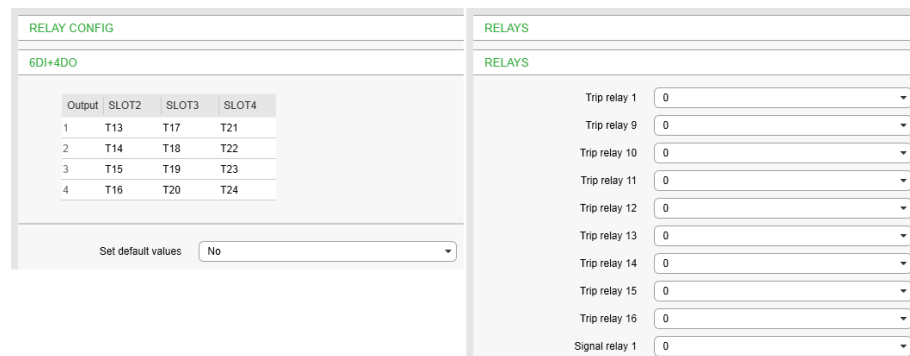

Figure 5.5: Relay config setting view

Table 5.1: Parameters of digital outputs

Parameter	Value	Unit	Description	Note
T1 – Tx the available parameter list depends on the number and type of the I/O cards.	0 1		Status of trip controlling output	F
A1	0 1		Status of alarm signalling output	F
SF	0 1		Status of the SF relay In Easergy Pro, it is called as "Service status output"	F
Force	On Off		Force flag for digital output forcing for test purposes.	Set
<b>Names for output relays (editable with Easergy Pro only)</b>				
Description	String of max. 32 characters		Names for DO on Easergy Pro screens. Default is "Trip relay n", n=1 – x or "Signal relay n", n=1	Set

F = Editable when force flag is on. Set = An editable parameter (password needed).

## 5.2 Digital inputs

Digital inputs are available for control purposes. The number of available inputs depends on the number and type of option cards. The polarity normal open (NO) / normal closed (NC) and a delay can be configured according to the application by using the front panel or Easergy Pro.

Digital inputs can be used in many operations. The status of the input can be checked in the **Output matrix** and **Digital inputs** setting views. The digital inputs make it possible to change group, block/enable/disable functions, to program logics, indicate object status, etc.

The digital inputs require an external control voltage (ac or dc). The digital inputs are activated after the activation voltage is exceeded. Deactivation follows when the voltage drops below threshold limit. The activation voltage level of digital inputs can be selected in the order code when such option cards are equipped.

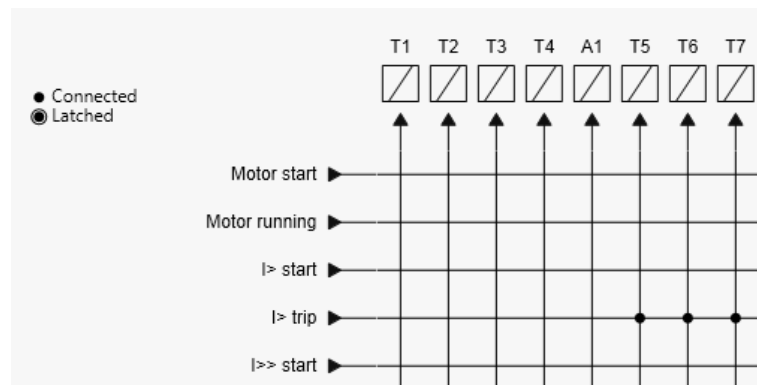

Figure 5.6: Digital inputs can be connected, latched or unlatched to trip contacts or other similar purpose in **Output matrix** setting view.

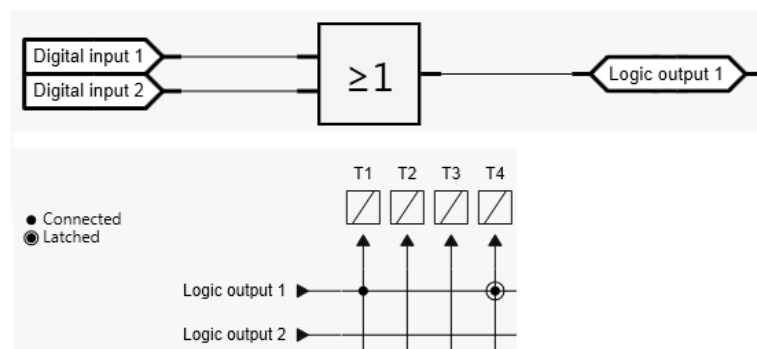

Figure 5.7: Digital inputs can be assigned, latched or unlatched directly to inputs/outputs of logical operators.

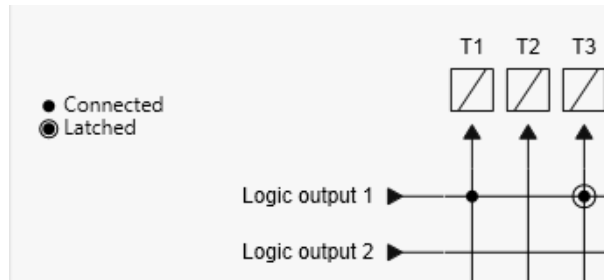

Figure 5.8: Digital inputs can be viewed, named and changed between NO/NC in **Digital inputs** setting view.

If inputs are energized by using ac voltage, “mode” has to be selected as ac.

All essential information on digital inputs can be found in the same location in the **Digital inputs** setting view. DI on/off events and alarm display (pop-up) can be enabled and disabled in **Digital inputs** setting view. Individual operation counters are located in the same view as well.

Label and description texts can be edited with Easergy Pro according to the demand. Labels are the short parameter names used on the local panel and descriptions are the longer names used by Easergy Pro.

The digital input activation thresholds are hardware-selectable.

Digital input delay determines the activation and de-activation delay for the input. Figure 5.9 shows how the digital input behaves when the delay is set to 1 second.

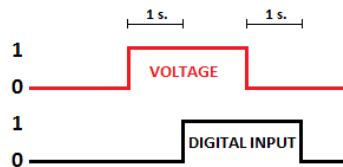

Figure 5.9: Digital inputs behaviour when delay is set to 1 second.

**Table 5.2: Parameters of digital inputs**

Parameter	Value	Unit	Description	Note
Mode	dc, ac		Used voltage of digital inputs	Set
Input	DI1 – DIx		Number of digital input. The available parameter list depends on the number and type of the I/O cards.	
Slot	2 – 6		Card slot number where option card is installed.	
State	0, 1		Status of digital input 1 – digital input x.	
Polarity	NO NC		For normal open contacts (NO). Active edge is 0 > 1 For normal closed contacts (NC) Active edge is 1 > 0	Set
Delay	0.00 – 60.00	s	Definite delay for both on and off transitions	Set
On event	On		Active edge event enabled	Set
	Off		Active edge event disabled	
Off event	On		Inactive edge event enabled	Set
	Off		Inactive edge event disabled	
Alarm display	no		No pop-up display	Set
	yes		Alarm pop-up display is activated at active DI edge	
Counters	0 – 65535		Cumulative active edge counter	(Set)
<b>NAMES for DIGITAL INPUTS (editable with Easergy Pro only)</b>				
Label	String of max. 10 characters		Short name for DIs on the local display Default is "DI1 – DIx". x is the maximum number of the digital input.	Set
Description	String of max. 32 characters		Long name for DIs. Default is "Digital input 1 – Digital input x". x is the maximum number of the digital input.	Set

Set = An editable parameter (password needed).

Every option card and slot has default numbering. After making any changes to the numbering, read the settings from the relay after the relay has rebooted.

Below is an example of model P3x30-CGGII-AAEAA-BAAAA showing default numbering of DI.

You can see the default digital input numbering and change the numbering of the following option cards in the **Inputs/Outputs > Digital inputs** setting view: slot 2, 3, 4, 5: G, I.

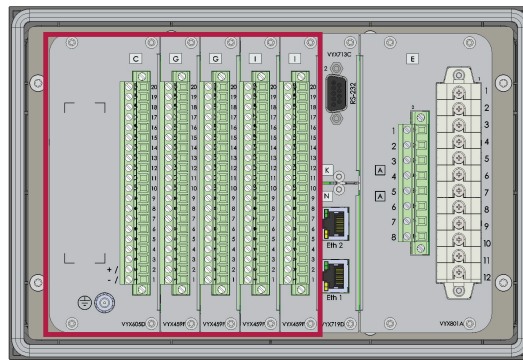

- C: -
- G: DI1-6
- G: DI7-12
- I: DI13-22
- I: DI23-32

Figure 5.10: Default numbering of digital inputs for model P3x30-CGGII-AAEAA-BA

**Digital inputs**

Mode: DC

Counters max value: 16 bit

**Digital inputs**

Input	Slot	State	Polarity	Delay	On Event	Off Event	Alarm display	Counters
1	2	0	NO	0.00 s	<input checked="" type="checkbox"/>	<input checked="" type="checkbox"/>	<input checked="" type="checkbox"/>	0
2	2	0	NO	0.00 s	<input checked="" type="checkbox"/>	<input checked="" type="checkbox"/>	<input checked="" type="checkbox"/>	0
3	2	0	NO	0.00 s	<input checked="" type="checkbox"/>	<input checked="" type="checkbox"/>	<input checked="" type="checkbox"/>	0
4	2	0	NO	0.00 s	<input checked="" type="checkbox"/>	<input checked="" type="checkbox"/>	<input checked="" type="checkbox"/>	0
5	2	0	NO	0.00 s	<input checked="" type="checkbox"/>	<input checked="" type="checkbox"/>	<input checked="" type="checkbox"/>	0
6	2	0	NO	0.00 s	<input checked="" type="checkbox"/>	<input type="checkbox"/>	<input type="checkbox"/>	0
7	3	0	NO	0.00 s	<input checked="" type="checkbox"/>	<input type="checkbox"/>	<input type="checkbox"/>	0
8	3	0	NO	0.00 s	<input checked="" type="checkbox"/>	<input checked="" type="checkbox"/>	<input checked="" type="checkbox"/>	0
9	3	0	NO	0.00 s	<input checked="" type="checkbox"/>	<input checked="" type="checkbox"/>	<input checked="" type="checkbox"/>	0
10	3	0	NO	0.00 s	<input checked="" type="checkbox"/>	<input checked="" type="checkbox"/>	<input checked="" type="checkbox"/>	0
11	3	0	NO	0.00 s	<input checked="" type="checkbox"/>	<input checked="" type="checkbox"/>	<input checked="" type="checkbox"/>	0
12	3	0	NO	0.00 s	<input checked="" type="checkbox"/>	<input type="checkbox"/>	<input type="checkbox"/>	0
13	4	0	NO	0.00 s	<input checked="" type="checkbox"/>	<input checked="" type="checkbox"/>	<input checked="" type="checkbox"/>	0

Figure 5.11: Digital inputs setting view

## 5.3 Virtual inputs and outputs

There are virtual inputs and virtual outputs that can in many places be used like their hardware equivalents except that they are located in the memory of the relay. The virtual inputs act like normal digital inputs. The status of the virtual input can be changed via the local display, communication bus and Easergy Pro. For example setting groups can be changed using virtual inputs.

Virtual inputs can be used in many operations. The status of the input can be checked in the **Output matrix** and **Virtual inputs** setting views. The status is also visible on local mimic display, if so selected. Virtual inputs can be selected to be operated with the function buttons F1 and F2, the local mimic or simply by using the virtual input menu. Virtual inputs have similar functions as digital inputs: they enable changing groups, block/enable/disable functions, to program logics and other similar to digital inputs.

The activation and reset delay of the input is approximately 5 ms.

**NOTE:** The default names of the logic outputs are Logic output 1-n. You can change the names of the outputs in the **General > Names for logic outputs** setting view.

**Table 5.3: Virtual input and output**

Number of inputs	20
Number of outputs	20
Activation time / Reset time	< 5 ms

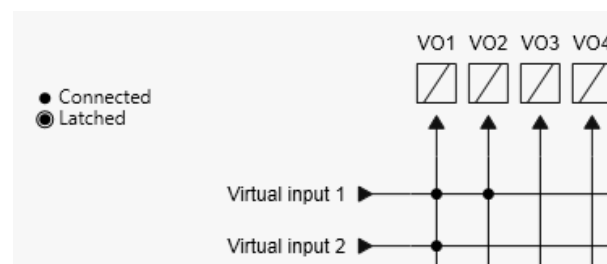

**Figure 5.12:** Virtual inputs and outputs can be used for many purpose in the **Output matrix** setting view.

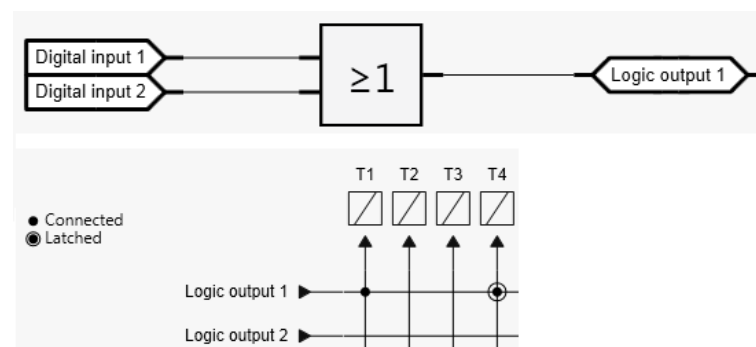

**Figure 5.13:** Virtual inputs and outputs can be assigned, latched or unlatched directly to inputs/outputs or logical operators.

### Virtual input

The virtual inputs can be viewed, named and controlled in the **Virtual inputs** setting view.

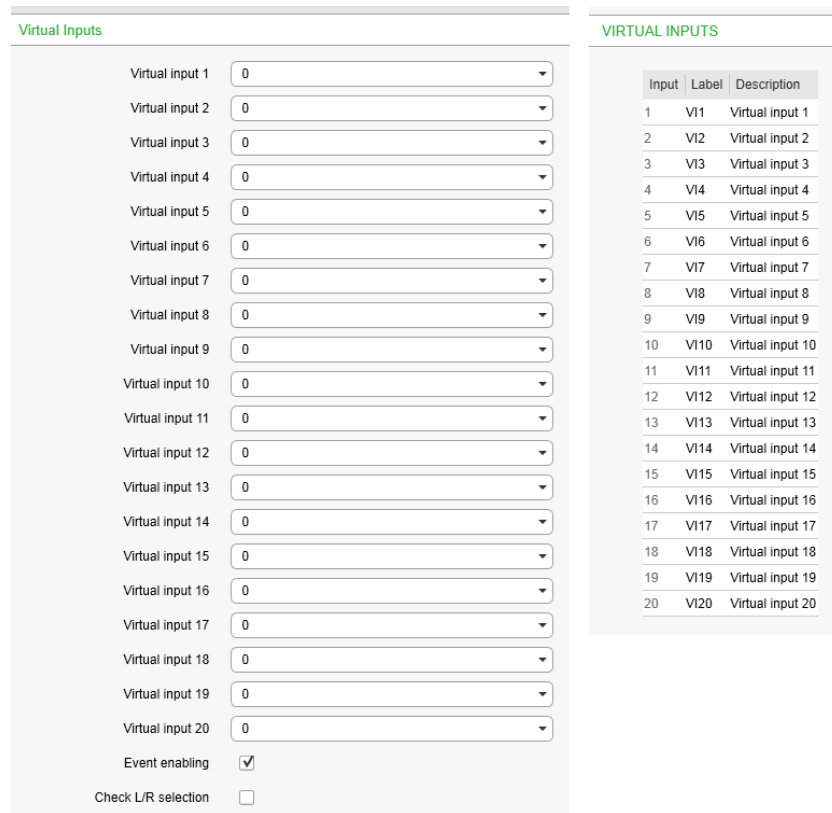

Figure 5.14: Virtual inputs setting view

Table 5.4: Parameters of virtual inputs

Parameter	Value	Unit	Description	Set
VI1-VI20	0 1		Status of virtual input	
Events	On Off		Event enabling	Set
<b>NAMES for VIRTUAL INPUTS (editable with Easergy Pro only)</b>				
Label	String of max. 10 characters		Short name for VIs on the local display Default is "VI n", n = 1–20	Set
Description	String of max. 32 characters		Long name for VIs. Default is "Virtual input n", n = 1–20	Set

Set = An editable parameter (password needed).

### Virtual output

In Easergy Pro, the **Virtual outputs** setting view is located **Inputs/Outputs** view.

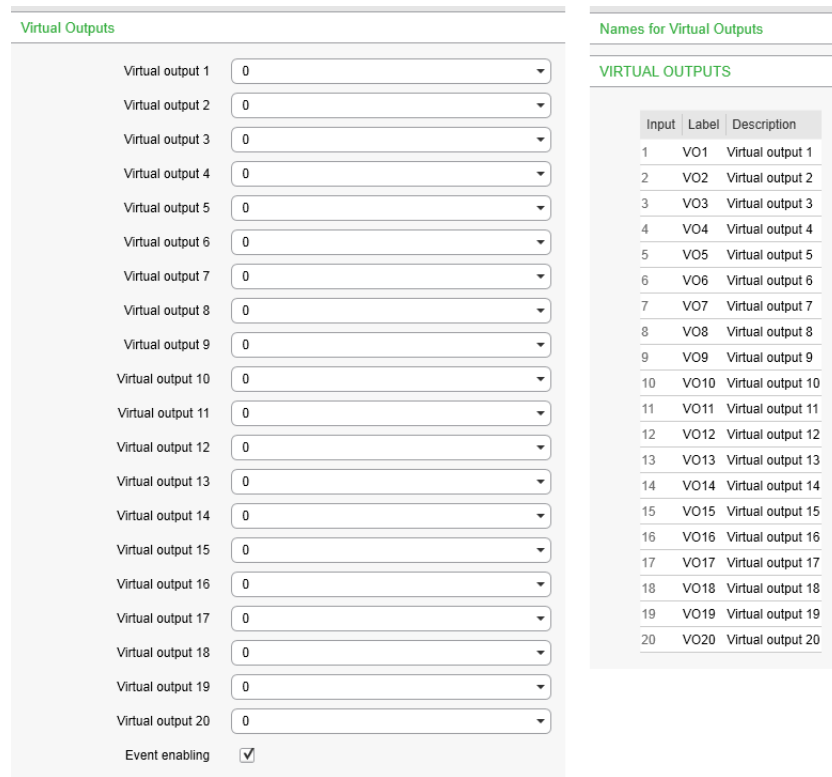

Figure 5.15: *Virtual outputs* setting view

Table 5.5: *Parameters of virtual outputs*

Parameter	Value	Unit	Description	Set
VO1-VO20	0 1		Status of virtual output	F
Events	On Off		Event enabling	Set
<b>NAMES for VIRTUAL OUTPUTS (editable with Easergy Pro only)</b>				
Label	String of max. 10 characters		Short name for VOs on the local display Default is "VOn", n=1-20	Set
Description	String of max. 32 characters		Long name for VOs. Default is "Virtual output n", n=1-20	Set

Set = An editable parameter (password needed). F = Editable when force flag is on.



## 5.4 Matrix

The relay has several matrices that are used for configuring the relay:

- **Output matrix**  
used to link protection stage signals, digital inputs, virtual inputs, function buttons, object control, logic output, relay's internal alarms, GOOSE signals and release latch signals to outputs, disturbance recorder trig input and virtual outputs
- **Block matrix**  
used to block protection stages
- **LED matrix**  
used to control LEDs on the front panel
- **Object block matrix**  
used to inhibit object control
- **Arc matrix**  
used to control current and light signals to arc stages and arc stages to the high-speed outputs

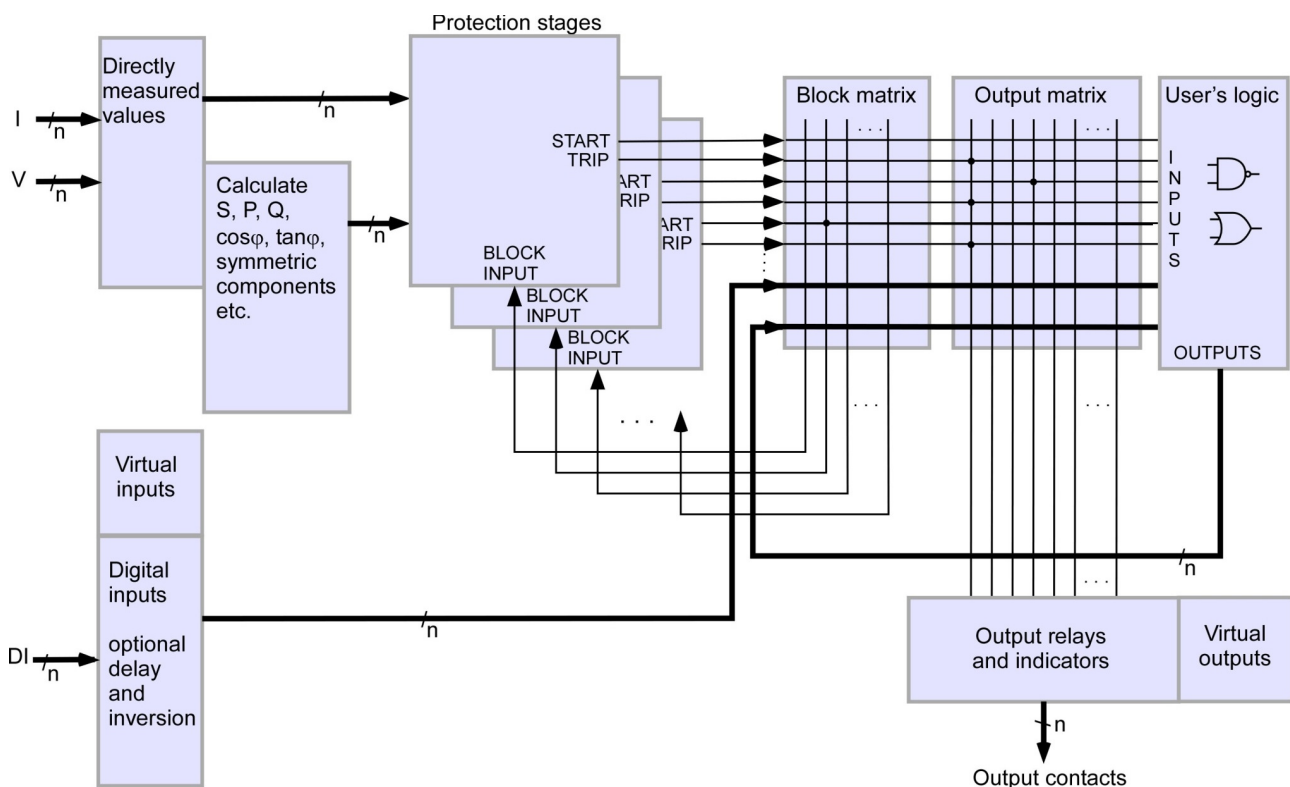

Figure 5.16: Blocking matrix and output matrix

**NOTE:** Blocking matrix can not be used to block the arc protection stages.

## 5.4.1 Output matrix

With the output matrix, the output signals of the various protection stages, digital inputs, logic outputs and other internal signals can be connected to the digital outputs, virtual outputs and so on.

**NOTE:** For configuring the high-speed operations of the arc protection, use the **Arc matrix – output** view. The configuration also becomes visible in the output matrix. The output matrix shows the status of the FPGA-driven outputs whereas the other electro-mechanical outputs can also be configured in the output matrix.

There are general-purpose LED indicators – "A", "B", "C" to "N" – available for customer-specific indications on the front panel. Their usage is define in a separate LED MATRIX.

There are two LED indicators specified for keys F1 and F2. The triggering of the disturbance recorder (DR) and virtual outputs are configurable in the output matrix.

A digital output or indicator LED can be configured as latched or non-latched. A non-latched relay follows the controlling signal. A latched relay remains activated although the controlling signal releases.

There is a common "release all latches" signal to release all the latched relays. This release signal resets all the latched digital outputs and indicators. The reset signal can be given via a digital input, via front panel or remotely through communication. Chapter 5.5 Releasing latches describes releasing latches procedure.

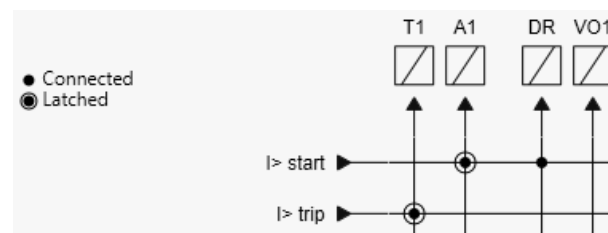

Figure 5.17: Trip and alarm relays together with virtual outputs can be assigned in output matrix. Also automatic triggering of disturbance recorder is done in output matrix.

## 5.4.2 Blocking matrix

By means of a blocking matrix, the operation of any protection stage (except the arc protection stages) can be blocked. The blocking signal can originate from the digital inputs or it can be a start or trip signal from a protection stage or an output signal from the user's programmable logic. In the Figure 5.16, an active blocking is indicated with a black dot (•) in the crossing point of a blocking signal and the signal to be blocked.

The maximum amount of stages to be blocked is 32.

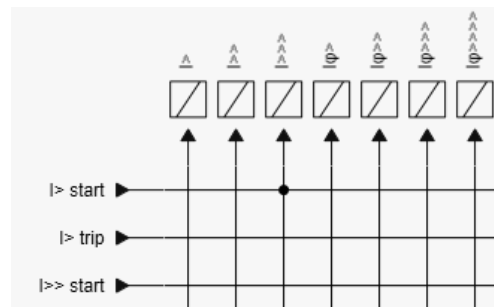

Figure 5.18: All protection stages (except Arc stages) can be blocked in block matrix.

The Blocked status becomes visible only when the stage is about to activate.

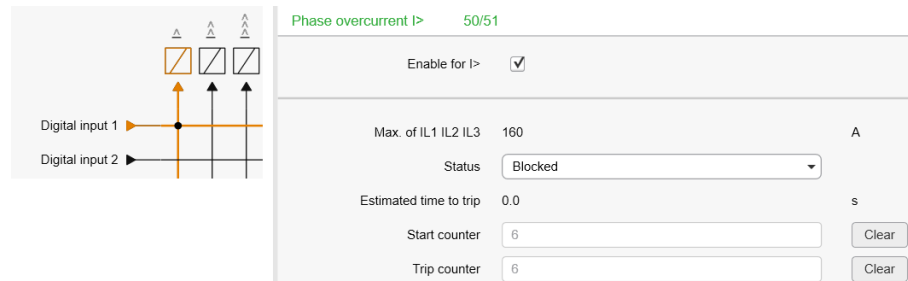

Figure 5.19: A view from the setting tool showing a DI input blocking connection (left picture) and the result for the I> stage when the DI is active and the stage exceeds its current start value.

### NOTICE

#### RISK OF NUISANCE TRIPPING

- The blocking matrix is dynamically controlled by selecting and deselecting protection stages.
- Activate the protection stages first, then store the settings in a relay. After that, refresh the blocking matrix before configuring it.

**Failure to follow these instructions can result in unwanted shutdown of the electrical installation.**

### 5.4.3 LED matrix

The LED matrix is used to link digital inputs, virtual inputs, function buttons, protection stage outputs, object statuses, logic outputs, alarm signals and GOOSE signals to various LEDs located on the front panel.

In the **LED configuration** setting view, each LED has three checkboxes with which the behavior of the LED is configured.

LED configuration				
LED	Description	Latch	Blink	Store
LED A (green)	LED A (green)	<input checked="" type="checkbox"/>	<input type="checkbox"/>	<input checked="" type="checkbox"/>
LED A (red)	LED A (red)	<input type="checkbox"/>	<input checked="" type="checkbox"/>	<input type="checkbox"/>
LED B (green)	LED B (green)	<input checked="" type="checkbox"/>	<input checked="" type="checkbox"/>	<input type="checkbox"/>
LED B (red)	LED B (red)	<input type="checkbox"/>	<input type="checkbox"/>	<input type="checkbox"/>
LED C (green)	LED C (green)	<input checked="" type="checkbox"/>	<input type="checkbox"/>	<input type="checkbox"/>
LED C (red)	LED C (red)	<input type="checkbox"/>	<input type="checkbox"/>	<input type="checkbox"/>
LED D (green)	LED D (green)	<input checked="" type="checkbox"/>	<input type="checkbox"/>	<input type="checkbox"/>

Figure 5.20: LED configuration

LEDs are assigned to control signals in the **LED matrix** setting view. It is not possible to control LEDs directly with logics.

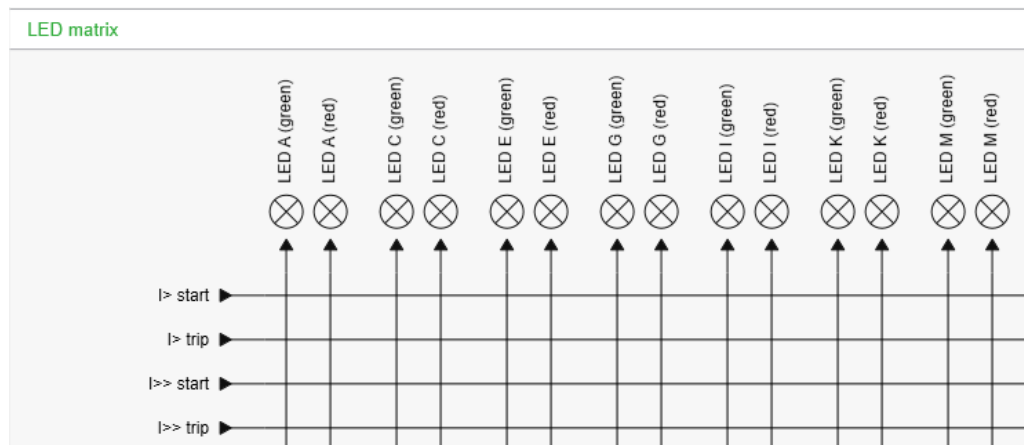

Figure 5.21: LED matrix

#### Normal setting

With no checkboxes selected, the assigned LED is active when the control signal is active. After deactivation, the LED turns off. LED activation and deactivation delay when controlled is approximately 10 ms.

### Latch setting

A latched LED activates when the control signal activates but remains active when the control signal deactivates. Latched LEDs are released using the procedure described in Chapter 5.5 Releasing latches.

### Blink setting

When the **Blink** setting is selected, the LED blinks when it is active.

### Store setting

To use the **Store** setting, the **Latch** setting must also be selected. The **Store** setting means that the latched state is retained after a restart.

### Inputs for LEDs

Inputs for LEDs can be assigned in the LED matrix. All 14 LEDs can be assigned as green or red. The connection can be normal, latched or blink-latched. In addition to protection stages, there are lots of functions that can be assigned to output LEDs. See Table 5.6.

**Table 5.6: Inputs for LEDs A-N**

Input	LED mapping	Latch	Description	Note
Protection, Arc and program-mable stages	LED A–N green or red	Normal/ Latched/ BlinkLatch	Different type of protection stages can be assigned to LEDs	Set
Digital/Virtual inputs and function buttons	LED A–N green or red	Normal/ Latched/ BlinkLatch	All different type of inputs can be assigned to LEDs	Set
Object open/close, object final trip and object failure information	LED A–N green or red	Normal/ Latched/ BlinkLatch	Information related to objects and object control	Set
Local control enabled	LED A–N green or red	Normal/ Latched/ BlinkLatch	While remote/local state is selected as local the “local control enabled” is active	Set
Logic output 1–20	LED A–N green or red	Normal/ Latched/ BlinkLatch	All logic outputs can be assigned to LEDs at the LED matrix	Set
Manual control indication	LED A–N green or red	Normal/ Latched/ BlinkLatch	When the user has controlled the objectives	Set
COM 1–5 comm.	LED A–N green or red	Normal/ Latched/ BlinkLatch	When the communication port 1 - 5 is active	Set
Setting error, seldiag alarm, pwd open and setting change	LED A–N green or red	Normal/ Latched/ BlinkLatch	Self diagnostic signal	Set
GOOSE NI1–64	LED A–N green or red	Normal/ Latched/ BlinkLatch	IEC 61850 goose communication signal	Set

Input	LED mapping	Latch	Description	Note
GOOSEERR1–16	LED A–N green or red	Normal/ Latched/ BlinkLatch	IEC 61850 goose communication signal	Set

### 5.4.4 Object block matrix

The object block matrix is used to link digital inputs, virtual inputs, function buttons, protection stage outputs, logic outputs, alarm signals and GOOSE signals to inhibit the control of objects, that is, circuit breakers, isolators and earthing switches.

Typical signals to inhibit controlling of the objects like circuit breaker are:

- protection stage activation
- statuses of other objects
- interlocking made with logic
- GOOSE signals

These and other signals are linked to objects in the object block matrix.

There are also event-type signals that do not block objects as they are on only for a short time, for example "Object1" open and "Object1 close" signals.

## 5.5 Releasing latches

### 5.5.1 Releasing latches using Easergy Pro

Go to **General > Release latches** and select **Release** from the **Release latches** drop-down menu.

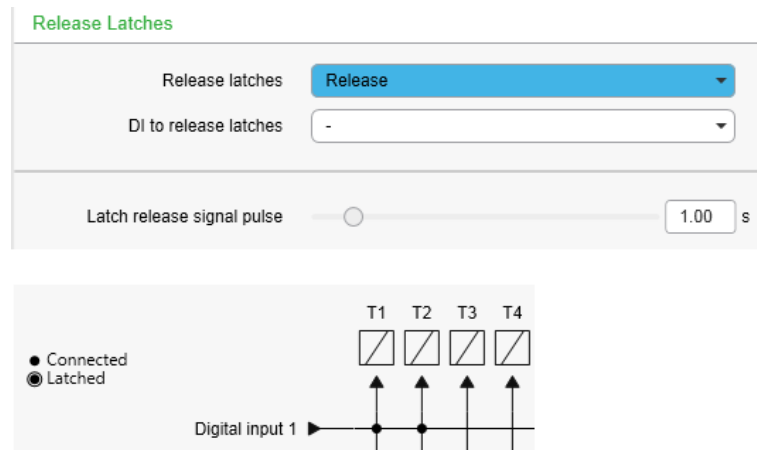





Figure 5.22: Latched output matrix signals released by using Easergy Pro setting tool.

### 5.5.2 Releasing latches using buttons and local panel display

Prerequisite: You have entered the correct password.

1. Press .
2. Press .
3. Select "Release" and press .

### 5.5.3 Releasing latches using F1 or F2 buttons

You can use the function buttons F1 or F2 to release all latches after configuring this function in Easergy Pro. You can make the configuration either under **GENERAL > RELEASE LATCHES** or under **INPUTS/OUTPUTS > FUNCTION BUTTONS**

To configure F1 to release latches under **GENERAL > RELEASE LATCHES**:

1. In Easergy Pro, go to **GENERAL > RELEASE LATCHES**.
2. Under **RELEASE LATCHES** select F1 from the **DI to release latches** drop-down menu.
3. Set 1 s delay for **Latch release signal pulse**.

**RELEASE LATCHES**

Release latches: -

DI to release latches: F1

Latch release signal pulse: 1.00 s

After this, pressing the F1 button on the relay's front panel releases all latches.

To configure F1 to release latches under **Inputs/Outputs > Function buttons**:

1. Under **Function buttons**, for F1, select PrgFncls from the **Selected control** drop down menu.
2. Set 1 s delay for **F1 pulse length**.
3. Under **Programmable functions for F1**, select "On" from the **Release all latches** drop-down menu.

**FUNCTION BUTTONS**

Button	State	Selected control	Selected Object
F1	0	PrgFncls	-
F2	0	F2	-

F1 pulse length (0=infinite): 1.00 s

F2 pulse length (0=infinite): 0.00 s

**Programmable functions for F1**

Release all latches: On

Clear I/O units' registers: Off

Install arc sensors & I/O units: Off

After this, pressing the F1 button on the relay's front panel releases all latches.

**NOTE:** The latch release signal can be activated only if the latched output is active.



## 5.6 Controllable objects

The relay allows controlling six objects, that is, circuit breakers, disconnectors and earthing switches by the "select before operate" or "direct control" principle.

The object block matrix and logic functions can be used to configure interlocking for a safe controlling before the output pulse is issued. The objects 1–6 are controllable while the objects 7–8 are only able to show the status.

Controlling is possible in the following ways:

- through the object control buttons
- through the front panel and display using a single-line diagram
- through the function keys
- through a digital input
- through a remote communication
- through Easergy Pro setting tool
- through Web server
- through Smart APP

The connection of an object to specific controlling outputs is done via an output matrix (object 1–6 open output, object 1–6 close output). There is also an output signal "Object failed" that is activated if the control of an object is not completed.

### Object states

Each object has the following states:

Setting	Value	Description
Object state	Undefined (00)	Actual state of the object
	Open	
	Close	
	Undefined (11)	

### Basic settings for controllable objects

Each controllable object has the following settings:

Setting	Value	Description
DI for 'obj open'	None, any digital input, virtual input or virtual output	Open information
DI for 'obj close'		Close information
DI for 'obj ready'		Ready information
Max ctrl pulse length	0.02 – 600 s	Pulse length for open and close commands. Control pulse stops once object changes its state

Setting	Value	Description
Completion timeout	0.02 – 600 s	Timeout of ready indication
Object control	Open/Close	Direct object control

If changing the states takes longer than the time defined by the “Max ctrl pulse length” setting, the object is inoperative and the “Object failure” matrix signal is set. Also, an undefined event is generated. “Completion timeout” is only used for the ready indication. If “DI for ‘obj ready’” is not set, the completion timeout has no meaning.

### Output signals of controllable objects

Each controllable object has 2 control signals in matrix:

Output signal	Description
Object x Open	Open control signal for the object
Object x Close	Close control signal for the object

These signals send control pulse when an object is controlled by digital input, remote bus, auto-reclose etc.

### Settings for read-only objects

Each read-only object has the following settings:

Setting	Vale	Description
DI for ‘obj open’	None, any digital input, virtual input or virtual output	Open information
DI for ‘obj close’		Close information
Object timeout	0.02 – 600 s	Timeout for state changes

If changing states takes longer than the time defined by “Object timeout” setting, and “Object failure” matrix signal is set. Also undefined-event is generated.

## 5.6.1

### Object control with digital inputs

Objects can be controlled with digital inputs, virtual inputs or virtual outputs. There are four settings for each controllable object:

Setting	Active
DI for remote open / close control	In remote state
DI for local open / close control	In local state

If the relay is in local control state, the remote control inputs are ignored and vice versa. An object is controlled when a rising edge is detected from the selected input. The length of digital input pulse should be at least 60 ms.

## 5.6.2 Local or remote selection

In local mode, digital outputs can be controlled via the front panel but they cannot be controlled via a remote serial communication interface.

In remote mode, digital outputs cannot be controlled via a front panel but they can be controlled via a remote serial communication interface.

The local or remote mode can be selected by using the front panel or via one selectable digital input. The digital input is normally used to change a whole station to local or remote mode. You can select the L/R digital input in the **Objects** setting view in Easergy Pro.

**Table 5.7: Local or remote selection**



Action	Control through Easergy Pro or SmartApp		Control through communication protocol	
	Local	Remote	Local	Remote
Local/Remote switch status				
CB control	Yes	No	No	Yes
Setting or configuration changes	Yes	Yes	Yes	Yes
Communication configuration	Yes	Yes	Yes	Yes
Virtual inputs <sup>1)</sup>	Yes	No	No	Yes

1) Virtual inputs have a general parameter "Check L/R selection" for disabling the L/R check.

## 5.6.3 Object control with I and O buttons

The relay also has dedicated control buttons for objects. (I) stands for object closing and (O) controls object open command internally. Control buttons are configured in the OBJECTS view.



**Table 5.8: Parameters of function keys**

Parameter	Value	Unit	Description	Set
Disabled Object 1 – 6	- Obj1 – Obj6		 Button closes selected object if password is enabled   Button opens selected object if password is enabled	Set
Mode for control buttons	Selective Direct		Control operation needs confirmation (select-execute) Control operation is done without confirmation	

## 5.6.4 Object control with F1 and F2

Objects can be controlled with the function buttons F1 and F2. By default, the F1 and F2 buttons are configured to control F1 and F2 variables that can further be assigned to control objects.

**Table 5.9: Parameters of F1 and F2**

Parameter	Value	State	Pulse length <sup>*)</sup>	Description
F1	F1, V1-V20, ObjCtrl	0.1	0600 s	 controls F1, V1-V20 or ObjCtrl parameters.
F2	F2, V1-V20, ObjCtrl	0.1	0-600 s	 controls F2, V1-V20 and ObjCtrl parameters.

<sup>\*)</sup> Pulse length applies to values F1 and F2 only

You can configure the button functions in the **Inputs/outputs > Function buttons** setting view in Easergy Pro.

Function buttons

Button	State	Selected control	Selected Object
F1	0	ObjCtrl	2 LocOpen
F2	0	F2	-

Figure 5.23: Function buttons setting view

If **ObjCtrl** has been selected under **Selected control**, the selected object is shown under **Selected object**. Otherwise, this column is empty.

When selecting **ObjCtrl**, link the function button to the appropriate object in the **General > Objects** setting view.

**CTRL OBJECT 2**

Label(Obj2)	<input type="text" value="Obj2"/>
Obj2 state	Open
Obj2 final trip by	-
DI for 'obj open'	<input type="text" value="-"/>
DI for 'obj closed'	<input type="text" value="-"/>
DI for 'obj ready'	<input type="text" value="-"/>
Max ctrl pulse length	<input type="text" value="0.20"/> s
Completion timeout	<input type="text" value="10.00"/> s
Object 2 control	<input type="button" value="Open"/> <input type="button" value="Close"/>
DI for remote open ctr	<input type="text" value="-"/>
DI for remote close ctr	<input type="text" value="-"/>
DI for local open ctr	<input type="text" value="F1"/>
DI for local close ctr	<input type="text" value="F2"/>
Inactivity days limit	<input type="text" value="500"/>
Last state change	-

Figure 5.24: Ctrl object 2 setting view

# 5.7 Logic functions

The relay supports customer-defined programmable logic for boolean signals. User-configurable logic can be used to create something that is not provided by the relay as a default. You can see and modify the logic in the **General > Logic** setting view in the Easergy Pro setting tool.

**Table 5.10: Available logic functions and their memory use**

Logic functions	No. of gates reserved	Max. no. of input gates	Max. no. of logic outputs
AND	1	32 (An input gate can include any number of inputs.)	20
OR	1		
XOR	1		
AND+OR	2		
CT (count+reset)	2		
INVAND	2		
INVOR	2		
OR+AND	2		
RS (set+reset)	2		
RS_D (set+D+load+reset)	4		

The consumed memory is dynamically shown on the configuration view in percentage. The first value indicates the memory consumption of inputs, the second value the memory consumption of gates and the third value the memory consumption of outputs. The logic is operational as long the memory consumption of the inputs, gates or outputs remains individually below or equal to 100 %.

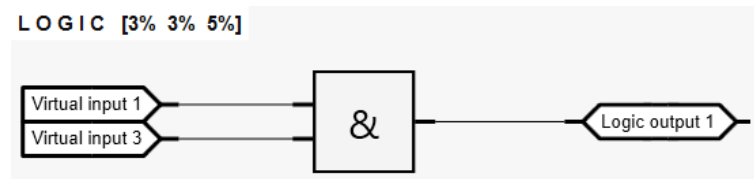
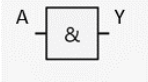
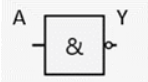
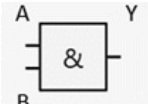
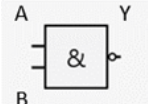
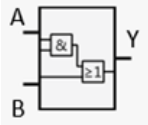
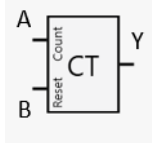
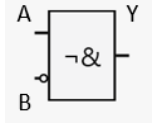
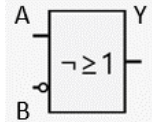

Figure 5.25: Logic and memory consumption

**Truth tables**

**Table 5.11: Truth table**

Gate	Symbol	Truth table																		
AND		<table border="1"> <thead> <tr> <th colspan="2">In</th> <th>Out</th> </tr> <tr> <th>A</th> <th>B</th> <th>Y</th> </tr> </thead> <tbody> <tr> <td>0</td> <td>0</td> <td>0</td> </tr> <tr> <td>1</td> <td>1</td> <td>1</td> </tr> </tbody> </table>	In		Out	A	B	Y	0	0	0	1	1	1						
	In		Out																	
	A	B	Y																	
	0	0	0																	
1	1	1																		
	<table border="1"> <thead> <tr> <th colspan="2">In</th> <th>Out</th> </tr> <tr> <th>A</th> <th>B</th> <th>Y</th> </tr> </thead> <tbody> <tr> <td>0</td> <td>0</td> <td>1</td> </tr> <tr> <td>1</td> <td>0</td> <td>0</td> </tr> </tbody> </table>	In		Out	A	B	Y	0	0	1	1	0	0							
In		Out																		
A	B	Y																		
0	0	1																		
1	0	0																		
	<table border="1"> <thead> <tr> <th colspan="2">In</th> <th>Out</th> </tr> <tr> <th>A</th> <th>B</th> <th>Y</th> </tr> </thead> <tbody> <tr> <td>0</td> <td>0</td> <td>0</td> </tr> <tr> <td>1</td> <td>1</td> <td>1</td> </tr> <tr> <td>1</td> <td>0</td> <td>0</td> </tr> <tr> <td>0</td> <td>1</td> <td>0</td> </tr> </tbody> </table>	In		Out	A	B	Y	0	0	0	1	1	1	1	0	0	0	1	0	
In		Out																		
A	B	Y																		
0	0	0																		
1	1	1																		
1	0	0																		
0	1	0																		
	<table border="1"> <thead> <tr> <th colspan="2">In</th> <th>Out</th> </tr> <tr> <th>A</th> <th>B</th> <th>Y</th> </tr> </thead> <tbody> <tr> <td>0</td> <td>0</td> <td>1</td> </tr> <tr> <td>1</td> <td>1</td> <td>0</td> </tr> <tr> <td>1</td> <td>0</td> <td>1</td> </tr> <tr> <td>0</td> <td>1</td> <td>1</td> </tr> </tbody> </table>	In		Out	A	B	Y	0	0	1	1	1	0	1	0	1	0	1	1	
In		Out																		
A	B	Y																		
0	0	1																		
1	1	0																		
1	0	1																		
0	1	1																		
AND+OR		<table border="1"> <thead> <tr> <th colspan="2">In</th> <th>Out</th> </tr> <tr> <th>A</th> <th>B</th> <th>Y</th> </tr> </thead> <tbody> <tr> <td>0</td> <td>0</td> <td>0</td> </tr> <tr> <td>1</td> <td>1</td> <td>1</td> </tr> <tr> <td>1</td> <td>0</td> <td>1</td> </tr> <tr> <td>0</td> <td>1</td> <td>1</td> </tr> </tbody> </table>	In		Out	A	B	Y	0	0	0	1	1	1	1	0	1	0	1	1
In		Out																		
A	B	Y																		
0	0	0																		
1	1	1																		
1	0	1																		
0	1	1																		

Gate	Symbol	Truth table																												
CT (count+reset)		<table border="1"> <thead> <tr> <th colspan="2">In</th> <th colspan="2">Out</th> </tr> <tr> <th>A</th> <th>B</th> <th>Y</th> <th>Y</th> </tr> <tr> <th>Cont</th> <th>Reset</th> <th>Setting</th> <th>New</th> </tr> </thead> <tbody> <tr> <td>1</td> <td></td> <td>3</td> <td>0</td> </tr> <tr> <td>1</td> <td></td> <td>3</td> <td>0</td> </tr> <tr> <td>1</td> <td></td> <td>3</td> <td>1</td> </tr> <tr> <td></td> <td>1</td> <td>3</td> <td>0</td> </tr> </tbody> </table>	In		Out		A	B	Y	Y	Cont	Reset	Setting	New	1		3	0	1		3	0	1		3	1		1	3	0
In		Out																												
A	B	Y	Y																											
Cont	Reset	Setting	New																											
1		3	0																											
1		3	0																											
1		3	1																											
	1	3	0																											
INVAND		<table border="1"> <thead> <tr> <th colspan="2">In</th> <th>Out</th> </tr> <tr> <th>A</th> <th>B</th> <th>Y</th> </tr> </thead> <tbody> <tr> <td>0</td> <td>0</td> <td>0</td> </tr> <tr> <td>1</td> <td>0</td> <td>1</td> </tr> <tr> <td>1</td> <td>1</td> <td>0</td> </tr> <tr> <td>0</td> <td>1</td> <td>0</td> </tr> </tbody> </table>	In		Out	A	B	Y	0	0	0	1	0	1	1	1	0	0	1	0										
In		Out																												
A	B	Y																												
0	0	0																												
1	0	1																												
1	1	0																												
0	1	0																												
INVOR		<table border="1"> <thead> <tr> <th colspan="2">In</th> <th>Out</th> </tr> <tr> <th>A</th> <th>B</th> <th>Y</th> </tr> </thead> <tbody> <tr> <td>0</td> <td>0</td> <td>1</td> </tr> <tr> <td>1</td> <td>1</td> <td>1</td> </tr> <tr> <td>1</td> <td>0</td> <td>1</td> </tr> <tr> <td>0</td> <td>1</td> <td>0</td> </tr> </tbody> </table>	In		Out	A	B	Y	0	0	1	1	1	1	1	0	1	0	1	0										
In		Out																												
A	B	Y																												
0	0	1																												
1	1	1																												
1	0	1																												
0	1	0																												

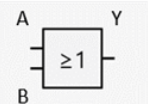
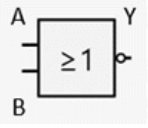
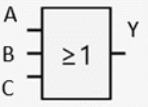
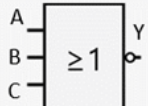
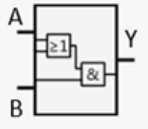

Gate	Symbol	Truth table																											
OR		<table border="1"> <thead> <tr> <th colspan="2">In</th> <th>Out</th> </tr> <tr> <th>A</th> <th>B</th> <th>Y</th> </tr> </thead> <tbody> <tr> <td>0</td> <td>0</td> <td>0</td> </tr> <tr> <td>1</td> <td>1</td> <td>1</td> </tr> <tr> <td>1</td> <td>0</td> <td>1</td> </tr> <tr> <td>0</td> <td>1</td> <td>1</td> </tr> </tbody> </table>	In		Out	A	B	Y	0	0	0	1	1	1	1	0	1	0	1	1									
	In		Out																										
	A	B	Y																										
	0	0	0																										
1	1	1																											
1	0	1																											
0	1	1																											
	<table border="1"> <thead> <tr> <th colspan="2">In</th> <th>Out</th> </tr> <tr> <th>A</th> <th>B</th> <th>Y</th> </tr> </thead> <tbody> <tr> <td>0</td> <td>0</td> <td>1</td> </tr> <tr> <td>1</td> <td>1</td> <td>0</td> </tr> <tr> <td>1</td> <td>0</td> <td>0</td> </tr> <tr> <td>0</td> <td>1</td> <td>0</td> </tr> </tbody> </table>	In		Out	A	B	Y	0	0	1	1	1	0	1	0	0	0	1	0										
In		Out																											
A	B	Y																											
0	0	1																											
1	1	0																											
1	0	0																											
0	1	0																											
	<table border="1"> <thead> <tr> <th colspan="3">In</th> <th>Out</th> </tr> <tr> <th>A</th> <th>B</th> <th>C</th> <th>Y</th> </tr> </thead> <tbody> <tr> <td>0</td> <td>0</td> <td>0</td> <td>0</td> </tr> <tr> <td>1</td> <td>0</td> <td>0</td> <td>1</td> </tr> <tr> <td>1</td> <td>1</td> <td>0</td> <td>1</td> </tr> <tr> <td>0</td> <td>1</td> <td>0</td> <td>1</td> </tr> <tr> <td>1</td> <td>1</td> <td>1</td> <td>1</td> </tr> </tbody> </table>	In			Out	A	B	C	Y	0	0	0	0	1	0	0	1	1	1	0	1	0	1	0	1	1	1	1	1
In			Out																										
A	B	C	Y																										
0	0	0	0																										
1	0	0	1																										
1	1	0	1																										
0	1	0	1																										
1	1	1	1																										
	<table border="1"> <thead> <tr> <th colspan="3">In</th> <th>Out</th> </tr> <tr> <th>A</th> <th>B</th> <th>C</th> <th>Y</th> </tr> </thead> <tbody> <tr> <td>0</td> <td>0</td> <td>0</td> <td>1</td> </tr> <tr> <td>1</td> <td>0</td> <td>0</td> <td>0</td> </tr> <tr> <td>1</td> <td>1</td> <td>0</td> <td>0</td> </tr> <tr> <td>0</td> <td>1</td> <td>0</td> <td>0</td> </tr> <tr> <td>1</td> <td>1</td> <td>1</td> <td>0</td> </tr> </tbody> </table>	In			Out	A	B	C	Y	0	0	0	1	1	0	0	0	1	1	0	0	0	1	0	0	1	1	1	0
In			Out																										
A	B	C	Y																										
0	0	0	1																										
1	0	0	0																										
1	1	0	0																										
0	1	0	0																										
1	1	1	0																										
OR+AND		<table border="1"> <thead> <tr> <th colspan="2">In</th> <th>Out</th> </tr> <tr> <th>A</th> <th>B</th> <th>Y</th> </tr> </thead> <tbody> <tr> <td>0</td> <td>0</td> <td>0</td> </tr> <tr> <td>1</td> <td>1</td> <td>1</td> </tr> <tr> <td>1</td> <td>0</td> <td>0</td> </tr> <tr> <td>0</td> <td>1</td> <td>0</td> </tr> </tbody> </table>	In		Out	A	B	Y	0	0	0	1	1	1	1	0	0	0	1	0									
In		Out																											
A	B	Y																											
0	0	0																											
1	1	1																											
1	0	0																											
0	1	0																											

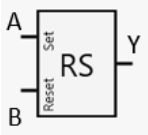
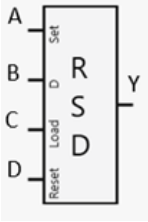
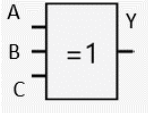
Gate	Symbol	Truth table																																								
RS (set+reset)		<table border="1"> <thead> <tr> <th>A</th> <th>B</th> <th>Y</th> </tr> </thead> <tbody> <tr> <td>Set</td> <td>Reset</td> <td>Y</td> </tr> <tr> <td>1</td> <td>0</td> <td>1</td> </tr> <tr> <td>1</td> <td>1</td> <td>0</td> </tr> <tr> <td>0</td> <td>0</td> <td>0</td> </tr> <tr> <td>0</td> <td>1</td> <td>0</td> </tr> </tbody> </table>	A	B	Y	Set	Reset	Y	1	0	1	1	1	0	0	0	0	0	1	0																						
A	B	Y																																								
Set	Reset	Y																																								
1	0	1																																								
1	1	0																																								
0	0	0																																								
0	1	0																																								
RS_D (set+D+load+reset)		<table border="1"> <thead> <tr> <th>A</th> <th>B</th> <th>C</th> <th>D</th> <th>Y</th> </tr> <tr> <th>Set</th> <th>D</th> <th>Load</th> <th>Reset</th> <th>State</th> </tr> </thead> <tbody> <tr> <td>0</td> <td>0</td> <td>0</td> <td>0</td> <td>0<sup>*)</sup></td> </tr> <tr> <td>1</td> <td>X</td> <td>X</td> <td>0</td> <td>1</td> </tr> <tr> <td>1</td> <td>X</td> <td>X</td> <td>1</td> <td>0</td> </tr> <tr> <td>0</td> <td>1</td> <td>0</td> <td>0</td> <td>0</td> </tr> <tr> <td>0</td> <td>1</td> <td>1</td> <td>0</td> <td>1</td> </tr> <tr> <td>0</td> <td>1</td> <td>1</td> <td>1</td> <td>0<sup>**)</sup></td> </tr> </tbody> </table> <p>X = Any state</p> <p><sup>*)</sup> Initial state</p> <p><sup>**)</sup> The state remains 1 until Reset is set active</p> <p>If Set or D + Load are high, the state returns to high if Reset returns to low.</p>	A	B	C	D	Y	Set	D	Load	Reset	State	0	0	0	0	0 <sup>*)</sup>	1	X	X	0	1	1	X	X	1	0	0	1	0	0	0	0	1	1	0	1	0	1	1	1	0 <sup>**)</sup>
A	B	C	D	Y																																						
Set	D	Load	Reset	State																																						
0	0	0	0	0 <sup>*)</sup>																																						
1	X	X	0	1																																						
1	X	X	1	0																																						
0	1	0	0	0																																						
0	1	1	0	1																																						
0	1	1	1	0 <sup>**)</sup>																																						
XOR		<table border="1"> <thead> <tr> <th colspan="3">In</th> <th>Out</th> </tr> <tr> <th>A</th> <th>B</th> <th>C</th> <th>Y</th> </tr> </thead> <tbody> <tr> <td>0</td> <td>0</td> <td>0</td> <td>0</td> </tr> <tr> <td>0</td> <td>0</td> <td>1</td> <td>1</td> </tr> <tr> <td>0</td> <td>1</td> <td>0</td> <td>1</td> </tr> <tr> <td>0</td> <td>1</td> <td>1</td> <td>0</td> </tr> <tr> <td>1</td> <td>0</td> <td>0</td> <td>1</td> </tr> <tr> <td>1</td> <td>0</td> <td>1</td> <td>0</td> </tr> <tr> <td>1</td> <td>1</td> <td>0</td> <td>0</td> </tr> <tr> <td>1</td> <td>1</td> <td>1</td> <td>1</td> </tr> </tbody> </table>	In			Out	A	B	C	Y	0	0	0	0	0	0	1	1	0	1	0	1	0	1	1	0	1	0	0	1	1	0	1	0	1	1	0	0	1	1	1	1
In			Out																																							
A	B	C	Y																																							
0	0	0	0																																							
0	0	1	1																																							
0	1	0	1																																							
0	1	1	0																																							
1	0	0	1																																							
1	0	1	0																																							
1	1	0	0																																							
1	1	1	1																																							

**Logic element properties**

After you have selected the required logic gate in Easergy Pro, you can change the function of the gate in the **Element properties** window by clicking the gate.

**Element properties**

Type: INVAND

Inverted

ON delay: 0 ms

OFF delay: 0 ms

**Inputs**

Normal: - 1 +

Inverting: - 1 +

Figure 5.26: Logic element properties

The settings listed in Table 5.12 are available for the logical gates depending on the selected element.

Table 5.12: Logic element properties

Property	Description
<b>Element properties</b>	
Type	Change the logical function of the gate
Inverted	Inverts the output state of the logical gate
ON delay	Time delay to activate the output after logical conditions are met
OFF delay	Time delay for how long the gate remain active even the logical condition is reset
Count	Setting for counter (CT gate only)
Reverse	Use to reverse AND and OR gates (AND+OR gate only)
<b>Inputs</b>	
Normal - / +	Use to increase or decrease number of inputs
Inverting - / +	Use to increase or decrease number of inverted inputs. This setting is visible for INVAND and INVOR gates only
Count	Use to increase or decrease number of count inputs (CT gate only)
Reset	Use to increase or decrease number of count inputs (CT gate only)
AND	Use to increase or decrease number of inputs for AND gates (AND+OR gate only)
OR	Use to increase or decrease number of inputs for OR gates (AND+OR gate only)
Set	Use to increase or decrease number of Set inputs (RS_D gate only)
D	Use to increase or decrease number of Data inputs (RS_D gate only)
Load	Use to increase or decrease number of Load inputs (RS_D gate only)
Reset	Use to increase or decrease number of Reset inputs (RS_D gate only)

## 5.8 Local panel

Easergy P3M30 and P3M32 has one LCD matrix display.

All the main menus are located on the left side and to get in to certain submenu, move up and down the main menus.

```

I> STATUS          50/51 ▶
FL | Status        -
Evt. TripTime     0.0s
DR | SCntr         0
Runh TCntr        0
TIMR SetGrp       1
DI  | SGrp1DI      -
DO  | SGrp2DI      -
Arc  | SGrp3DI      -
Prot. SGrp4DI     DI1
I> | Force         Off
I>>
Io>
Io>>

```

Figure 5.27: The main menu locates on the left side of the display.

### 5.8.1 Mimic display

Easergy P3M30 and P3M32 has a mimic display enabled as a default. Mimic can be modified according to the application or disabled if not needed. The mimic display can be configured only by using Easergy Pro setting tool. Mimic cannot be created using the relay's front panel.

You can modify the local panel mimic in the **Mimic** that is located under the **Device menu** leaflet. The mimic menu has to be enabled in the **Local panel configuration**. Mimic cannot be enabled or disabled using the relay's local panel.

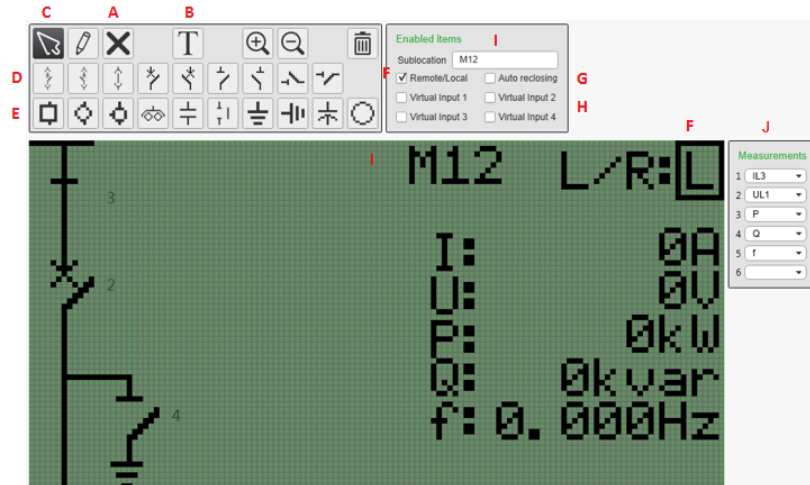

Figure 5.28: MIMIC menu setting view

- A) To clear an object or drawing, first point an empty square (B) with the mouse. Then point the object item with the mouse. The color of the object item turns red. To clear the whole mimic, click on the empty area.
- B) Text tool
- C) To move an existing drawing or object, point it with the mouse. The color turns green. Hold down the left mouse button and move the object.
- D) Different type of configurable objects. The object's number corresponds to the number in **General > Objects**.
- E) Some predefined drawings.
- F) The remote/local selection defines whether certain actions are granted or not. In remote state, it is not possible to locally enable or disable auto-reclosing or to control objects. The remote/local state can be changed in **General > Objects**.
- G) Creates auto-reclosing on/off selection to mimic.
- H) Creates virtual input activation on the local mimic display.
- I) Describes the relay's location. Text comes from the relay info menu.
- J) Up to six configurable measurements.

**Table 5.13: Mimic functionality**

Parameter	Value	Unit	Description	Set
Sublocation	Text field		Up to 9 characters. Fixed location.	Set
Object 1–8	1–8		Double-click on top of the object to change the control number between 1 and 8. Number 1 corresponds to object 1 in <b>General &gt; Objects</b> .	Set
Local / Remote mode	L R		Local / Remote control. R stands for remote. Remote local state can be changed in <b>General &gt; Objects</b> as well. Position can be changed.	Set
Auto-reclosure	0 1		Possible to enable/disable auto-reclosure locally in local mode (L) or remotely in remote mode (R). Position can be changed.	Set
Measurement display 1–6	IL1–IL3 IO U12, U23, U31, UL1, UL2, UL3, U0 f, P, Q, S, P.F. CosPhi E+, Eq+, E-, Eq- ARStart, ARFaill, ARShot1–5 IFLT Starts, Trips IOCalc IL1–IL3da, IL Pda, Qda, Sda T fSYNC, USYNC dIL1–dIL3 VAI1–VAI5 ExtAI1–6*		Up to 6 freely selectable measurements.	Set
Virtual input 1–4	0 1		Change the status of virtual inputs while the password is enabled. Position can be changed.	Set

Set = Settable.

\* Requires serial communication interface and External IO protocol activated.

**NOTE:**The measurement display data selection depends on the voltage measurement mode selected in the SCALING setting view.

## 5.8.2

### Local panel configuration

Information displayed on the measurement view is configured in **General > Local panel conf.**

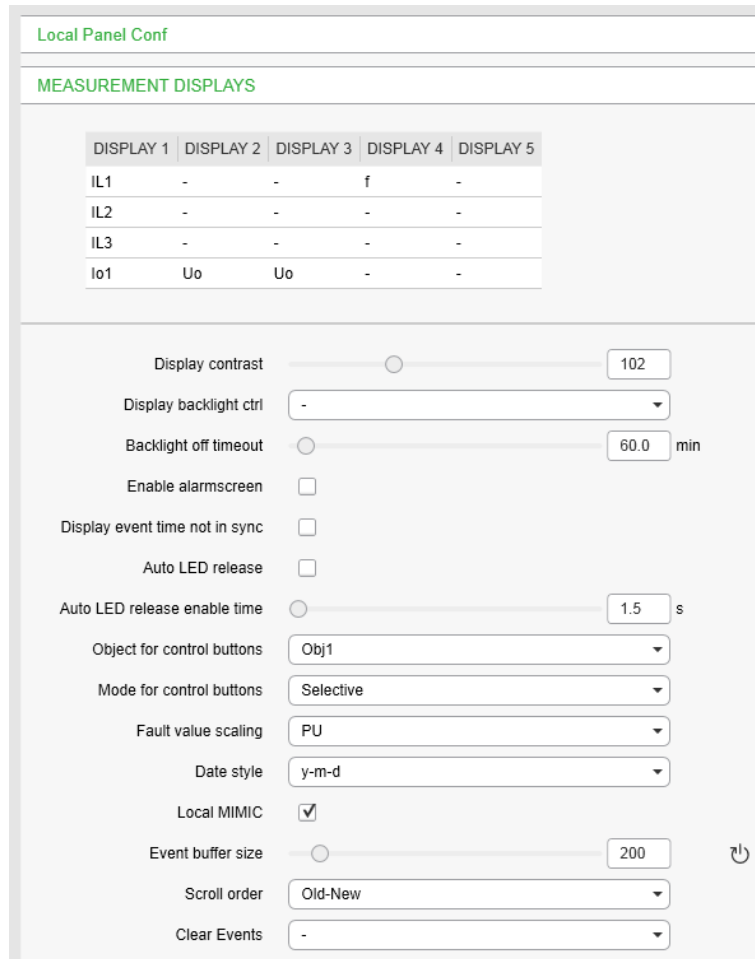

Figure 5.29: Local panel configuration menu

Table 5.14: Local panel configuration

Parameter	Value	Unit	Description	Set
Display 1–5	IL1–3 IO U12, U23, U31, UL1, UL2, UL3, U0 f, P, Q, S, P.F. CosPhi E+, Eq+, E-, Eq- ARStart, ARFaill, ARShot1–5 IFLT Starts, Trips IOCalc IL IL1–3da IL1–3 max IL1–3 min IL1–3daMax Pda, Qda, Sda T fSYNC, USYNC VAI1–5 ExtAI1–6* SetGrp		20 (5 x 4) freely configurable measurement values can be selected	Set **

Parameter	Value	Unit	Description	Set
Display contrast	50–210		Contrast can be changed in the relay menu as well.	Set
Display backlight control	DI1–44, Arc1–3, ArcF, BI, VI1–4, LED1–14, VO1–6		Activates the backlight of the display.	Set **
Backlight off timeout	0.0–2000.0	min	Configurable delay for backlight to turn off when the relay is not used. Default value is 60 minutes. When value is zero (0.0) backlight stays on all the time.	Set
Enable alarm screen	Checked Unchecked		Pop-up text box for events. pop-up events can be checked individually by pressing enter, but holding the button for 2 seconds checks all the events at once.	Set
AR info for mimic display	Checked Unchecked		Auto reclosure status visible on top of the local mimic display.	Set
Sync I info for mimic display	Checked Unchecked		Synchro-check status visible on top of the local mimic display. Operates together with auto-reclosure.	Set
Auto LED release	Checked Unchecked		Enables automatix LED release functionality.	Set
Auto LED release enable time	0.1–600	s	Default 1.5 s. When new LEDs are latched, the previous active latches are released automatically if the set time has passed.	Set
Fault value scaling	PU, Pri		Fault values per unit or primary sscaled.	Set
Local MIMIC	Checked Unchecked		Enable / disable the local mimic (enabled as default).	Set
Event buffer size	50–2000		Event buffer size. Default setting is 200 events.	Set ***

Set = Settable.

\* Requires serial communication interface and External IO protocol activated.

\*\* Inputs vary according to the relay type.

\*\*\* The existing events are lost if the event buffer size is changed.



## 6 Protection functions

Each protection stage can independently be enabled or disabled according to the requirements of the intended application.

### 6.1 Maximum number of protection stages in one application

The relay limits the maximum number of enabled protection stages to about 30. The exact number depends on the central processing unit's load consumption and available memory as well as the type of the stages.

The individual protection stage and total load status can be found in the **Protection > Protection stage status** setting view in the Easergy Pro setting tool.

### 6.2 General features of protection stages

#### Setting groups

Setting groups are controlled by using digital inputs, function keys or virtual inputs, via the front panel or custom logic. When none of the assigned inputs are active, the setting group is defined by the parameter 'SetGrp no control state'. When controlled input activates, the corresponding setting group is activated as well. If the control signal of the setting group is lost, the setting "Keep last" forces the last active group into use. If multiple inputs are active at the same time, the active setting group is defined by 'SetGrp priority'. By using virtual I/O, the active setting group can be controlled using the local panel display, any communication protocol or the inbuilt programmable logic functions. All protection stages have four setting groups.

Set group 1 DI control	DI1			
Set group 2 DI control	DI2			
Set group 3 DI control	DI3			
Set group 4 DI control	DI4			

Group	1			
	Group 1	Group 2	Group 3	Group 4
Pick-up setting [A]	200	2000	480	480
Pick-up setting [xImot]	0.50	5.00	1.20	1.20
Delay curve family	DT	DT	IEC	IEC
Delay type	DT	DT	NI	NI
Operation delay [s]	300.00	0.30	0.30	0.30
Inv. time coefficient k	1.00	1.00	1.00	1.00

## Example

Any digital input can be used to control setting groups but in this example, DI1, DI2, DI3 and DI4 are chosen to control setting groups 1 to 4. This setting is done with the parameter “Set group x DI control” where x refers to the desired setting group.

Set group 1 DI control	DI1			
Set group 2 DI control	DI2			
Set group 3 DI control	DI3			
Set group 4 DI control	DI4			

Group	2			
	Group 1	Group 2	Group 3	Group 4
Pick-up setting [A]	50	500	120	120
Pick-up setting [xIn]	0.50	5.00	1.20	1.20
Delay curve family	DT	DT	IEC	IEC
Delay type	DT	DT	NI	NI
Operation delay [s]	300.00	0.30	0.30	0.30
Inv. time coefficient k	1.00	1.00	1.00	1.00

Figure 6.1: DI1, DI2, DI3, DI4 are configured to control Groups 1 to 4 respectively.

Use the 'SetGrp common change' parameter to force all protection stages to group 1, 2, 3 or 4. The control becomes active if there is no local control in the protection stage. You can activate this parameter using Easergy Pro.

“SetGrp priority” is used to give a condition to a situation where two or more digital inputs, controlling setting groups, are active at the same time. SetGrp priority could have values “1 to 4” or “4 to 1”.

### Valid Protection Stages

Enabled stages	22
SetGrp common change	1
SetGrp no control state	1
SetGrp priority	1 to 4

Figure 6.2: SetGrp priority setting is located in the Valid Protection stages view.

Assuming that DI2 and DI3 are active at the same time and SetGrp priority is set to “1 to 4”, setting group 2 becomes active. If SetGrp priority is reversed, that is, set to “4 to 1”, the setting group 3 becomes active.

### Protection stage statuses

The status of a protection stage can be one of the followings:

- **Ok = '0'**  
The stage is idle and is measuring the analog quantity for the protection. No power system fault detected.
- **Blocked**  
The stage is detecting a fault but blocked by some reason.
- **Start**  
The stage is counting the operation delay.
- **Trip**  
The stage has tripped and the fault is still on.

The blocking reason may be an active signal via the block matrix from other stages, the programmable logic or any digital input. Some stages also have inbuilt blocking logic. For example an under frequency stage is blocked if voltage is too low. For more details about the block matrix, see Chapter 5.4.2 Blocking matrix.

### Protection stage counters

Each protection stage has start and trip counters that are incremented when the stage starts or trips. The start and trip counters are reset on relay reboot.

### Forcing start or trip condition for testing purposes

There is a "Forcing flag" parameter which, when activated, allows forcing the status of any protection stage to be "start" or "trip" for half a second. By using this forcing feature, current or voltage injection is not necessary to check the output matrix configuration, to check the wiring from the digital outputs to the circuit breaker and also to check that communication protocols are correctly transferring event information to a SCADA system.

After testing, the forcing flag is automatically reset five minutes after the last local panel push button activity.

The force flag also enables forcing the digital outputs and the optional mA outputs.

The force flag can be found in the Relays menu.

RELAYS

Trip relay 1	1
Trip relay 2	1
Trip relay 3	0
Trip relay 4	0
Trip relay 5	0
Trip relay 6	0
Trip relay 7	0
Signal relay 1	1
Service status output	0

Force flag

### Start and trip signals

Every protection stage has two internal binary output signals: start and trip. The start signal is issued when a fault has been detected. The trip signal is issued after the configured operation delay unless the fault disappears before the end of the delay time.

The hysteresis, as indicated in the protection stage's characteristics data, means that the signal is regarded as a fault until the signal drops below the start setting determined by the hysteresis value.

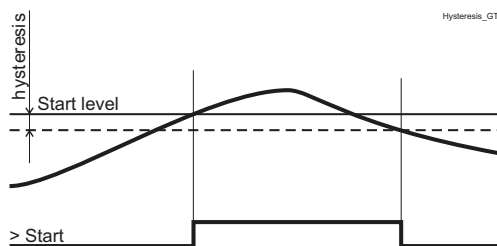

Figure 6.3: Behaviour of a greater than comparator. For example in overvoltage stages the hysteresis (dead band) acts according this figure.

### Output matrix

Using the output matrix, you can connect the internal start and trip signals to the digital outputs and indicators. For more details, see Chapter 5.4.1 Output matrix.

### Blocking

Any protection function, except arc protection, can be blocked with internal and external signals using the block matrix (Chapter 5.4.2 Blocking matrix). Internal signals are for example logic outputs and start and trip signals from other stages and external signals are for example digital and virtual inputs.

Some protection stages have also inbuilt blocking functions. For example under-frequency protection has inbuilt under-voltage blocking to avoid tripping when the voltage is off.

When a protection stage is blocked, it does not start if a fault condition is detected. If blocking is activated during the operation delay, the

delay counting is frozen until the blocking goes off or the start reason, that is the fault condition, disappears. If the stage is already tripping, the blocking has no effect.

### Dependent time operation

The operate time in the dependent time mode is dependent on the magnitude of the injected signal. The bigger the signal, the faster the stage issues a trip signal and vice versa. The tripping time calculation resets if the injected quantity drops below the start level.

### Definite time operation

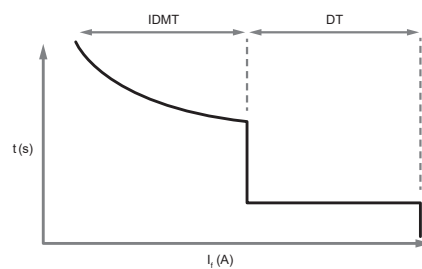

Figure 6.4: Dependent time and definite time operation curves

The operate time in the definite time mode is fixed by the operation delay setting. The timer starts when the protection stage activates and counts until the set time has elapsed. After that, the stage issues a trip command. Should the protection stage reset before the definite time operation has elapsed, then the stage resets.

### Overshoot time

Overshoot time is the time the protection relay needs to notice that a fault has been cleared during the operate time delay. This parameter is important when grading the operate time delay settings between relays.

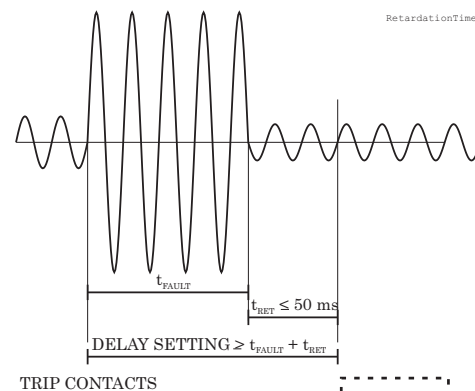

Figure 6.5: Definition for overshoot time. If the delay setting would be slightly shorter, an unselective trip might occur (the dash line pulse).

For example, when there is a big fault in an outgoing feeder, it might start both the incoming and outgoing feeder relay. However, the fault must be cleared by the outgoing feeder relay and the incoming feeder

relay must not trip. Although the operating delay setting of the incoming feeder is more than at the outgoing feeder, the incoming feeder might still trip if the operate time difference is not big enough. The difference must be more than the overshoot time of the incoming feeder relay plus the operate time of the outgoing feeder circuit breaker.

Figure 6.5 shows an overvoltage fault seen by the incoming feeder when the outgoing feeder clears the fault. If the operation delay setting would be slightly shorter or if the fault duration would be slightly longer than in the figure, an unselective trip might happen (the dashed 40 ms pulse in the figure). In Easergy P3 relays, the overshoot time is less than 50 ms.

### Reset time

Figure 6.6 shows an example of reset time, that is, release delay when the relay is clearing an overcurrent fault. When the relay's trip contacts are closed, the circuit breaker (CB) starts to open. After the CB contacts are open, the fault current still flows through an arc between the opened contacts. The current is finally cut off when the arc extinguishes at the next zero crossing of the current. This is the start moment of the reset delay. After the reset delay the trip contacts and start contact are opened unless latching is configured. The precise reset time depends on the fault size; after a big fault, the reset time is longer. The reset time also depends on the specific protection stage.

The maximum reset time for each stage is specified under the characteristics of every protection function. For most stages, it is less than 95 ms.

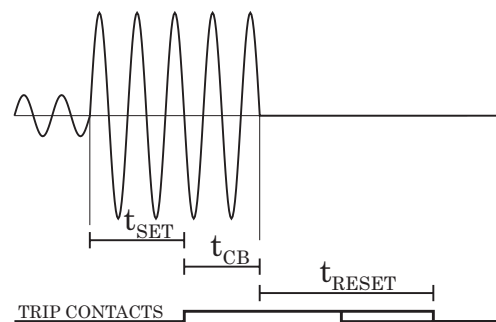

Figure 6.6: Reset time is the time it takes the trip or start relay contacts to open after the fault has been cleared.

### Hysteresis or dead band

When comparing a measured value against a start value, some amount of hysteresis is needed to avoid oscillation near equilibrium situation. With zero hysteresis, any noise in the measured signal or any noise in the measurement itself would cause unwanted oscillation between fault-on and fault-off situations.

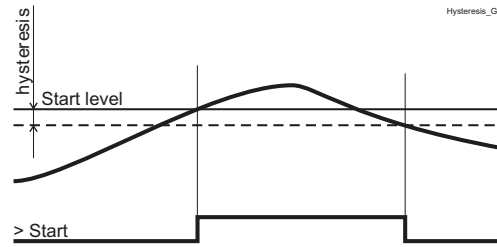

Figure 6.7: Example of behaviour of an over-protection with hysteresis

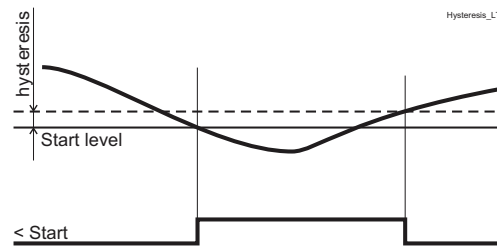

Figure 6.8: Example of behaviour of an under-protection with hysteresis

### Time grading

When a fault occurs, the protection scheme only needs to trip circuit breakers whose operation is required to isolate the fault. This selective tripping is also called discrimination or protection coordination and is typically achieved by time grading. Protection systems in successive zones are arranged to operate in times that are graded through the sequence of equipment so that upon the occurrence of a fault, although a number of protection devices respond, only those relevant to the faulty zone complete the tripping function.

The recommended discrimination time between two Easergy P3 relays in an MV network is 170–200 ms. This is based on the following facts:

- $T_c$ : circuit breaker operating time, 60 ms
- $T_m$ : upstream protection overshoot time (retardation time), 50 ms
- $\delta t$ : time delay tolerance, 25 ms
- $m$ : safety margin, 10 ms
- $\Delta t$ : discrimination time, 170–200 ms

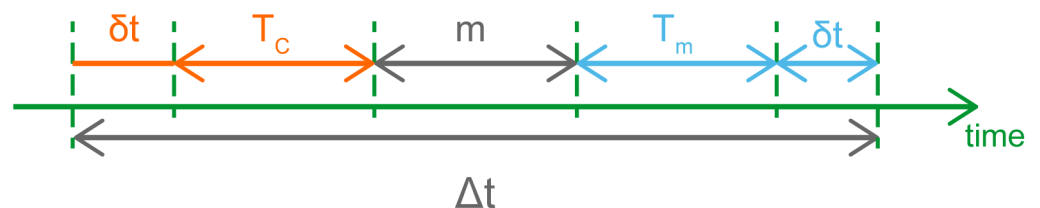

Figure 6.9: Time grading

**Recorded values of the last eight faults**

There is detailed information available on the last eight faults for each protection stage. The recorded values are specific for the protection stages and can contain information like time stamp, fault value, elapsed delay, fault current, fault voltage, phase angle and setting group.

**NOTE:** The recorded values are lost if the relay power is switched off.



## 6.3 Dependent operate time

The dependent operate time - that is, the inverse definite minimum time (IDMT) type of operation - is available for several protection functions. The common principle, formulae and graphic representations of the available dependent delay types are described in this chapter.

Dependent delay means that the operate time depends on the measured real time process values during a fault. For example, with an overcurrent stage using dependent delay, a bigger a fault current gives faster operation. The alternative to dependent delay is definite delay. With definite delay, a preset time is used and the operate time does not depend on the size of a fault.

### Stage-specific dependent delay

Some protection functions have their own specific type of dependent delay. Details of these dedicated dependent delays are described with the appropriate protection function.

### Operation modes

There are three operation modes to use the dependent time characteristics:

- **Standard delays**  
Using standard delay characteristics by selecting a curve family (IEC, IEEE, IEEE2, RI) and a delay type (Normal inverse, Very inverse etc). See Chapter 6.3.1 Standard dependent delays using IEC, IEEE, IEEE2 and RI curves.
- **Standard delay formulae with free parameters**  
selecting a curve family (IEC, IEEE, IEEE2) and defining one's own parameters for the selected delay formula. This mode is activated by setting delay type to 'Parameters', and then editing the delay function parameters A – E. See Chapter 6.3.2 Free parameterization using IEC, IEEE and IEEE2 curves.
- **Fully programmable dependent delay characteristics**  
Building the characteristics by setting 16 [current, time] points. The relay interpolates the values between given points with second degree polynomials. This mode is activated by the setting curve family to 'PrgN'. There is a maximum of three different programmable curves available at the same time. Each programmed curve can be used by any number of protection stages. See Chapter 6.3.3 Programmable dependent time curves.

### Dependent time limitation

The maximum dependent time is limited to 600 seconds.

### Local panel graph

The relay shows a graph of the currently used dependent delay on the local panel display. The up and down keys can be used for zooming. Also the delays at  $20 \times I_{SET}$ ,  $4 \times I_{SET}$  and  $2 \times I_{SET}$  are shown.

### Dependent time setting error signal

If there are any errors in the dependent delay configuration, the appropriate protection stage uses the definite time delay.

There is a signal 'Setting Error' available in the output matrix that indicates different situations:

1. Settings are currently changed with Easergy Pro or local panel.
2. There is temporarily an illegal combination of curve points. For example, if previous setting was IEC/NI and then curve family is changed to IEEE, this causes a setting error because there is no NI type available for IEEE curves. After changing valid delay type for IEEE mode (for example MI), the 'Setting Error' signal releases.
3. There are errors in formula parameters A – E, and the relay is not able to build the delay curve.
4. There are errors in the programmable curve configuration, and the relay is not able to interpolate values between the given points.

### Limitations

The maximum measured secondary phase current is  $50 \times I_N$  and the maximum directly measured earth fault current is  $10 \times I_{0N}$  for earth fault overcurrent input. The full scope of dependent delay curves goes up to 20 times the setting. At a high setting, the maximum measurement capability limits the scope of dependent curves according to Table 6.1.

**Table 6.1: Maximum measured secondary currents and settings for phase and earth fault overcurrent inputs**

Current input	Maximum measured secondary current	Maximum secondary scaled setting enabling dependent delay times up to full 20x setting
$I_{L1}$ , $I_{L2}$ , $I_{L3}$ and $I_{0Calc}$	250 A	12.5 A
$I_{01} = 5 \text{ A}$	50 A	2.5 A
$I_{01} = 1 \text{ A}$	10 A	0.5 A
$I_{01} = 0.2 \text{ A}$	2 A	0.1 A

### 1. Example of limitation

$$CT = 750 / 5$$

$CT_0 = 100 / 1$  (cable CT is used for earth fault overcurrent)

The  $CT_0$  is connected to a 1 A terminals of input  $I_{01}$ .

For overcurrent stage  $I>$ , Table 6.1 gives 12.5 A. Thus, the maximum setting for the  $I>$  stage giving full dependent delay range is  $12.5 \text{ A} / 5 \text{ A} = 2.5 \times I_N = 1875 \text{ A}_{\text{Primary}}$ .

For earth fault stage  $I_0>$ , Table 6.1 gives 0.5 A. Thus, the maximum setting for the  $I_0>$  stage giving full dependent delay range is  $0.5 \text{ A} / 1 \text{ A} = 0.5 \times I_{0N} = 50 \text{ A}_{\text{Primary}}$ .

### 2. Example of limitation

$$CT = 750 / 5$$

Application mode is Motor

Rated current of the motor = 600 A

$I_{0\text{Calc}} (= I_{L1} + I_{L2} + I_{L3})$  is used for earth fault overcurrent

At secondary level, the rated motor current is  $600 / 750 \times 5 = 4 \text{ A}$

For overcurrent stage  $I>$ , Table 6.1 gives 12.5 A. Thus, the maximum setting giving full dependent delay range is  $12.5 \text{ A} / 4 \text{ A} = 3.13 \times I_{\text{MOT}} = 1875 \text{ A}_{\text{Primary}}$ .

For earth fault stage  $I_0>$ , Table 6.1 gives 12.5 A. Thus, the maximum setting for the  $I_0>$  stage giving full dependent delay range is  $12.5 \text{ A} / 5 \text{ A} = 2.5 \times I_{0N} = 1875 \text{ A}_{\text{Primary}}$ .

## 6.3.1

### Standard dependent delays using IEC, IEEE, IEEE2 and RI curves

The available standard dependent delays are divided in four categories called dependent curve families: IEC, IEEE, IEEE2 and RI. Each category contains a set of different delay types according to Table 6.2.

#### Dependent time setting error signal

The dependent time setting error signal activates if the delay category is changed and the old delay type does not exist in the new category. See Chapter 6.3 Dependent operate time for more details.

#### Limitations

The minimum definite time delay starts when the measured value is twenty times the setting, at the latest. However, there are limitations at high setting values due to the measurement range. See Chapter 6.3 Dependent operate time for more details.

**Table 6.2: Available standard delay families and the available delay types within each family.**

Delay type		Curve family				
		DT	IEC	IEEE	IEEE2	RI
<b>DT</b>	Definite time	X				
<b>NI</b>	Normal inverse		X		X	
<b>VI</b>	Very inverse		X	X	X	
<b>EI</b>	Extremely inverse		X	X	X	
<b>LTI</b>	Long time inverse		X	X		
<b>LTEI</b>	Long time extremely inverse			X		
<b>LTVI</b>	Long time very inverse			X		
<b>MI</b>	Moderately inverse			X	X	
<b>STI</b>	Short time inverse			X		
<b>STEI</b>	Short time extremely inverse			X		
<b>RI</b>	Old ASEA type					X
<b>RXIDG</b>	Old ASEA type					X

### IEC dependent operate time

The operate time depends on the measured value and other parameters according to Equation 6.1. Actually this equation can only be used to draw graphs or when the measured value  $I$  is constant during the fault. A modified version is implemented in the relay for real time usage.

Equation 6.1:

$$t = \frac{k A}{\left(\frac{I}{I_{START}}\right)^B} - 1$$

$t$  = Operation delay in seconds  
 $k$  = User's multiplier Inv. time coefficient  $k$   
 $I$  = Measured value  
 $I_{START}$  = Start setting  
 $A, B$  = Constants parameters according Table 6.3.

There are three different dependent delay types according to IEC 60255-3, Normal inverse (NI), Extremely inverse (EI), Very inverse (VI) and a VI extension. In addition, there is a de facto standard Long time inverse (LTI).

**Table 6.3: Constants for IEC dependent delay equation**

Delay type		Parameter	
		A	B
NI	Normal inverse	0.14	0.02
EI	Extremely inverse	80	2
VI	Very inverse	13.5	1
LTI	Long time inverse	120	1

**Example of the delay type "Normal inverse (NI)":**

$k = 0.50$

$I = 4 \text{ pu (constant current)}$

$I_{PICKUP} = 2 \text{ pu}$

$A = 0.14$

$B = 0.02$

$$t = \frac{0.50 \cdot 0.14}{\left(\frac{4}{2}\right)^{0.02} - 1} = 5.0$$

The operate time in this example is five seconds. The same result can be read from Figure 6.10.

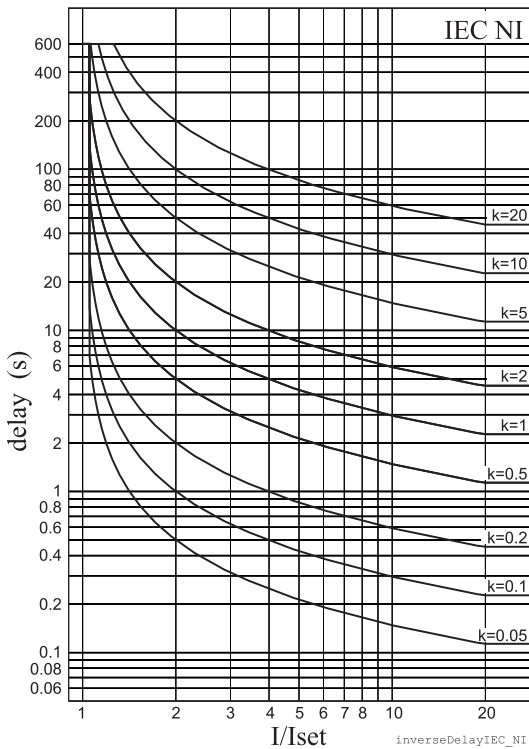

Figure 6.10: IEC normal inverse delay

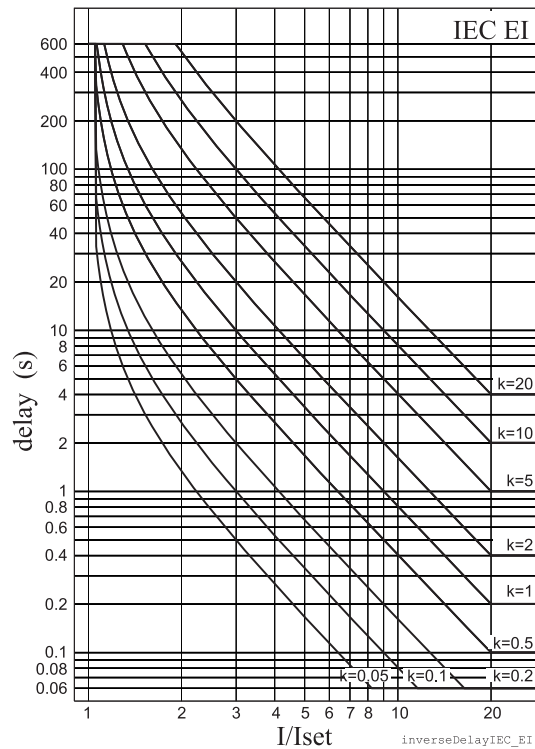

Figure 6.11: IEC extremely inverse delay

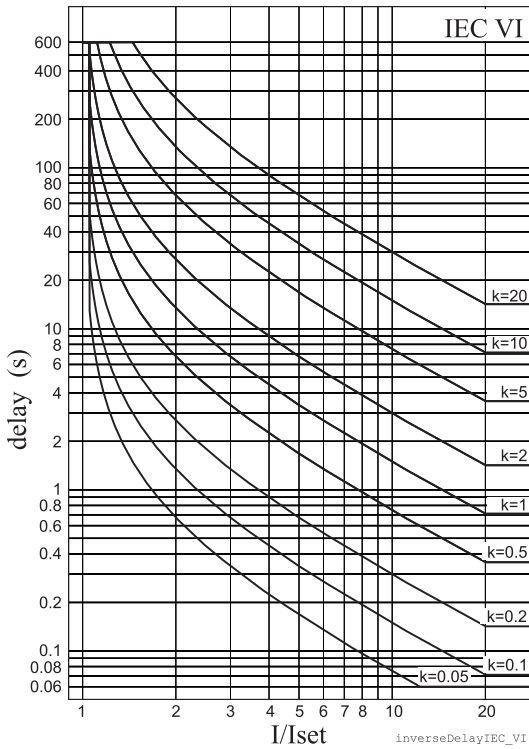

Figure 6.12: IEC very inverse delay

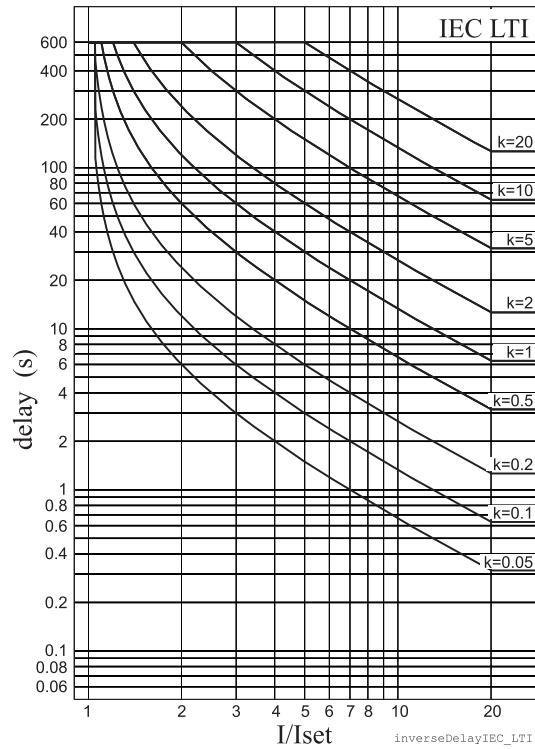

Figure 6.13: IEC long time inverse delay

**IEEE/ANSI dependent operate time**

There are three different delay types according to IEEE Std C37.112-1996 (MI, VI, EI) and many de facto versions according to Table 6.4. The IEEE standard defines dependent delay for both trip and release operations. However, in the Easergy P3 relay only the trip time is dependent according to the standard but the reset time is constant.

The operate delay depends on the measured value and other parameters according to Equation 6.2. Actually, this equation can only be used to draw graphs or when the measured value I is constant during the fault. A modified version is implemented in the relay for real-time usage.

Equation 6.2:

$$t = k \left[ \frac{A}{\left( \frac{I}{I_{START}} \right)^C - 1} + B \right]$$

t = Operation delay in seconds

k = User's multiplier

I = Measured value

I<sub>START</sub> = Start setting

A,B,C = Constant parameter according to Table 6.4.

**Table 6.4: Constants for IEEE/ANSI inverse delay equation**

Delay type		Parameter		
		A	B	C
LTI	Long time inverse	0.086	0.185	0.02
LTVI	Long time very inverse	28.55	0.712	2
LTEI	Long time extremely inverse	64.07	0.250	2
MI	Moderately inverse	0.0515	0.1140	0.02
VI	Very inverse	19.61	0.491	2
EI	Extremely inverse	28.2	0.1217	2
STI	Short time inverse	0.16758	0.11858	0.02
STEI	Short time extremely inverse	1.281	0.005	2

**Example of the delay type "Moderately inverse (MI)":**

$$k = 0.50$$

$$I = 4 \text{ pu}$$

$$I_{\text{PICKUP}} = 2 \text{ pu}$$

$$A = 0.0515$$

$$B = 0.114$$

$$C = 0.02$$

$$t = 0.50 \cdot \left[ \frac{0.0515}{\left(\frac{4}{2}\right)^{0.02} - 1} + 0.1140 \right] = 1.9$$

The operate time in this example is 1.9 seconds. The same result can be read from Figure 6.17.

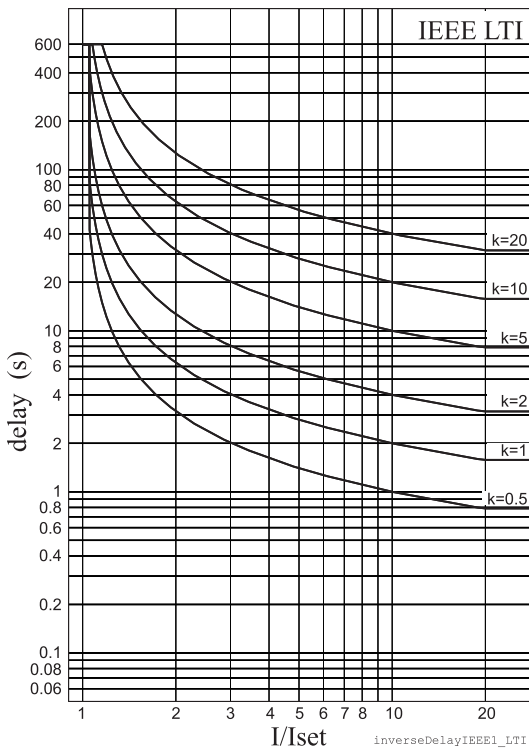

Figure 6.14: ANSI/IEEE long time inverse delay

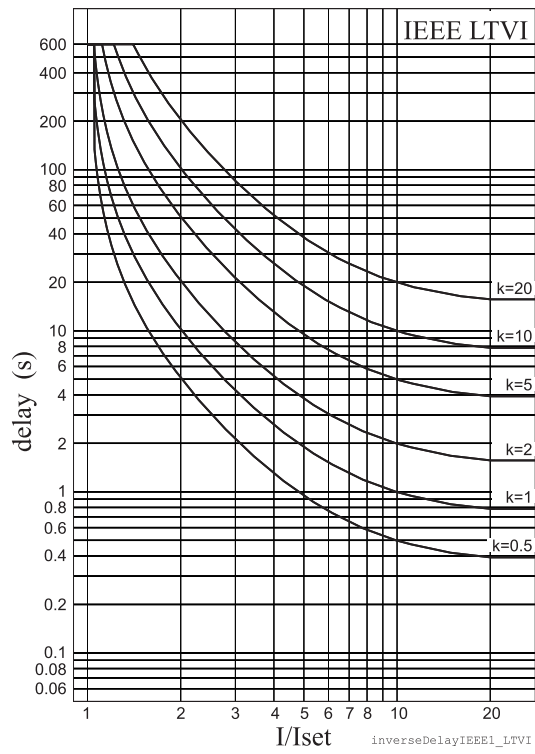

Figure 6.15: ANSI/IEEE long time very inverse delay

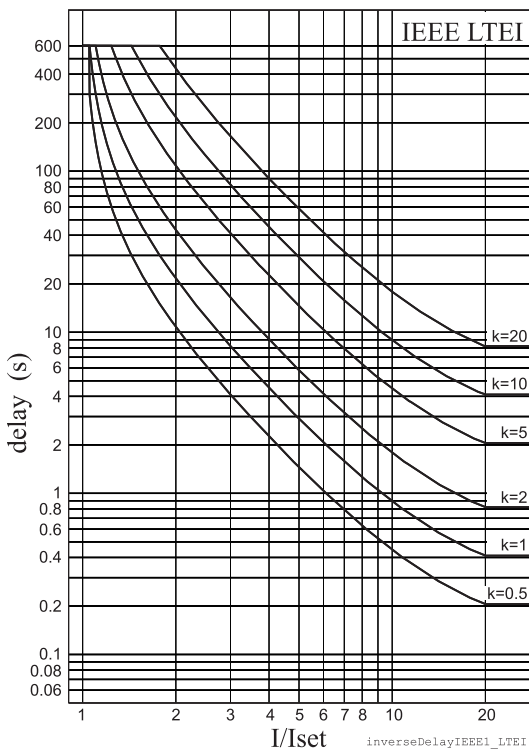

Figure 6.16: ANSI/IEEE long time extremely inverse delay

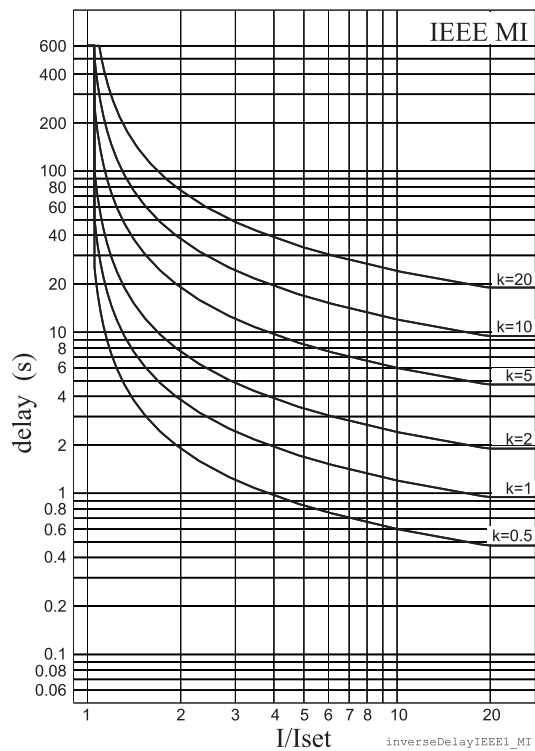

Figure 6.17: ANSI/IEEE moderately inverse delay



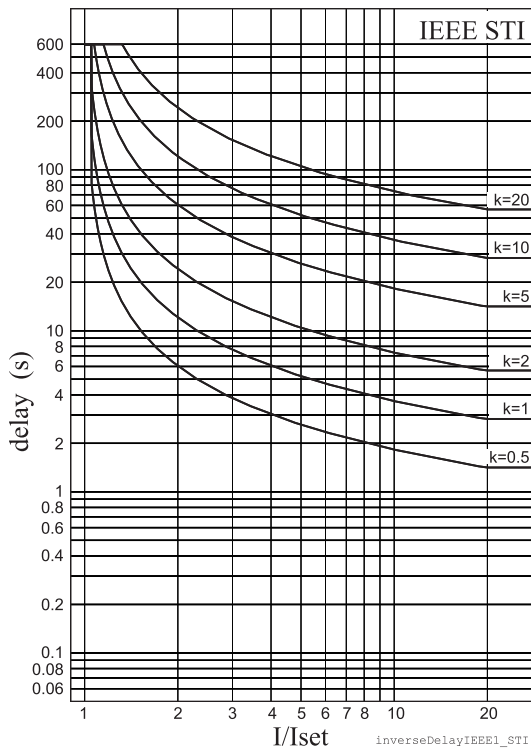

Figure 6.18: ANSI/IEEE short time inverse delay

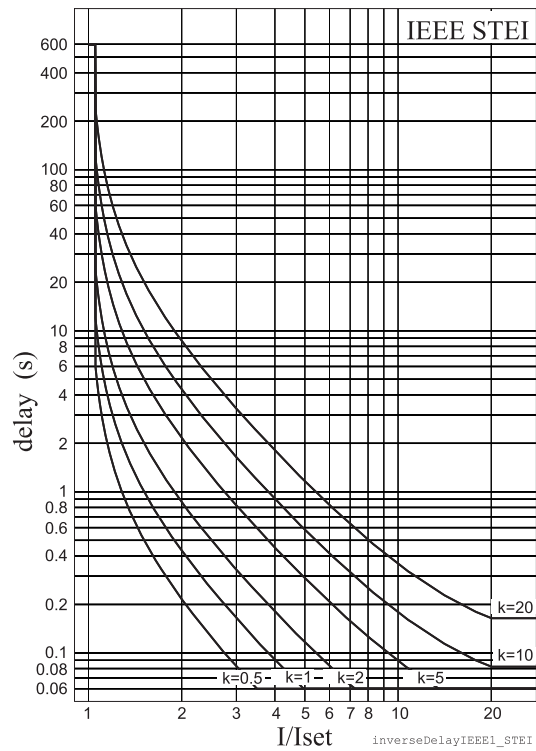

Figure 6.19: ANSI/IEEE short time extremely inverse delay

### IEEE2 dependent operate time

Before the year 1996 and ANSI standard C37.112 microprocessor relays were using equations approximating the behaviour of various induction disc type relays. A quite popular approximation is Equation 6.3 which in Easergy P3 relays is called IEEE2. Another name could be IAC because the old General Electric IAC relays have been modeled using the same equation.

There are four different delay types according to Table 6.5. The old electromechanical induction disc relays have dependent delay for both trip and release operations. However, in Easergy P3 relays, only the trip time is dependent and the reset time is constant.

The operate delay depends on the measured value and other parameters according to Equation 6.3. Actually, this equation can only be used to draw graphs or when the measured value  $I$  is constant during the fault. A modified version is implemented in the relay for real-time usage.

Equation 6.3:

$$t = k \left[ A + \frac{B}{\left( \frac{I}{I_{START}} - C \right)} + \frac{D}{\left( \frac{I}{I_{START}} - C \right)^2} + \frac{E}{\left( \frac{I}{I_{START}} - C \right)^3} \right]$$

t = Operation delay in seconds

k = User's multiplier

I = Measured value

I<sub>START</sub> = User's start setting

A, B, C, D = Constant parameter according Table 6.5.

**Table 6.5: Constants for IEEE2 inverse delay equation**

Delay type		Parameter				
		A	B	C	D	E
MI	Moderately inverse	0.1735	0.6791	0.8	-0.08	0.1271
NI	Normally inverse	0.0274	2.2614	0.3	-0.1899	9.1272
VI	Very inverse	0.0615	0.7989	0.34	-0.284	4.0505
EI	Extremely inverse	0.0399	0.2294	0.5	3.0094	0.7222

**Example of the delay type "Moderately inverse (MI)":**

k = 0.50

I = 4 pu

I<sub>START</sub> = 2 pu

A = 0.1735

B = 0.6791

C = 0.8

D = -0.08

E = 0.127

$$t = 0.5 \cdot \left[ 0.1735 + \frac{0.6791}{\left( \frac{4}{2} - 0.8 \right)} + \frac{-0.08}{\left( \frac{4}{2} - 0.8 \right)^2} + \frac{0.127}{\left( \frac{4}{2} - 0.8 \right)^3} \right] = 0.38$$

The operate time in this example is 0.38 seconds. The same result can be read from Figure 6.20.

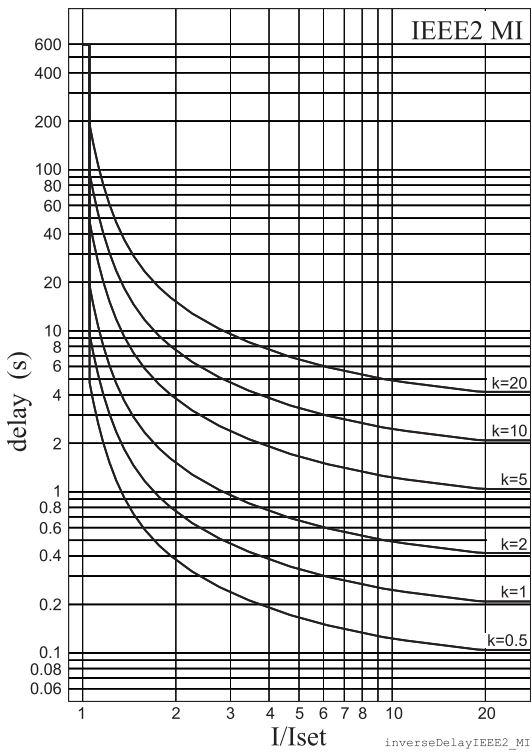

Figure 6.20: IEEE2 moderately inverse delay

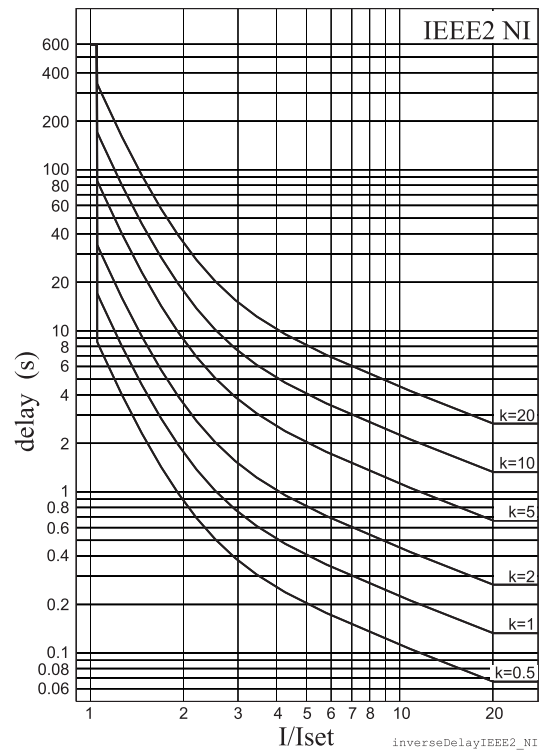

Figure 6.21: IEEE2 normal inverse delay

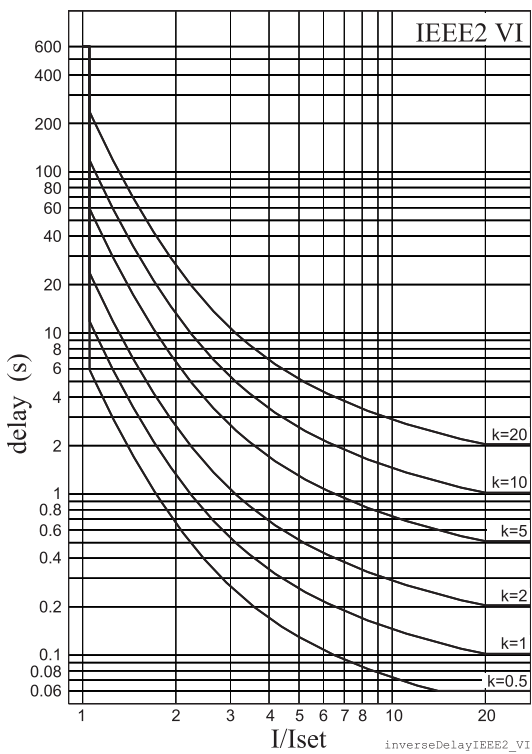

Figure 6.22: IEEE2 very inverse delay

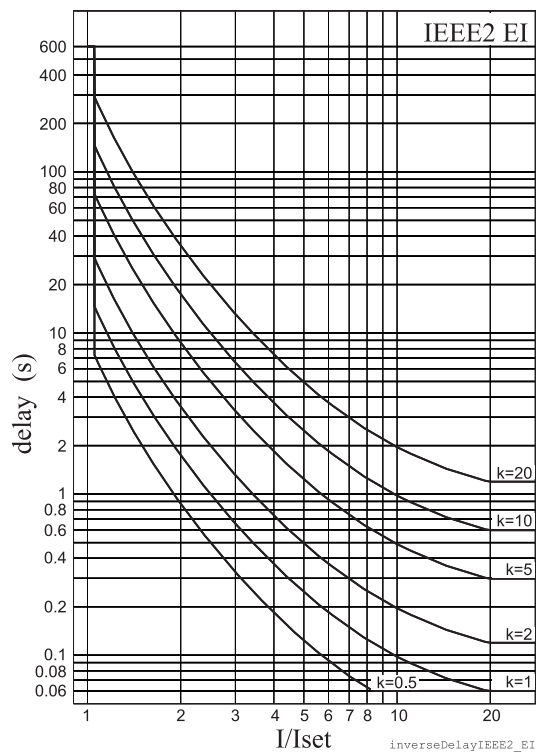

Figure 6.23: IEEE2 extremely inverse delay

### RI and RXIDG type dependent operate time

These two dependent delay types have their origin in old ASEA (nowadays ABB) earth fault relays.

The operate delay of types RI and RXIDG depends on the measured value and other parameters according to Equation 6.4 and Equation 6.5. Actually, these equations can only be used to draw graphs or when the measured value  $I$  is constant during the fault. Modified versions are implemented in the relay for real-time usage.

Equation 6.4: RI

$$t_{RI} = \frac{k}{0.339 - \frac{0.236}{\left(\frac{I}{I_{START}}\right)}}$$

Equation 6.5: RXIDG

$$t_{RXIDG} = 5.8 - 1.35 \ln \frac{I}{k I_{START}}$$

$t$  = Operate delay in seconds

$k$  = User's multiplier

$I$  = Measured value

$I_{START}$  = Start setting

#### Example of the delay type RI

$k = 0.50$

$I = 4 \text{ pu}$

$I_{START} = 2 \text{ pu}$

$$t_{RI} = \frac{0.5}{0.339 - \frac{0.236}{\left(\frac{4}{2}\right)}} = 2.3$$

The operate time in this example is 2.3 seconds. The same result can be read from Figure 6.24.

#### Example of the delay type RXIDG

$k = 0.50$

$I = 4 \text{ pu}$

$I_{START} = 2 \text{ pu}$

$$t_{RXIDG} = 5.8 - 1.35 \ln \frac{4}{0.5 \cdot 2} = 3.9$$

The operate time in this example is 3.9 seconds. The same result can be read from Figure 6.25.

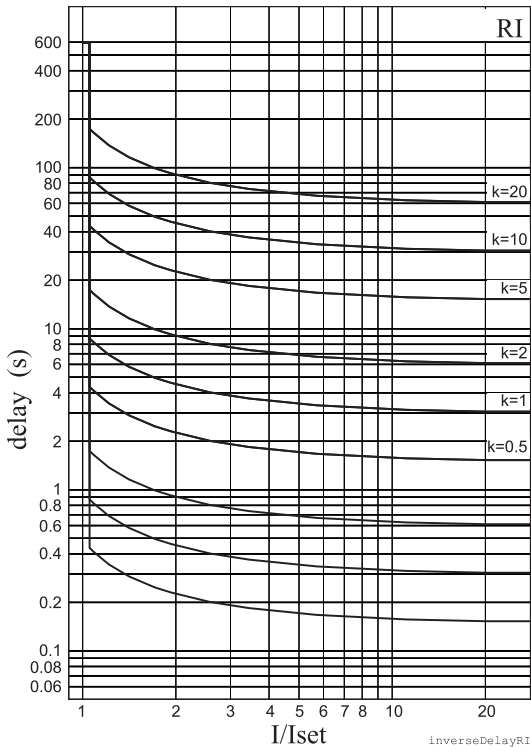

Figure 6.24: RI dependent delay

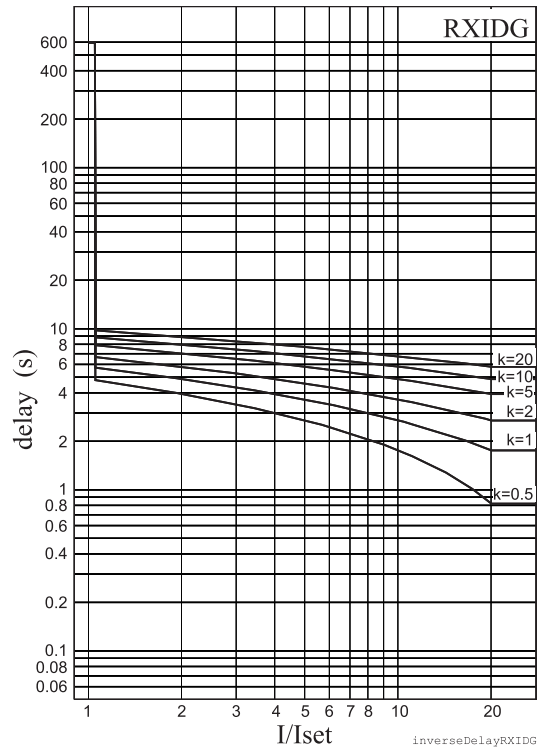

Figure 6.25: RXIDG dependent delay

## 6.3.2 Free parameterization using IEC, IEEE and IEEE2 curves

This mode is activated by the setting delay type to 'Parameters', and then editing the delay function constants, that is, the parameters A – E. The idea is to use the standard equations with one's own constants instead of the standardized constants as in the previous chapter.

### Example of the GE-IAC51 delay type:

$$k = 0.50$$

$$I = 4 \text{ pu}$$

$$I_{\text{START}} = 2 \text{ pu}$$

$$A = 0.2078$$

$$B = 0.8630$$

$$C = 0.8000$$

$$D = -0.4180$$

$$E = 0.1947$$

$$t = 0.5 \cdot \left[ 0.2078 + \frac{0.8630}{\left(\frac{4}{2} - 0.8\right)} + \frac{-0.4180}{\left(\frac{4}{2} - 0.8\right)^2} + \frac{0.1947}{\left(\frac{4}{2} - 0.8\right)^3} \right] = 0.37$$

The operate time in this example is 0.37 seconds.

The resulting time/current characteristic of this example matches quite well the characteristic of the old electromechanical IAC51 induction disc relay.

### Dependent time setting error signal

The dependent time setting error signal activates if interpolation with the given parameters is not possible. See Chapter 6.3 Dependent operate time for more details.

### Limitations

The minimum definite time delay starts at the latest when the measured value is twenty times the setting. However, there are limitations at high setting values due to the measurement range. See Chapter 6.3 Dependent operate time for more details.

### 6.3.3 Programmable dependent time curves

Programming dependent time curves requires Easergy Pro setting tool and rebooting the unit.

The [current, time] curve points are programmed using Easergy Pro PC program. There are some rules for defining the curve points:

- the configuration must begin from the topmost line
- the line order must be as follows: the smallest current (longest operate time) on the top and the largest current (shortest operate time) on the bottom
- all unused lines (on the bottom) should be filled with [1.00 0.00s]

Here is an example configuration of curve points:

Point	Current I/I <sub>START</sub>	Operate delay
1	1.00	10.00 s
2	2.00	6.50 s
3	5.00	4.00 s
4	10.00	3.00 s
5	20.00	2.00 s
6	40.00	1.00 s
7	1.00	0.00 s
8	1.00	0.00 s
9	1.00	0.00 s
10	1.00	0.00 s
11	1.00	0.00 s
12	1.00	0.00 s
13	1.00	0.00 s
14	1.00	0.00 s
15	1.00	0.00 s
16	1.00	0.00 s

#### Dependent time setting error signal

The dependent time setting error signal activates if interpolation with the given points fails. See Chapter 6.3 Dependent operate time for more details.

#### Limitations

The minimum definite time delay starts at the latest when the measured value is twenty times the setting. However, there are limitations at high setting values due to the measurement range. See Chapter 6.3 Dependent operate time for more details.

## 6.4 Synchrocheck (ANSI 25)

### Description

The relay includes a synchrocheck function that checks the synchronism before giving or enabling the circuit breaker close command. The function monitors the voltage amplitude, frequency and phase angle difference between two voltages. Since there are two stages available, it is possible to monitor three voltages. The voltages can be busbar and line or busbar and busbar (bus coupler).

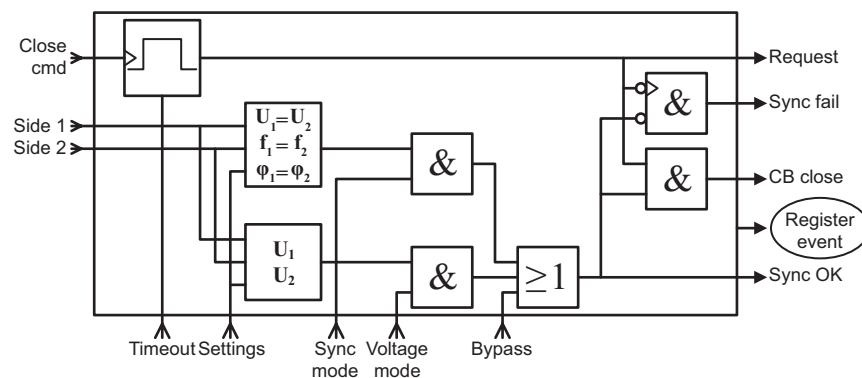

Figure 6.26: Synchrocheck function

The synchrocheck stage includes two separate synchronism criteria that can be used separately or combined:

- voltage only
- voltage, frequency, and phase

The voltage check simply compares voltage conditions of the supervised objects. The supervised object is considered dead (not energized) when the measured voltage is below the  $U_{dead}$  setting limit. Similarly, the supervised object is considered live (energized) when the measured voltage is above the  $U_{live}$  setting limit. Based on the measured voltage conditions and the selected voltage check criteria, synchronism is declared.

When the network sections to be connected are part of the same network, the frequency and phase are the same. Therefore, the voltage check criteria is safe to use without frequency and phase check.

The frequency and phase check compares the voltages, frequency and phase of the supervised objects. Synchronism is declared if the voltages are above the  $U_{live}$  limit and all three difference criteria are within the given limits. This synchronism check is dynamic by nature, and the object close command is given at a certain moment of time, depending on the selected mode of operation.

When two networks are running at slightly different frequencies, there is also a phase difference between these two networks. Because of the different frequency, the phase angle tends to rotate. The time for one cycle depends on the frequency difference. The stress for



electrical components is lowest when two networks are connected at zero phase difference.

In the “Sync” mode, the circuit breaker closing is aimed at the moment of zero phase difference. Therefore, the close command is advanced by the time defined by the CB close time setting. In the “Async” mode, the circuit breaker closing is aimed at the moment when the synchronism conditions are met, that is, when the phase difference is within the given phase difference limit.

When two network sections to be connected are from different sources or generators, the voltage criteria alone is not safe, so also frequency and phase check must be used.

When two networks with different frequencies are to be connected, the request timeout setting must be long enough to allow the synchronism criteria to be met. For example, if the frequency difference is 0.1 Hz, the synchronism criteria is met only once in ten seconds.

The synchrocheck stage starts from an object close command that generates a request to close the selected circuit breaker when the synchronism conditions are met. The synchrocheck stage provides a "request" signal that is active from the stage start until the synchronism conditions are met or the request timeout has elapsed. When the synchronism conditions are not met within the request timeout, a “fail” pulse is generated. The fail pulse has a fixed length of 200 ms. When the synchronism conditions are met in a timely manner, the object close command is initiated for the selected object. This signal is purely internal and not available outside the synchrocheck stage. When the synchronism conditions are met, the “OK” signal is always active. The activation of the bypass input bypasses the synchronism check and declares synchronism at all times.

The request, OK, and fail signals are available in the output matrix. The synchronized circuit breaker close execution order is shown in Figure 6.27.

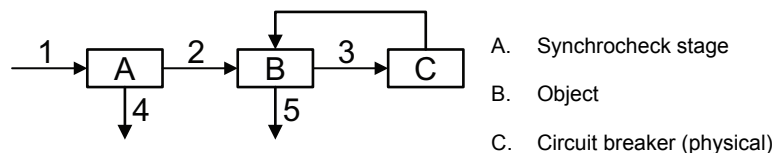

1. Object close command from mimic, digital inputs or communication protocol
2. Synchronism declared
3. Circuit breaker close command
4. Sync fail signal if request timeout elapsed before synchronism conditions met
5. Object fail signal if CB failed to operate

Figure 6.27: Synchrocheck execution order

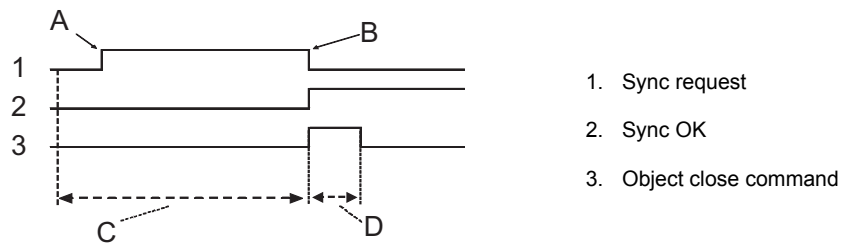

- A. The object close command given (minic or bus) actually only makes a sync request.
- B. The sync request ends when the synchronism conditions are met and CB command is given or if the request timeout elapsed.
- C. If the request timeout elapsed before synchronism conditions are met, sync fail pulse is generated.
- D. Normal object close operation

Figure 6.28: Synchrocheck function principle

The synchrocheck function is available when one of the following analog measurement modules and a suitable measuring mode are in use:

Voltage measuring mode	Number of synchrocheck stages
3LN+LLy	1
3LN+LNy	1
2LL+U <sub>0</sub> +LLy	1
2LL+U <sub>0</sub> +LNy	1
LL+U <sub>0</sub> +LLy+LLz	2
LN+U <sub>0</sub> +LNy+LNz	2

### Connections for synchrocheck

The voltage used for synchrochecking is always line-to-line voltage U<sub>12</sub> even when U<sub>L1</sub> is measured. The synchrocheck stage 1 always compares U<sub>12</sub> with U<sub>12y</sub>. The compared voltages for the stage 2 can be selected (U<sub>12</sub> / U<sub>12y</sub>, U<sub>12</sub> / U<sub>12z</sub>, U<sub>12y</sub> / U<sub>12z</sub>). See Chapter 10.6 Voltage measurement modes.

**NOTE:** To perform its operation, the synchrocheck stage 2 converts the voltages LN<sub>y</sub> and LN<sub>z</sub> to line-to-line voltage U<sub>12</sub>. As such, the measured voltage for LN<sub>y</sub> and LN<sub>z</sub> must be U<sub>1-N</sub>.

**NOTE:** The wiring of the secondary circuits of voltage transformers to the relay terminal depends on the selected voltage measuring mode.

See the synchrocheck stage's connection diagrams in Chapter 10.6 Voltage measurement modes.

## Characteristics

**Table 6.6: Synchrocheck function  $\Delta f$ ,  $\Delta U$ ,  $\Delta\phi$  (25)**

Input signal	$U_{L1} - U_{L4}$
Synchrocheck mode ( $S_{MODE}$ )	Off; Async; Sync *
Voltage check mode ( $U_{MODE}$ )	DD; DL; LD; DD/DL; DD/LD; DL/LD; DD/DL/LD **
CB closing time	0.04 – 0.6 s
$U_{DEAD}$ limit setting	10 – 120 % $U_N$
$U_{LIVE}$ limit setting	10 – 120 % $U_N$
Frequency difference	0.01 – 1.00 Hz
Voltage difference	1 – 60 % $U_N$
Phase angle difference	2° – 90°
Request timeout	0.1 – 600.0 s
Stage operation range	46.0 – 64.0 Hz
Reset ratio (U)	<0.97
Inaccuracy: - voltage - frequency - phase angle - operate time	$\pm 3$ % $U_N$ $\pm 20$ mHz $\pm 2^\circ$ (when $\Delta f < 0.2$ Hz, else $\pm 5^\circ$ ) $\pm 1\%$ or $\pm 30$ ms

\*)

- Off – Frequency and phase criteria not in use
- Async –  $d_F$ ,  $d_U$  and  $d$  angle criteria are used. Circuit breaker close is aimed at the moment when the phase angle is within phase angle difference limit. Slip frequency  $d_F$  determines how much the close command needs to be advanced to make the actual connection at the moment when the phase angle is within the phase angle limit.
- Sync mode –  $d_F$ ,  $d_U$  and  $d$  angle criteria are used. Circuit breaker close is aimed at the moment when the phase angle becomes zero. Slip frequency  $d_F$  determines how much the close command needs to be advanced to make the actual connection at zero phase angle.

\*\*)

- The first letter refers to the reference voltage and the second letter to the comparison voltage.
- D means that the side must be “dead” when closing (dead = The voltage is below the dead voltage limit setting).
- L means that the side must be “live” when closing (live = The voltage is higher than the live voltage limit setting).
- Example: DL mode for stage 1: The U12 side must be “dead” and the U12y side must be “live”.

---

## 6.5 Undervoltage (ANSI 27)

### Description

Undervoltage protection is used to detect voltage dips or sense abnormally low voltages to trip or trig load shedding or load transfer. The function measures the three line-to-line voltages, and whenever the smallest of them drops below the start setting of a particular stage, this stage starts and a start signal is issued. If the fault situation remains on longer than the operate time delay setting, a trip signal is issued.

### Blocking during voltage transformer fuse failure

As all the protection stages, the undervoltage function can be blocked with any internal or external signal using the block matrix. For example if the secondary voltage of one of the measuring transformers disappears because of a fuse failure (See the voltage transformer supervision function in Chapter 7.8 Voltage transformer supervision (ANSI 60FL)). The blocking signal can also be a signal from the custom logic (see Chapter 5.7 Logic functions).

### Low-voltage self blocking

The stages can be blocked with a separate low-limit setting. With this setting, the particular stage is blocked when the biggest of the three line-to-line voltages drops below the given limit. The idea is to avoid unwanted tripping when the voltage is switched off. If the operate time is less than 0.08 s, the blocking level setting should not be less than 15 % for the blocking action to be fast enough. The self blocking can be disabled by setting the low-voltage block limit equal to zero.

Figure 6.29 shows an example of low voltage self blocking.

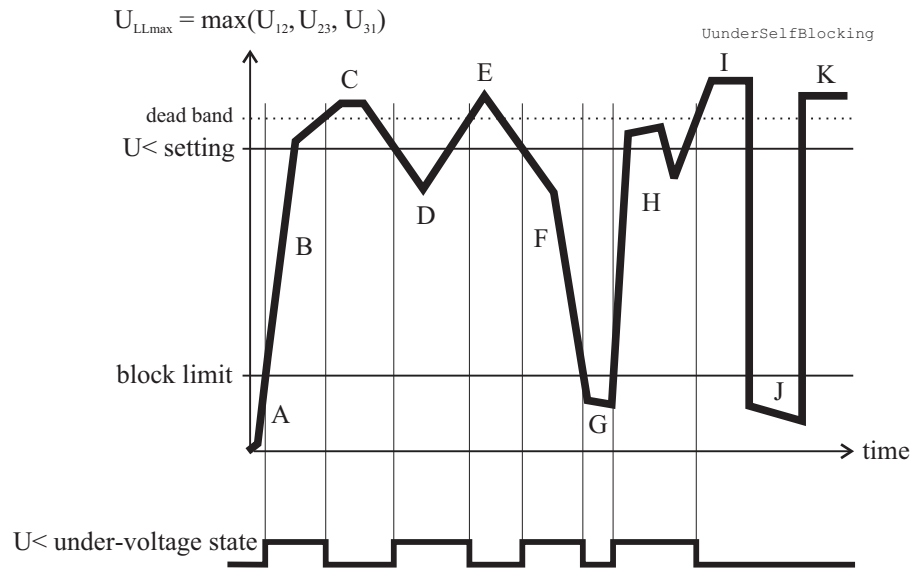

Figure 6.29: Under voltage state and block limit

- |  |   |
|--|---|
| <p>A The maximum of the three line-to-line voltages <math>U_{LLmax}</math> is below the block limit. This is not regarded as an under-voltage situation.</p> | <p>F This is an undervoltage situation.</p>   |
| <p>B The voltage <math>U_{LLmin}</math> is above the block limit but below the start level. This is an under-voltage situation.</p>                          | <p>G The voltage <math>U_{LLmin}</math> is under block limit and this is not regarded as an undervoltage situation.</p> |
| <p>C The voltage is OK because it is above the start limit.</p>  | <p>H This is an undervoltage situation.</p>   |
| <p>D This is an undervoltage situation.</p>  | <p>I Voltage is OK.</p>   |
| <p>E Voltage is OK.</p>  | <p>J Same as G</p>  |
|  | <p>K Voltage is OK.</p>   |

### Three independent stages

There are three separately adjustable stages:  $U<$ ,  $U<<$  and  $U<<<$ . All these stages can be configured for the definite time (DT) operation characteristic.

### Setting groups

There are four setting groups available for all stages.

## Characteristics

**Table 6.7: Undervoltage  $U<$  (27)**

Input signal	$U_{L1} - U_{L3}$
Start value	20 – 120 % $U_N$ (step 1%)
Definite time characteristic: - Operate time	0.08** – 300.00 s (step 0.02)
Hysteresis (reset ratio)	1.001 – 1.200 (0.1 – 20.0 %, step 0.1 %)
Self-blocking value of the undervoltage	0 – 80 % $U_N$
Start time	Typically 60 ms
Release delay	0.06 – 300.00 s (step 0.02 s)
Reset time	<95 ms
Overshoot time	< 50 ms
Reset ratio (Block limit)	0.5 V or 1.03 (3 %)
Reset ratio	1.03 (depends on the hysteresis setting)
Inaccuracy: - Starting - Blocking - Operate time	$\pm 3\%$ of the set value $\pm 3\%$ of set value or $\pm 0.5$ V $\pm 1\%$ or $\pm 30$ ms

**Table 6.8: Undervoltage  $U<<$  (27)**

Input signal	$U_{L1} - U_{L3}$
Start value	20 – 120 % $U_N$ (step 1%)
Definite time characteristic: - Operate time	0.06** – 300.00 s (step 0.02)
Hysteresis (reset ratio)	1.001 – 1.200 (0.1 – 20.0 %, step 0.1 %)
Self-blocking value of the undervoltage	0 – 80 % $U_N$
Start time	Typically 60 ms
Reset time	<95 ms
Overshoot time	< 50 ms
Reset ratio (Block limit)	0.5 V or 1.03 (3 %)
Reset ratio	1.03 (depends on the hysteresis setting)
Inaccuracy: - Starting - Blocking - Operate time	$\pm 3\%$ of the set value $\pm 3\%$ of set value or $\pm 0.5$ V $\pm 1\%$ or $\pm 30$ ms

**Table 6.9: Undervoltage  $U_{<<<}$  (27)**

Input signal	$U_{L1} - U_{L3}$
Start value	20 – 120 % $U_N$ (step 1%)
Definite time characteristic: - Operate time	0.04** – 300.00 s (step 0.01)
Hysteresis (reset ratio)	1.001 – 1.200 (0.1 – 20.0 %, step 0.1 %)
Self-blocking value of the undervoltage	0 - 80 % $U_N$
Start time	Typically 30 ms
Reset time	<95 ms
Overshoot time	< 50 ms
Reset ratio (Block limit)	0.5 V or 1.03 (3 %)
Reset ratio	1.03 (depends on the hysteresis setting)
Inaccuracy: - Starting - Blocking - Operate time	$\pm 3\%$ of the set value $\pm 3\%$ of set value or $\pm 0.5$ V $\pm 1\%$ or $\pm 25$ ms

\*\*\*) This is the instantaneous time i.e. the minimum total operational time including the fault detection time and operate time of the trip contacts.

## 6.6 Directional power (ANSI 32)

### Description

The directional power function can be used, for example, to disconnect a motor if the supply voltage is lost and thus prevent power generation by the motor. It can also be used to detect loss of load of a motor.

The directional power function is sensitive to active power. For the directional power function, the start value is negative. For the underpower function, a positive start value is used. Whenever the active power goes under the start value, the stage starts and issues a start signal. If the fault situation stays on longer than the delay setting, a trip signal is issued.

The start setting range is from -200 % to +200 % of the nominal apparent power  $S_N$ . The nominal apparent power is determined by the configured voltage and current transformer values.

Equation 6.6:

$$S_n = VT_{Rated\ Primary} \cdot CT_{Rated\ Primary} \cdot \sqrt{3}$$

There are two identical stages available with independent setting parameters.

### Setting groups

There are four setting groups available for all stages.

### Characteristics

**Table 6.10: Directional power stages  $P<$ ,  $P<<$  (32)**

Input signal	$I_{L1} - I_{L3}$ $U_{L1} - U_{L3}$
Start value	-200.0 to +200.0 % $P_M$ (step 0.5)
Definite time function: - Operate time	0.3 – 300.0 s (step 0.1)
Start time	Typically 200 ms
Reset time	<500 ms
Reset ratio	1.05
Inaccuracy: - Starting - Operate time at definite time function	$\pm 3$ % of set value or $\pm 0.5$ % of rated value $\pm 1$ % or $\pm 150$ ms

**NOTE:** When the start setting is +1 to +200% ,an internal block is activated if the max. voltage of all phases drops below 5% of rated.



## 6.7 Phase undercurrent (ANSI 37)

### Description

The phase undercurrent stage measures the fundamental component of the phase currents.

The stage I< can be configured for definite time characteristic.

The undercurrent stage protects rather the relay driven by the motor, for example a submersible pump, than the motor itself.

### Setting groups

There are four setting groups available for each stage.

### Characteristics

**Table 6.11: Phase undercurrent I< (37)**

Input signal	$I_{L1} - I_{L3}$
Current setting range	20 – 70 % $I_{MOT}$ (step 1%)
Definite time characteristic: - operate time	0.3 – 300.0 s (step 0.1)
Block limit	15 % (fixed)
Start time	Typically 200 ms
Reset time	< 450 ms
Reset ratio	>1.05
Accuracy: - Starting - Operate time	$\pm 2\%$ of set value or $\pm 0.5\%$ of the rated value $\pm 1\%$ or $\pm 150$ ms

**NOTE:** Stage Blocking is functional when all phase currents are below the block limit.

## 6.8 Negative sequence overcurrent (ANSI 46)

### Description

Negative sequence overcurrent in a motor causes double frequency currents in the rotor. This warms up the surface of the rotor, and the available thermal capacity of the rotor is much less than the thermal capacity of the whole motor. Thus, RMS-current-based overload protection (see Chapter 6.11 Thermal overload (ANSI 49M)) is not capable of protecting a motor against negative sequence overcurrent. The negative sequence overcurrent protection is based on the negative sequence of the base frequency phase currents. Both definite time and dependent time characteristics are available.

### Dependent time delay

The dependent time delay is based on the following equation:

Equation 6.7:

$$T = \frac{K_1}{\left(\frac{I_2}{I_{MOT}}\right)^2 - K_2^2}$$

$T$  = Operate time  
 $K_1$  = Delay multiplier  
 $I_2$  = Measured and calculated negative sequence phase current of fundamental frequency.  
 $I_{MOT}$  = Nominal current of the motor  
 $K_2$  = Start setting  $I_2$  in pu. The maximum allowed degree of unbalance.

### Example

$$K_1 = 15 \text{ s}$$

$$I_2 = 22.9 \% = 0.229 \times I_{MOT}$$

$$K_2 = 5 \% = 0.05 \times I_{MOT}$$

$$t = \frac{15}{\left(\frac{0.229}{1}\right)^2 - 0.05^2} = 300.4$$

The operate time in this example is five minutes.

### More stages (definite time delay only)

If more than one definite time delay stages are needed for negative sequence overcurrent protection, the freely programmable stages

can be used (chapter Chapter 6.31 Programmable stages (ANSI 99)).

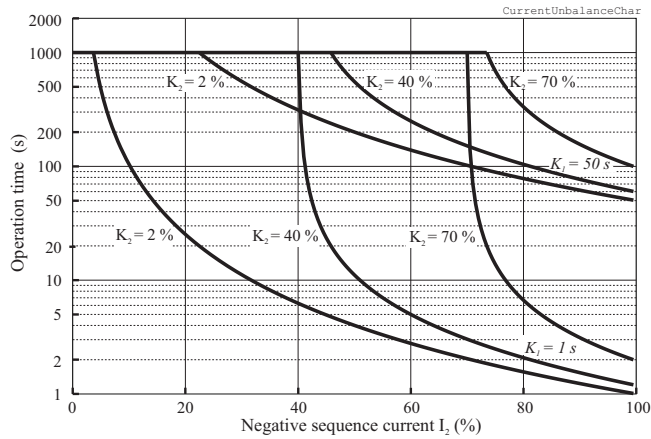

Figure 6.30: Dependent operation delay of negative sequence overcurrent  $I_{2>}$  (ANSI 46). The longest delay is limited to 1000 seconds (=16min 40s).

### Setting groups

There are four setting groups available.

### Characteristics

Table 6.12: Negative sequence overcurrent  $I_{2>}$  (46)

Input signal	$I_{L1} - I_{L3}$
Start value	2 – 70% (step 1%)
Definite time characteristic: - Operate time	1.0 – 600.0 s (step 0.1 s)
Dependent time characteristic: - 1 characteristic curve - Time multiplier - Upper limit for dependent time	Inv 1 – 50 s (step 1) 1000 s
Start time	Typically 300 ms
Reset time	< 450 ms
Reset ratio	<0.95
Inaccuracy: - Starting - Operate time	$\pm 1\%$ - unit $\pm 5\%$ or $\pm 200$ ms

**NOTE:** The stage is operational when all secondary currents are above 250 mA.

## 6.9 Incorrect phase sequence (ANSI 47)

### Description

The incorrect phase sequence detection prevents the motor from being started to wrong direction, thus protecting the load.

When the ratio between negative and positive sequence current exceeds 80% and the average of three phase currents exceeds  $0.2 \times I_{MOT}$  in the start-up situation, the phase sequence stage starts and trips 100 ms after start-up.

### Setting groups

This stage has one setting group.

### Characteristics

**Table 6.13: Incorrect phase sequence  $I_2 \gg$  (47)**

Input signal	$I_{L1} - I_{L3}$
Setting:	80 % (fixed)
Operate time	<120 ms
Reset time	< 105 ms

**NOTE:** Stage is blocked when motor has been running for 2 seconds.

Stage is operational only when least one of the currents is above  $0.2 \times I_{MOT}$

# 6.10 Motor start-up supervision (ANSI 48)

## Description

The motor start-up supervision stage protects the motor against prolonged direct-on-line (DOL) starts caused by, for example, a stalled rotor, too high inertia of the load or too low voltage. This function is sensitive to the fundamental frequency component of the phase currents.

Stage  $I_{ST}$  can be configured for definite time or dependent operate time characteristic.

The motor start-up supervision  $I_{ST}$  measures the fundamental frequency component of the phase currents.

The  $I_{ST}$  stage can be configured for definite operate time or dependent operate time characteristic. For a weak voltage supply, the dependent characteristic is useful allowing more start time when a voltage drop decreases the start current and increases the start time. Equation 6.8 defines the dependent operate time. Figure 6.31 shows an example of the dependent characteristic.

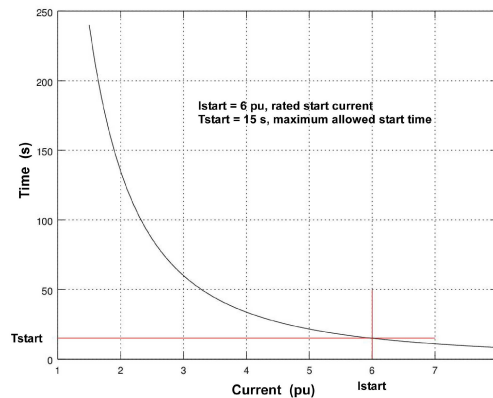

Figure 6.31: Example of an dependent operate time delay of the motor start-up supervision stage. If the measured current is less than the specified start current  $I_{START}$ , the operate time is longer than the specified start time  $T_{START}$  and vice versa.

Equation 6.8:

$$T = \left( \frac{I_{START}}{I_{MEAS}} \right)^2 T_{START}$$

- T = Dependent operate time
- $I_{START}$  = Rated start current of the motor “Nom motor start current”  $I_{MOTST}$ . The default setting is  $6.00 \times I_{MOT}$ .
- $I_{MEAS}$  = Measured current
- $T_{START}$  = Maximum allowed start time “Inv. time coefficient” k> for the motor at rated voltage.

The start setting “Motor start detection current”  $I_{ST}$  is the start detection level of the start current. While the current has been less than 10% of  $I_{MOT}$  and then within 200 milliseconds exceeds the setting  $I_{ST}$ , the motor start-up supervision stage starts to count the operate time  $T_{START}$ . When current drops below 120 % x  $I_{MOT}$ , the motor start-up supervision stage releases. Motor start-up supervision is active only during the starting of the motor.

### Block diagram

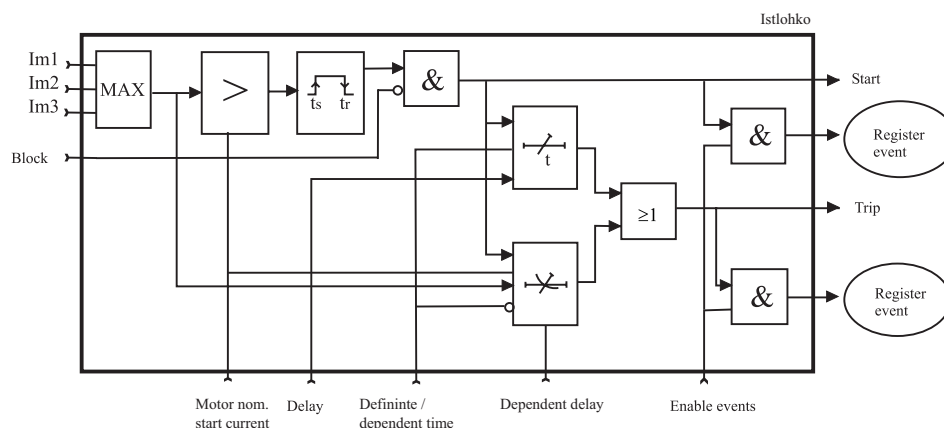

Figure 6.32: Block diagram of motor start-up supervision  $I_{ST}$

### Motor status view

There are three possible statuses for a motor: stopped, starting or running.

- Motor stopped: Motor average current is less than 10% of the motor nominal current.
- Motor starting: To reach the starting position, the motor has to be stopped for at least 500 ms before starting. The average motor current has to increase above the motor start detection current (setting value) within 200 ms. The motor remains starting as long as the terms for turning into running condition are not fulfilled.
- Motor running: The motor can change to the running position from both stopped and starting position. The low limit for motor running is 20% and the high limit 120% of the motors nominal current.



Figure 6.33: Motor status via Easergy Pro and local panel.

The motor status can be viewed via Easergy Pro software or via the relay's local panel (Mstat). The statuses starting and running can be found on the output and block matrix. Therefore, it is possible to use these signals for tripping or indication and for blocking purposes.

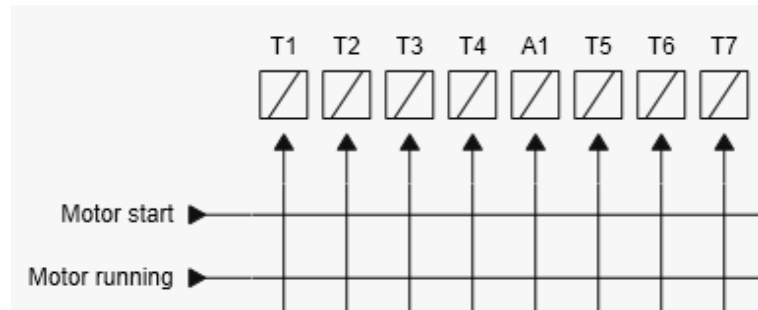

Figure 6.34: Motor status in output and block matrix

**Soft start**

Frequency converter drives and soft starter applications do not initiate the motor start signal due to the low current while starting motor. The motor changes directly from stopped to running position when the current increases to a certain level.

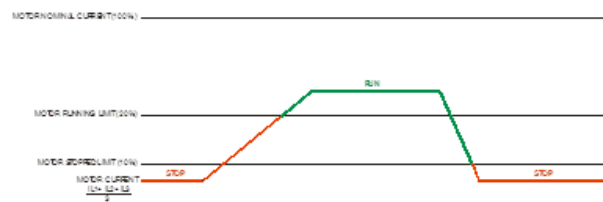

Figure 6.35: The terms of soft start

**Normal starting sequence**

As a default for the motor start detection, the relay uses a value that is six times the motor nominal value.

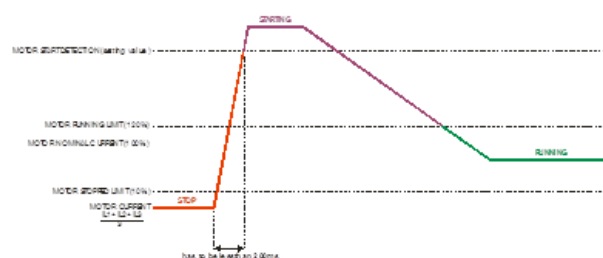

Figure 6.36: The terms of normal starting sequence

**Setting groups**

This stage has one setting group.

## Characteristics

**Table 6.14: Motor start-up supervision (48) in motor mode**

Input signal	$I_{L1} - I_{L3}$
Setting range: - Motor start detection current, $I_{ST}$ - Nominal motor start current, $I_{MOTST}$	1.30 – 10.00 x $I_{MOT}$ (step 0.01) 1.50 – 10.00 x $I_{MOT}$ (step 0.01)
Delay type	DT, INV
Definite time characteristic (DT): - operate time	1.0 – 300.0 s (step 0.1)**)
Dependent time characteristic (INV): - operate delay - dependent time coefficient, k	1.0 – 300.0 s (step 0.1) 1.0 – 200.0 s (step 0.1)
Minimum motor stop time to activate motor start-up supervision	500 ms
Maximum current raise time from motor stop to start	200 ms
Motor stopped limit	$0.10 \times I_{MOT}$
Motor running lower limit	$0.20 \times I_{MOT}$
Motor running limit after starting	$1.20 \times I_{MOT}$
Start time	Typically 60 ms
Reset time	<95 ms
Reset ratio	<0.95
Inaccuracy: - Starting - Operate time at definite time function - Operate time at IDMT function	$\pm 3\%$ of the set value or 5 mA secondary $\pm 1\%$ or at $\pm 30$ ms $\pm 5\%$ or at least $\pm 30$ ms

\*\*\*) This is the instantaneous time i.e. the minimum total operational time including the fault detection time and operation time of the trip contacts.

**NOTE:** Motor stopped and running limits are based on the average of three phase currents.



## 6.11 Thermal overload (ANSI 49M)

### Description

The thermal overload function protects the motor against excessive heating.

### Thermal model

The temperature is calculated using RMS values of phase currents and a thermal model according IEC60255-149. The RMS values are calculated using harmonic components up to the 15th.

$$\text{Trip time: } t = \tau \cdot \ln \frac{I^2 - I_P^2}{I^2 - a^2}, \quad \tau \text{ unit: second}$$

$$\text{Alarm: } a = k \cdot k_{\Theta} \cdot I_{MOT} \cdot \sqrt{alarm} \quad (\text{alarm } 60\% = 0.6)$$

$$\text{Trip: } a = k \cdot k_{\Theta} \cdot I_{MOT}$$

$$\text{Reset time: } t = \tau \cdot C_{\tau} \cdot \ln \frac{I_P^2}{a^2 - I^2}, \quad \tau \text{ unit: second}$$

$$\text{Trip release: } a = \sqrt{0.95} \times k \times I_{MOT}$$

$$\text{Start release: } a = \sqrt{0.95} \times k \times I_{MOT} \times \sqrt{alarm} \quad (\text{alarm } 60\% = 0.6)$$

T = Operate time

$\tau$  = Thermal time constant tau (setting value)

ln = Natural logarithm function

I = Measured RMS phase current (the max. value of three phase currents)

I<sub>p</sub> = Preload current,  $I_P = \sqrt{\theta} \times k \times I_{MOT}$  (If temperature rise is 120% ->  $\theta = 1.2$ ). This parameter is the memory of the algorithm and corresponds to the actual temperature rise.

k = Overload factor (Maximum continuous current), i.e. service factor (setting value).

k<sub>Θ</sub> = Ambient temperature factor (permitted current due to t<sub>amb</sub>).

I<sub>MOT</sub> = The rated current of the motor

$C_r =$  Relay cooling time constant (setting value)

### Time constant for cooling situation

If the motor's fan is stopped, the cooling is slower than with an active fan. Therefore, there is a coefficient  $C_T$  for thermal constant available to be used as cooling time constant when the current is less than  $0.3 \times I_{MOT}$ .

### Heat capacitance, service factor and ambient temperature

The trip level is determined by the maximum allowed continuous current  $I_{MAX}$  corresponding to the 100 % temperature rise  $\Theta_{TRIP}$  for example the heat capacitance of the motor.  $I_{MAX}$  depends on the given service factor  $k$  and ambient temperature  $\Theta_{AMB}$  and settings  $I_{MAX40}$  and  $I_{MAX70}$  according to the following equation.

$$I_{MAX} = k \cdot k_{\Theta} \cdot I_{MOT}$$

The value of ambient temperature compensation factor  $k_{\Theta}$  depends on the ambient temperature  $\Theta_{AMB}$  and settings  $I_{MAX40}$  and  $I_{MAX70}$ . See Figure 6.37. Ambient temperature is not in use when  $k_{\Theta} = 1$ . This is true when

- $I_{MAX40}$  is 1.0
- $S_{amb}$  is "n/a" (no ambient temperature sensor)
- $\Theta_{AMB}$  is +40 °C.

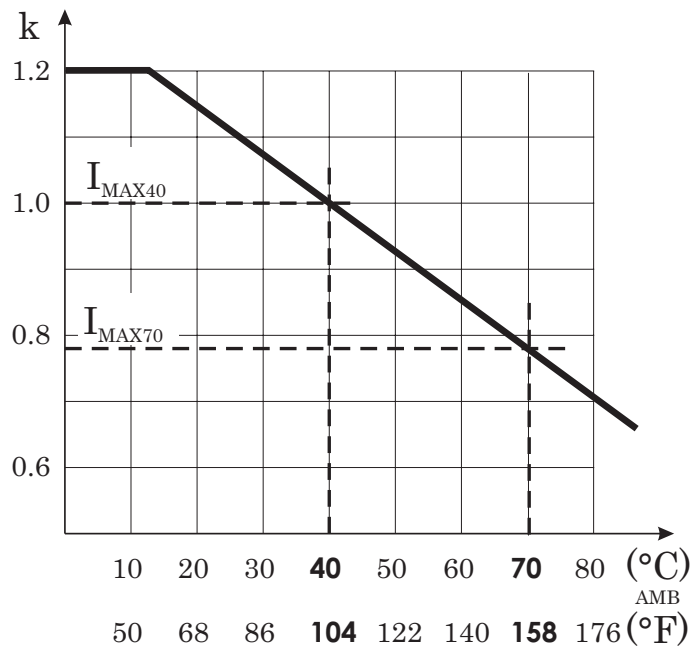

Figure 6.37: Ambient temperature correction of the overload stage  $T >$

### Example of the thermal model behaviour

Figure 6.37 shows an example of the thermal model behaviour. In this example  $\tau = 30$  minutes,  $k = 1.06$  and  $k\Theta = 1$  and the current has been zero for a long time and thus the initial temperature rise is 0 %. At time = 50 minutes the current changes to  $0.85 \times I_{MOT}$  and the temperature rise starts to approach value  $(0.85/1.06)^2 = 64$  % according to the time constant. At time = 300 min, the temperature is nearly stable, and the current increases to 5 % over the maximum defined by the rated current and the service factor  $k$ . The temperature rise starts to approach value 110 %. At about 340 minutes, the temperature rise is 100 % and a trip follows.

### Initial temperature rise after restart

When the relay is switched on, an initial temperature rise of 70 % is used. Depending on the actual current, the calculated temperature rise then starts to approach the final value.

### Alarm function

The thermal overload stage is provided with a separately settable alarm function. When the alarm limit is reached, the stage activates its start signal.

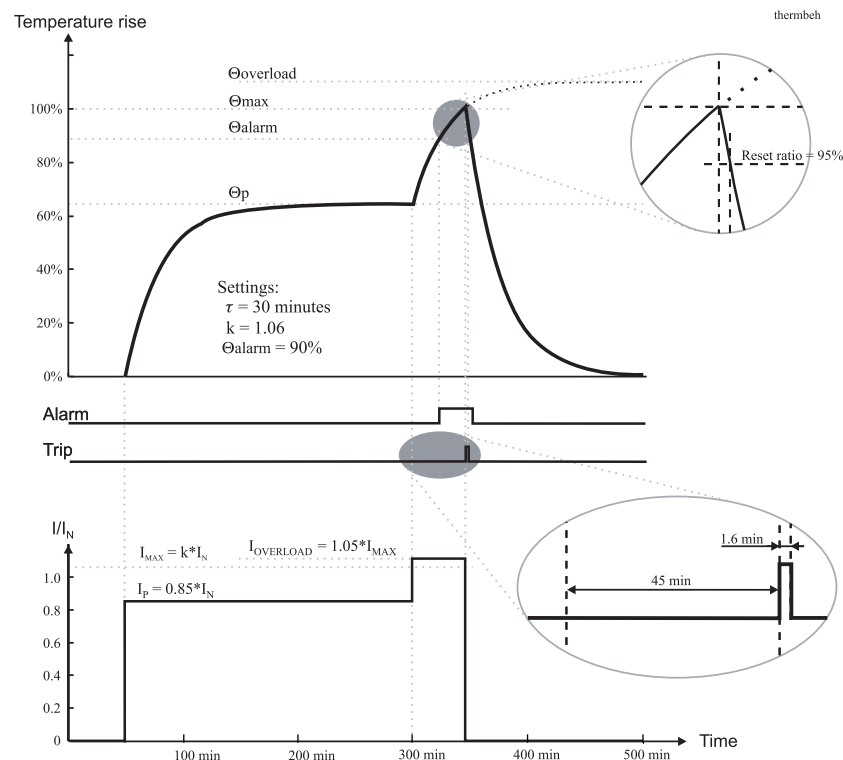

Figure 6.38: Example of the thermal model behaviour.

### Setting groups

This stage has one setting group.

## Characteristics

**Table 6.15: Thermal overload (49M)**

Input signal	$I_{L1} - I_{L3}$
Maximum continuous current	$0.1 - 2.40 \times I_{MOT}$
Alarm setting range	60 – 99 % (step 1%)
Time constant $\tau$	2 – 180 min (step 1)
Cooling time coefficient	$1.0 - 10.0 \times \tau$ (step 0.1)
Max. overload at +40°C	$70 - 120 \% I_{MOT}$ (step 1)
Max. overload at +70°C	$50 - 100 \% I_{MOT}$ (step 1)
Ambient temperature	-55 – 125°C (step 1°)
Reset ratio (Start & trip)	0.95
Operate time inaccuracy	Relative inaccuracy $\pm 5\%$ or absolute inaccuracy 1 s of the theoretical value

## 6.12 Phase overcurrent (ANSI 50/51)

### Description

Phase overcurrent protection is used against short-circuit faults and heavy overloads.

The overcurrent function measures the fundamental frequency component of the phase currents. The protection is sensitive to the highest of the three phase currents. Whenever this value exceeds the user's start setting of a particular stage, this stage starts and a start signal is issued. If the fault situation remains on longer than the operation delay setting, a trip signal is issued.

### Block diagram

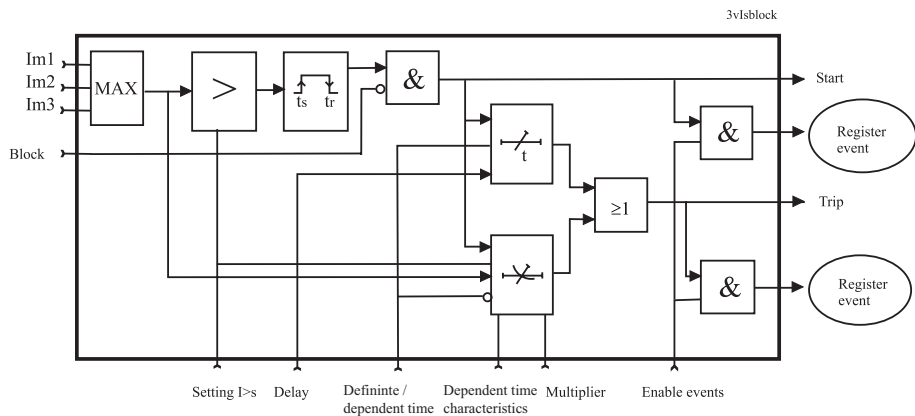

Figure 6.39: Block diagram of the three-phase overcurrent stage I>

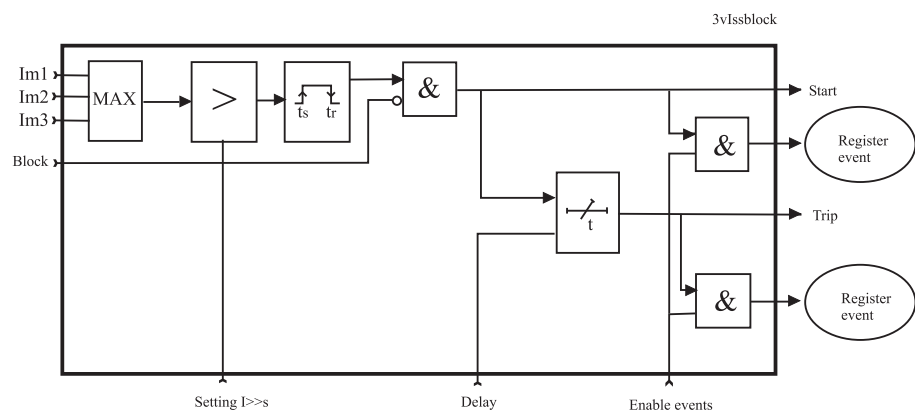

Figure 6.40: Block diagram of the three-phase overcurrent stage I>> and I>>>

### Three independent stages

There are three separately adjustable overcurrent stages: I>, I>> and I>>>. The first stage I> can be configured for definite time (DT) or dependent operate time (IDMT) characteristic. The stages I>> and I>>> have definite time operation characteristic. By using the definite delay type and setting the delay to its minimum, an instantaneous (ANSI 50) operation is obtained.

---

Figure 6.39 shows a functional block diagram of the I> overcurrent stage with definite time and dependent time operate time. Figure 6.40 shows a functional block diagram of the I>> and I>>> overcurrent stages with definite time operation delay.

### Dependent operate time

Dependent operate time means that the operate time depends on the amount the measured current exceeds the start setting. The bigger the fault current is, the faster is the operation. The dependent time delay types are described in Chapter 6.3 Dependent operate time. The relay shows the currently used dependent operate time curve graph on the local panel display.

### Dependent time limitation

The maximum measured secondary current is  $50 \times I_N$ . This limits the scope of *dependent curves* with high start settings. See Chapter 6.3 Dependent operate time for more information.

### Include harmonics setting

The I> and I>> (50/51) overcurrent protection stages have a setting parameter to include harmonics. When this setting is activated, the overcurrent stage calculates the sum of the base frequency and all measured harmonics. This feature is used to determine the signal's true root mean square value to detect the signal's real heating factor. The operate time is 5 ms more when harmonics are included in the measurement. Activate the "Include harmonics" setting if the overcurrent protection is used for thermal protection and the content of the harmonics is known to exist in the power system.

### Cold load and inrush current handling

See Chapter 7.3 Cold load start and magnetising inrush.

### Setting groups

There are four setting groups available for each stage.

## Characteristics

**Table 6.16: Phase overcurrent stage I> (50/51)**

Input signal	$I_{L1} - I_{L3}$
Start value	0.05 – 5.00 $\times I_{MOT}$ (step 0.01)
Definite time function: - Operate time	DT** 0.04 – 300.00 s (step 0.01 s)
IDMT function: - Delay curve family - Curve type - Inv. time coefficient k	(DT), IEC, IEEE, RI Prg EI, VI, NI, LTI, MI..., depends on the family* 0.025 – 20.0, except 0.50 – 20.0 for RXIDG, IEEE and IEEE2
Start time	Typically 30 ms
Reset time	<95 ms
Overshoot time	< 50 ms
Reset ratio	<0.97
Transient overreach, any $\tau$	< 10 %
Inaccuracy: - Starting - Operate time at definite time function - Operate time at IDMT function	$\pm 3\%$ of the set value or 5 mA secondary $\pm 1\%$ or $\pm 25$ ms $\pm 5\%$ or at least $\pm 25$ ms**

**Table 6.17: Phase overcurrent stage I>> (50/51)**

Input signal	$I_{L1} - I_{L3}$
Start value	0.10 – 20.00 $\times I_{MOT}$ (step 0.01)
Definite time function: - Operate time	DT** 0.04 – 1800.00 s (step 0.01 s)
Start time	Typically 30 ms
Reset time	<95 ms
Overshoot time	< 50 ms
Reset ratio	<0.97
Transient overreach, any $\tau$	< 10 %
Inaccuracy: - Starting - operate time	$\pm 3\%$ of the set value or 5 mA secondary $\pm 1\%$ or $\pm 25$ ms

**Table 6.18: Phase overcurrent stage I>>> (50/51)**

Input signal	$I_{L1} - I_{L3}$
Start value	0.10 – 40.00 $\times I_{MOT}$ (step 0.01)
Definite time function: - Operate time	DT** 0.03 – 300.00 s (step 0.01 s)
Instant operate time: $I_M / I_{SET}$ ratio > 1.5 $I_M / I_{SET}$ ratio 1.03 – 1.5	<30 ms < 50 ms
Start time	Typically 20 ms
Reset time	<95 ms
Overshoot time	< 50 ms
Reset ratio	0.97
Inaccuracy: - Starting - Operate time DT ( $I_M / I_{SET}$ ratio > 1.5) - Operate time DT ( $I_M / I_{SET}$ ratio 1.03 – 1.5)	$\pm 3\%$ of the set value or 5 mA secondary $\pm 1\%$ or $\pm 15$ ms $\pm 1\%$ or $\pm 25$ ms

\*) EI = Extremely Inverse, NI = Normal Inverse, VI = Very Inverse, LTI = Long Time Inverse, MI = Moderately Inverse

\*\*\*) This is the instantaneous time i.e. the minimum total operational time including the fault detection time and operate time of the trip contacts.



## 6.13 Breaker failure 1 (ANSI 50BF)

### Description

The circuit breaker failure protection stage (CBFP) can be used to operate any upstream circuit breaker (CB) if the programmed output matrix signals, selected to control the main breaker, have not disappeared within a given time after the initial command. The supervised output contact is defined by the “Monitored Trip Relay” setting. An alternative output contact of the relay must be used for this backup control selected in the OUTPUT MATRIX setting view. The CBFP operation is based on the supervision of the signal to the selected output contact and the time. The following output matrix signals, when programmed into use, start the CBFP function:

- protection functions
- control functions
- supporting functions
- GOOSE signals (through communication)

If the signal is longer than the CBFP stage’s operate time, the stage activates another output contact defined in the OUTPUT MATRIX setting view. The output contact remains activated until the signal resets. The CBFP stage supervises all the signals assigned to the same selected output contact.

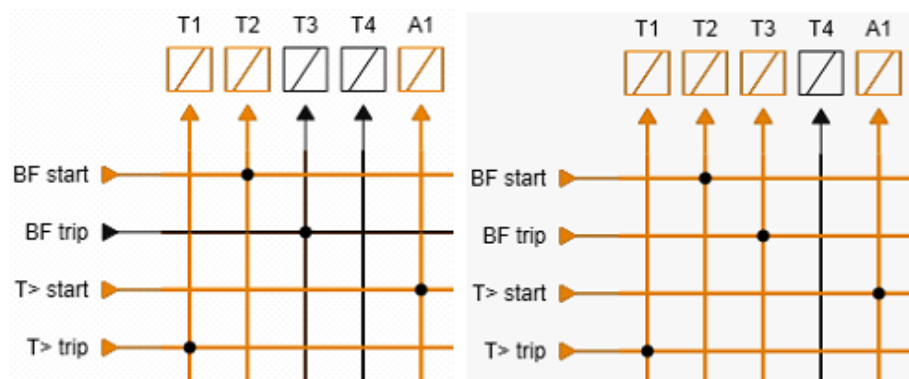

Figure 6.41: Both the trip and CBFP start signals activate simultaneously (left picture). If T> trip fails to control the CB through T1, the CBFP activates T3 after the breaker failure operate time.

**NOTE:** For the CBFP, always select the “Connected” crossing symbol in the OUTPUT MATRIX setting view.

## Characteristics

**Table 6.19: Breaker failure (50BF)**

Relay to be supervised	T1 – T4 (depending on the order code)
Definite time function: - Operate time	0.1** – 10.0 s (step 0.1 s)
Inaccuracy: - Operate time	±20 ms

\*\* ) This is the instantaneous time i.e. the minimum total operational time including the fault detection time and operate time of the trip contacts.

## 6.14 Breaker failure 2 (ANSI 50BF)

### Description

Power system protection should always have some sort of backup protection available. Backup protection is intended to operate when a power system fault is not cleared or an abnormal condition is not detected in the required time because of a failure or the inability of the primary protection to operate or failure of the appropriate circuit breakers to trip. Backup protection may be local or remote.

Circuit breaker failure protection (CBFP) is part of the local backup protection. CBFP provides a backup trip signal to an upstream circuit breaker (CB) when the CB nearest to fault fails to clear fault current. The CB may fail to operate for several reasons, for example burnt open coil or a flashover in the CB.

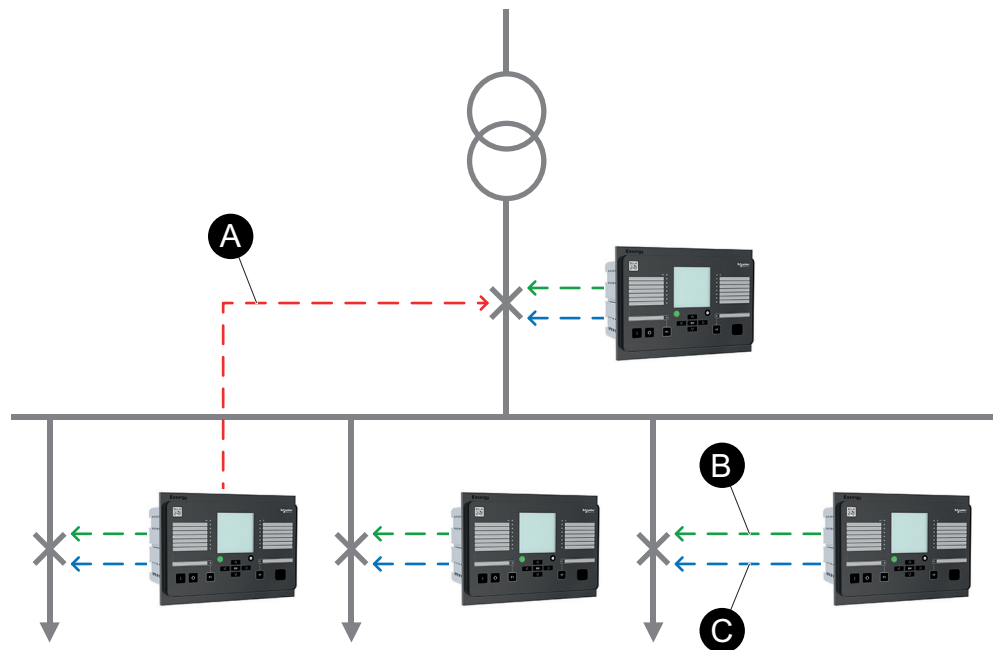

- A. CBFP trip
- B. Normal trip
- C. Re-trip

Figure 6.42: CBFP implementation

Two separate stages are provided to enable re-trip and CBFP trip commands. The first stage can be used to give re-trip command (for example to control second/backup open coil of the main CB) while the second stage can give dedicated CBFP trip command to an upstream circuit breaker. Select the required outputs for re-trip and CBFP trip through the output matrix.

### Block diagram

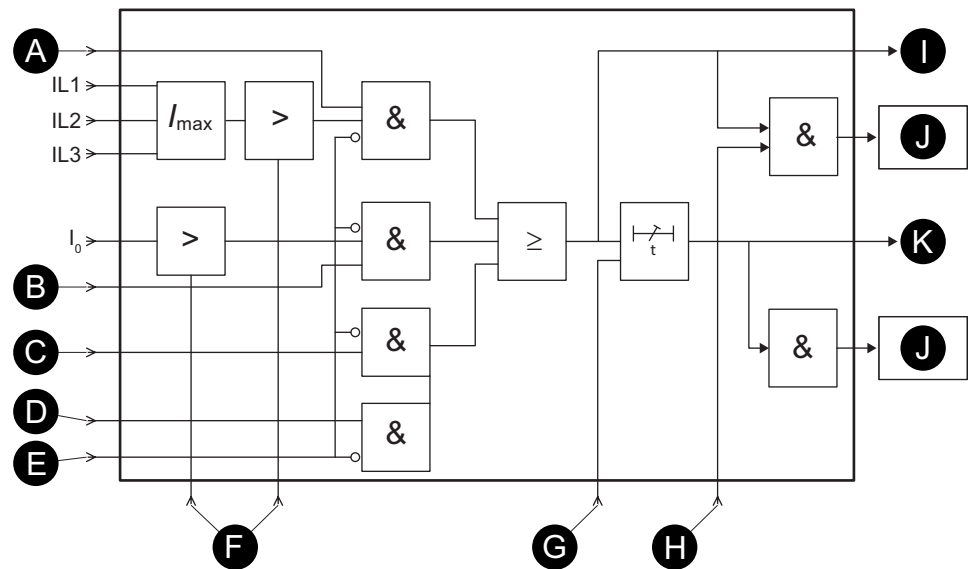

A.	Condition 1	G.	Delay setting
B.	Condition 2	H.	Enable events setting
C.	Condition 3	I.	Start
D.	Condition 4	J.	Event register
E.	Block	K.	Trip
F.	Zero-current setting		

Figure 6.43: Breaker failure 2 operation

### CBFP operation

The CBFP function can be enabled and disabled with the **Enable for BF2** selection. The CBFP function activates when any of the selected start signals becomes and stays active.

The CBFP operation can be temporarily blocked by the stage block signal from the block matrix. When the stage is blocked by the block signal, the stage timer stops but it does not reset. The stage timer continues its operation when the block signal is disabled. When the block signal is active, the stage output signals are disabled.

The CBFP stage provides the following events:

- start on
- start off
- trip on
- trip off

Events can be activated via the **Enable events** setting view.

### Condition selectors

The CBFP function has four condition selectors that can be used separately or all together to activate and reset the CBFP function.

The four condition selectors are almost identical. The only difference is that condition selectors 1 and 2 are for all protection functions that benefit from zero-current detection for resetting the CBFP as described in section Zero-current detector, and selectors 3 and 4 are for all the protection functions that do not benefit from zero-current detection for CBFP.

Condition selector 4 can be used to support selectors 1, 2 and 3. For example, if there are too many stages to be monitored in condition set 1, condition selector 4 can be used to monitor the output contacts. Monitoring digital inputs is also possible if the backup protection is based on external current relay, for example. The only CBFP reset criteria for condition set 4 are the monitored input and output signals.

**Condition 1**

State inactive

Enable monitoring DI1

Monitored protection stage |>

Monitored protection stage |>>

Monitored protection stage |>>>

Monitored protection stage -

Monitored protection stage -

Monitored protection stage -

**Reset condition 1**

Reset by CB status -

Reset by monitored stage

Reset by zero current

Figure 6.44: Start signal and reset condition setting view for Condition 1

Separate zero-current detection with dedicated start settings exists for phase overcurrent and earth fault overcurrent signals. Zero-current detection is independent of the protection stages.

The condition criteria, available signals and reset conditions are listed in Table 6.20.

**NOTE:** The start signal can be selected for each condition in advance from the pull-down menu even if the concerned stage is not enabled. For the CBFP activation, the concerned stage must be enabled from the protection stage menu and the stage has to start to activate the CBFP start signal.

Table 6.20: CBFP condition selectors

Criteria	Start signal	Reset condition
Condition 1	I>, I>>, I>>>, Iv>, I2>, dl>, dl>>, Iφ>, Iφ>>, Iφ>>>, Iφ>>>>, T>, If2>, X<, X<<, I'>, I'>>, If5, SOTF	<b>Reset by CB status:</b> DI1 – Dlx (1, F1, F2, VI1-20, VO1–20, GOOSE_NI1–64, POC1–16, Obj1-8Op
Condition 2	Io>, Io>>, Io>>>, Io>>>>, Io>>>>>, Ioφ>, Ioφ>>, Ioφ>>>, dIo>, dIo>>	<b>Monitored stage:</b> On/Off <b>Zero-current detection:</b> On/Off
Condition 3	Uof3<, U>, U>>, U>>>, U<, U<<, U<<<, U1<, U1<<, Uo>, Uo>>, P<, P<<, Q<, Z<, Z<<, Pgr1-8, f<, f<<, fx, fxx, df/dt, Uf>, Pslip	<b>Reset by CB status:</b> DI1 – Dlx (1, F1, F2, VI1-20, VO1–20, GOOSE_NI1–64, POC1–16, Obj1-8Op <b>Monitored stage:</b> On/Off
Condition 4	Outputs: A1, T1-Tx (1) Inputs: DI1 – Dlx (1, F1, F2, VI1-20, VO1 – 20, GOOSE_NI1 – 64, POC1 – 16 Arc sensor 3- 10, ArcStg1-8, I>int, Io>int	<b>Monitored stage:</b> On/Off

In addition to the selection of the start signal, the CBFP reset condition needs to be selected.

If no reset conditions are selected, the stage uses **Reset by monitored stage** as the reset condition. This prevents a situation where the stage never releases.

The reset condition **Reset by CB status** is useful if the current is already zero when the CB is opened (for example unloaded CB).

When more than one selection criteria are selected, AND condition is used, for example “zero current detection” AND “object open”. See Figure 6.43 for details.

### Stage timer

The operate delay timer is started by a signal activated by the monitored stages (condition selectors). The operate time delay is a settable parameter. When the given time delay has elapsed, the stage provides a trip signal through the output matrix and the event codes.

The timer delay can be set between 40 and 200 ms.

### Zero-current detector

The zero-current detector is an undercurrent condition to reset the CBFP function when all phase currents are below the start (pick-up) setting value. This separate undercurrent condition is needed to properly detect successful CB operation. For example, in a CB failure condition where one or more CB poles are partly conducting when the CB is open, the fault current can be small enough to reset the primary protection stage (for example overcurrent stage), in which case the CBFP does not operate. When a separate undercurrent limit is used, CBFP reset can be performed only when the fault current really is zero or near zero instead of relying on the protection stage reset.

Breaker failure 2		50BF	
Enable for BF2	<input type="checkbox"/>		
Status	-		
Start counter	0	<input type="button" value="Clear"/>	
Trip counter	0	<input type="button" value="Clear"/>	
Zero current detection			
Max. of IL1 IL2 IL3	0	A	
Pick-up setting	100	A	
Pick-up setting	<input type="range" value="0.10"/>	0.10	xIn
Zero E-F current detection			
Io1 residual current	0.000	pu	
Io input	Io1		
Pick-up setting	0.50	A	
Pick-up setting	<input type="range" value="0.050"/>	0.050	pu

Figure 6.45: Zero-current detector setting view

The setting range of the zero-current detector is always associated with the CT nominal value, even in case of motor and transformer protection. The setting range minimum depends on the relay accuracy. Instead of zero, a small minimum value can be accepted. See Table 6.21.

### CBFP coordination

The CBFP delay setting has to be coordinated according to the CB operation time and the reset time of protection stages monitored by the CBFP function as described in Figure 6.46.

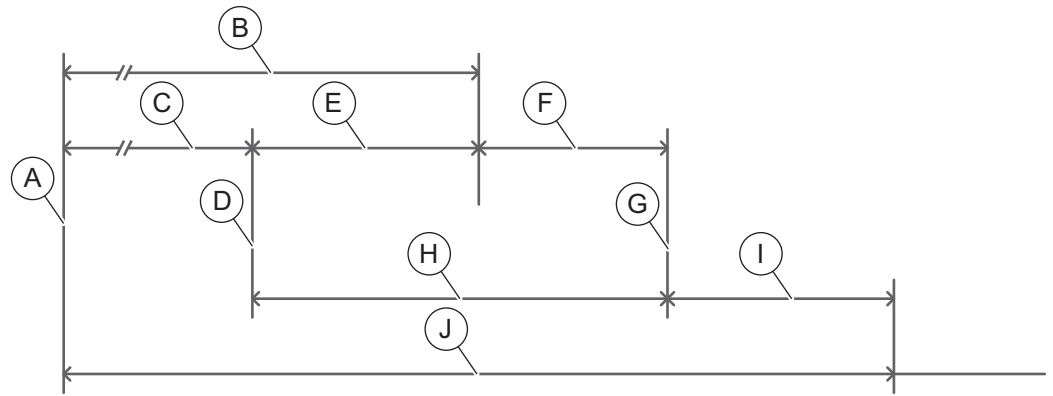

- A. Fault occurrence
- B. Normal fault clearing time
- C. Protection delay
- D. CBFP stage start
- E. CB operate time
- F. Protection stage reset time + safety margin
- G. CBFP trip
- H. CBFP stage operate delay (CB operate time + protection stage reset time + safety margin)
- I. CB operate time
- J. Total fault clearing time in case of failed CB operation but successful CBFP operation

Figure 6.46: CBFP coordination

### Characteristics

Table 6.21: Breaker failure 2 (ANSI 50BF)

Zero-current detection:	
- Phase overcurrent	0.05–0.2 x I <sub>n</sub>
- Earth fault overcurrent	0.005–20 x p.u.
Definite time function:	
- Operate time	0.04–0.2 s
Inaccuracy:	
- Operate time	±20 ms



## 6.15 Switch-onto-fault (ANSI 50HS)

### Description

The switch-onto-fault (SOTF) protection function offers fast protection when the circuit breaker (CB) is closed manually against a faulty line. Overcurrent-based protection does not clear the fault until the intended time delay has elapsed. SOTF gives a trip signal without additional time delay if the CB is closed and a fault is detected after closing the CB.

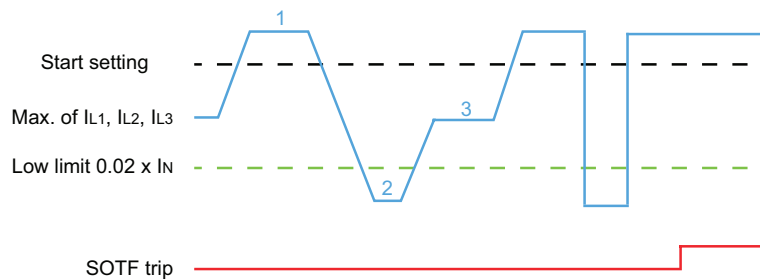

Figure 6.47: Switch-onto-fault function operates when the CB has detected open and the fault current reaches start setting value.

1. Switch-onto-fault does not activate if the CB has not been in open position before the fault. Open CB detection is noticed from the highest phase current value which has to be under a fixed low-limit threshold ( $0.02 \times I_N$ ). Opening of the CB can be detected also with digital inputs (Dead line detection input = DI1 – DIx, VI1 – VIx). The default detection input is based on the current threshold, so the dead line detection input parameter has value “\_”.
2. Dead line detection delay defines how long the CB has to be open so that the SOTF function is active. If the set time delay is not fulfilled and the highest phase current value (maximum of  $I_{L1}$ ,  $I_{L2}$ ,  $I_{L3}$ ) rises over the start setting, the SOTF does not operate.
3. If the highest phase current value of  $I_{L1}$ ,  $I_{L2}$ ,  $I_{L3}$  goes successfully under the low limit and rises to a value between the low limit and the start value, then if the highest phase current value rises over the start setting value before the set SOTF active after CB closure time delay has elapsed, the SOTF trips. If this time delay is exceeded, the SOTF does not trip even if the start setting value is exceeded.

### Setting groups

This stage has one setting group.

## Characteristics

**Table 6.22: Switch-onto-fault SOTF (50HS)**

Start value	1.00 – 3.00 x $I_N$ (step 0.01)
Dead line detection delay	0.00 – 60.00 s (step 0.01)
SOTF active after CB closure	0.10 – 60.00 s (step 0.01)
Operate time	< 30 ms (When $I_M/I_{SET}$ ratio > 1.5)
Reset time	< 95 ms
Reset ratio	<0.97
Inaccuracy	±3% of the set value or 5 mA secondary

# 6.16 Earth fault overcurrent (ANSI 50N/51N)

## Description

The purpose of the unidirectional earth fault overcurrent protection is to detect earth faults in low-impedance earthed networks. In high-impedance earthed networks, compensated networks and isolated networks, unidirectional earth fault overcurrent can be used as backup protection.

The unidirectional earth fault overcurrent function is sensitive to the fundamental frequency component of the earth fault overcurrent  $3I_0$ . The attenuation of the third harmonic is more than 60 dB. Whenever this fundamental value exceeds the start setting of a particular stage, this stage starts and a start signal is issued. If the fault situation remains on longer than the operate time delay setting, a trip signal is issued.

## Block diagram

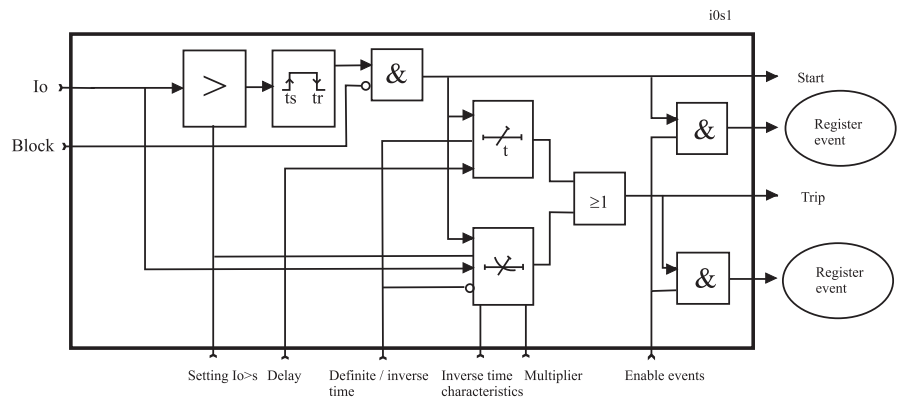

Figure 6.48: Block diagram of the earth fault stage overcurrent  $I_0>$

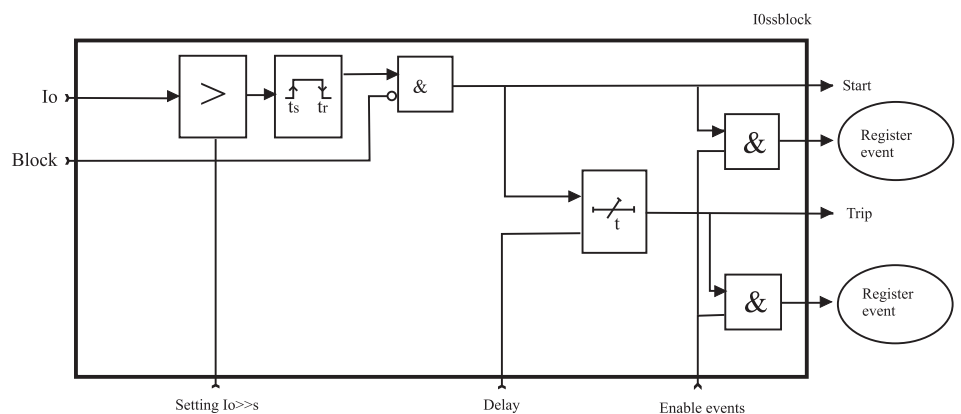

Figure 6.49: Block diagram of the earth fault stages overcurrent  $I_0>>$ ,  $I_0>>>$ ,  $I_0>>>>$

### Input signal selection

Each stage can be connected to supervise any of the following inputs and signals:

- Input  $I_{01}$  for all networks other than solidly earthed.
- Input  $I_{02}$  for all networks other than solidly earthed.
- Calculated signal  $I_{0Calc}$  for solidly and low-impedance earthed networks.  $I_{0Calc} = I_{L1} + I_{L2} + I_{L3}$ .

### Four or six independent unidirectional earth fault overcurrent stages

There are four separately adjustable earth fault overcurrent stages:  $I_{0>}$ ,  $I_{0>>}$ ,  $I_{0>>>}$ , and  $I_{0>>>>}$ . The first stage  $I_{0>}$  can be configured for definite time (DT) or dependent time operation characteristic (IDMT). The other stages have definite time operation characteristic. By using the definite delay type and setting the delay to its minimum, an instantaneous (ANSI 50N) operation is obtained.

Using the directional earth fault overcurrent stages (Chapter 6.23 Directional earth fault overcurrent (ANSI 67N)) in unidirectional mode, two more stages with dependent operate time delay are available for unidirectional earth fault overcurrent protection.

### Dependent time limitation

The maximum measured secondary earth fault overcurrent is  $10 \times I_{0N}$  and the maximum measured phase current is  $50 \times I_N$ . This limits the scope of dependent curves with high start settings.

### Setting groups

There are four setting groups available for each stage.

## Characteristics

**Table 6.23: Earth fault overcurrent  $I_0 >$  (50N/51N)**

Input signal	$I_{01}, I_{02}$ $I_{0Calc} (= I_{L1} + I_{L2} + I_{L3})$
Start value	0.005–8.00 pu (when $I_{01}$ or $I_{02}$ ) (step 0.001) 0.05–20.0 pu (when $I_{0Calc}$ )
Definite time function: - Operate time	DT** 0.04** – 300.00 s (step 0.01 s)
IDMT function: - Delay curve family - Curve type - Inv. time coefficient k	(DT), IEC, IEEE, RI Prg EI, VI, NI, LTI, MI..., depends on the family* 0.025–20.0, except 0.50–20.0 for RXIDG, IEEE and IEEE2
Start time	Typically 30 ms
Reset time	<95 ms
Reset ratio	<0.95
Inaccuracy: - Starting - Starting (Peak mode)  - Operate time at definite time function - Operate time at IDMT function	$\pm 2\%$ of the set value or $\pm 0.3\%$ of the rated value $\pm 5\%$ of the set value or $\pm 2\%$ of the rated value (Sine wave <65 Hz)  $\pm 1\%$ or $\pm 25$ ms $\pm 5\%$ or at least $\pm 25$ ms**

**Table 6.24: Earth fault overcurrent  $I_0 >>$ ,  $I_0 >>>$ ,  $I_0 >>>>$  (50N/51N)**

Input signal	$I_{01}, I_{02}$ $I_{0Calc} (= I_{L1} + I_{L2} + I_{L3})$
Start value	0.01–8.00 pu (When $I_{01}$ or $I_{02}$ ) (step 0.01) 0.05–20.0 pu (When $I_{0Calc}$ ) (step 0.01)
Definite time function: - Operate time	0.04** – 300.00 s (step 0.01 s)
Start time	Typically 30 ms
Reset time	<95 ms
Reset ratio	<0.95
Inaccuracy: - Starting - Starting (Peak mode)  - Operate time	$\pm 2\%$ of the set value or $\pm 0.3\%$ of the rated value $\pm 5\%$ of the set value or $\pm 2\%$ of the rated value (Sine wave <65 Hz)  $\pm 1\%$ or $\pm 25$ ms

\*) EI = Extremely Inverse, NI = Normal Inverse, VI = Very Inverse, LTI = Long Time Inverse, MI= Moderately Inverse

\*\*\*) This is the instantaneous time i.e. the minimum total operational time including the fault detection time and operation time of the trip contacts.

### 6.16.1

## Earth fault faulty phase detection algorithm

The earth fault overcurrent stage (ANSI 50N/51N) and directional earth fault overcurrent stage (ANSI 67N) have an inbuilt detection algorithm to detect a faulty phase. This algorithm is meant to be used

---

in radial-operated distribution networks. The faulty phase detection can be used in solidly-earthed, impedance-earthed or resonant-earthed networks.

### Operation

The faulty phase detection starts from the earth fault stage trip. At the moment of stage start, the phase currents measured prior to start are registered and stored as prior-to-fault currents. At the moment of trip, phase currents are registered again. Finally, faulty phase detection algorithm is performed by comparing prior-to-fault currents to fault currents. The algorithm also uses positive sequence current and negative sequence current to detect faulty phase.

The detection algorithm can be enabled and disabled by selecting or unselecting a checkbox in the protection stage settings. Correct network earthing configuration must be selected in the stage settings, too. In the earth fault overcurrent stage settings, you can select between RES and CAP network earthing configuration. This selection has no effect on the protection itself, only on the faulty phase detection. In the directional earth fault overcurrent stage settings, the detection algorithm uses the same network earthing type as selected for protection. RES is used for solidly-earthed, impedance-earthed and resonant-earthed networks. CAP is only used for isolated networks.

The detected faulty phase is registered in the protection stage fault log (and also in the event list and alarm screen). Faulty phase is also indicated by a line alarm and line fault signals in the output matrix. Possible detections of faulty phases are L1-N, L2-N, L3-N, L1-L2-N, L1-L3-N, L2-L3-N, L1-L2-L3-N, and REV. If the relay protection coordination is incorrect, REV indication is given in case of a relay sympathetic trip to a reverse fault.

# 6.17 Capacitor bank unbalance (ANSI 51C)

**NOTE:** Configure the capacitor bank unbalance protection through the earth fault overcurrent stages I<sub>0</sub>>>> and I<sub>0</sub>>>>>.

### Description

The relay enables capacitor, filter and reactor bank protection with its five current measurement inputs. The fifth input is typically useful for unbalance current measurement of a double-wye connected unearthened bank.

The unbalance protection is highly sensitive to internal faults of a bank because of the sophisticated natural unbalance compensation. The location method enables easy maintenance monitoring for a bank.

This protection scheme is specially used in double-wye-connected capacitor banks. The unbalance current is measured with a dedicated current transformer (like 5A/5A) between two starpoints of the bank. As the capacitor elements are not identical and have acceptable tolerances, there is a natural unbalance current between the starpoints of the capacitor banks. This natural unbalance current can be compensated to tune the protection sensitive against real faults inside the capacitor banks.

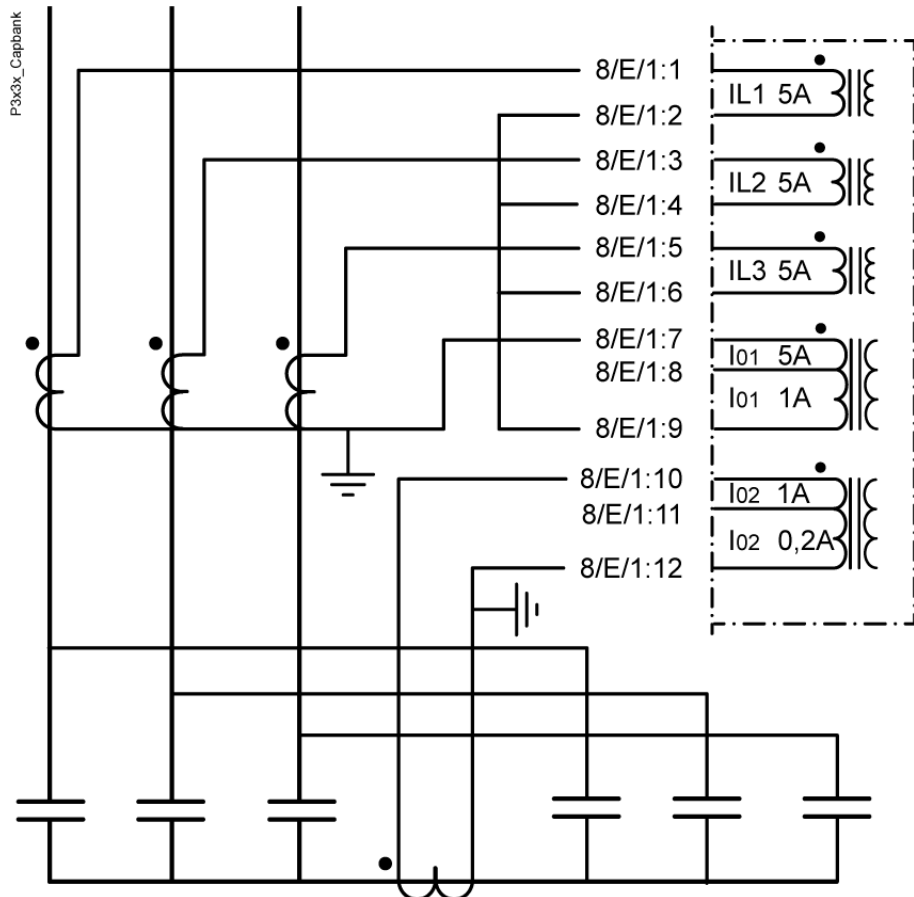

Figure 6.50: Typical capacitor bank protection application with Easergy P3 relays

### Compensation method

The method of unbalance protection is to compensate for the natural unbalance current. The compensation is triggered manually when commissioning. The phasors of the unbalance current and one phase current are then recorded. This is because one polarizing measurement is needed. When the phasor of the unbalance current is always related to  $I_{L1}$ , the frequency changes or deviations have no effect on the protection. After the recording, the measured unbalance current corresponds to the zero-level and therefore, the setting of the stage can be very sensitive.

### Compensation and location

The most sophisticated method is to use the compensation method described above with an add-on feature that locates the branch of each faulty element (the broken fuse).

This feature is implemented to the stage  $I_{0>>>>}$ , while the other stage  $I_{0>>>}$  can still function as normal unbalance protection stage with the compensation method. Normally, the  $I_{0>>>>}$  could be set as an alarming stage while stage  $I_{0>>>}$  trips the circuit breaker.

The stage  $I_{0>>>>}$  should be set based on the calculated unbalance current change of one faulty element. You can calculate this using the following formula:

$$3I_0 = \frac{\frac{U_{L-N}}{(2 \cdot \pi \cdot f \cdot C_1)^{-1}} - \frac{U_{L-N}}{(2 \cdot \pi \cdot f \cdot C_2)^{-1}}}{3}$$

C1 = Capacitor unit capacitance ( $\mu\text{F}$ )

C2 = Capacitor unit capacitance, after one element fails ( $\mu\text{F}$ )

However, the setting must be 10 % smaller than the calculated value, since there are some tolerances in the primary equipment as well as in the relay measurement circuit. Then, the time setting of  $I_{0>>>>}$  is not used for tripping purposes. The time setting specifies, how long the relay must wait until it is certain that there is a faulty element in the bank. After this time has elapsed, the stage  $I_{0>>>>}$  makes a new compensation automatically, and the measured unbalance current for this stage is now zero. Note, the automatic compensation does not affect the measured unbalance current of stage  $I_{0>>>}$ .



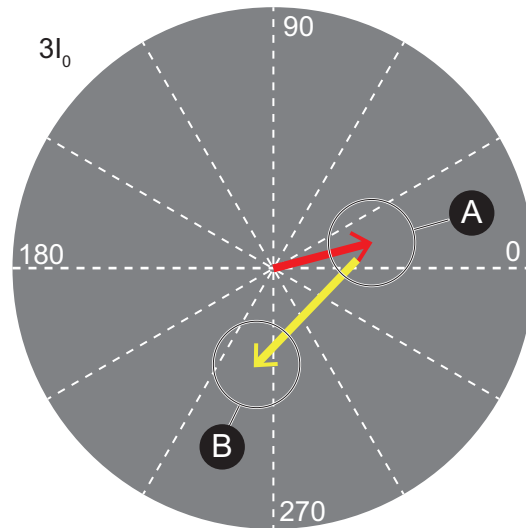

- A. The natural unbalance is compensated for.
- B. When the  $I_0$  current increases above the set start value (normally 90 % of a single capacitor unit) according to the angle ratio between  $I_0$  and  $I_{L1}$ , it is decided in which branch and phase the fault occurred. The fault is memorised and compensation is completed automatically. After the set amount of faults, the stage trips.

Figure 6.51: Natural unbalance compensation and a single capacitor fault

If there is an element failure in the bank, the algorithm checks the phase angle of the unbalance current related to the phase angle of the phase current  $I_{L1}$ . Based on this angle, the algorithm can increase the corresponding faulty elements counter (there are six counters).

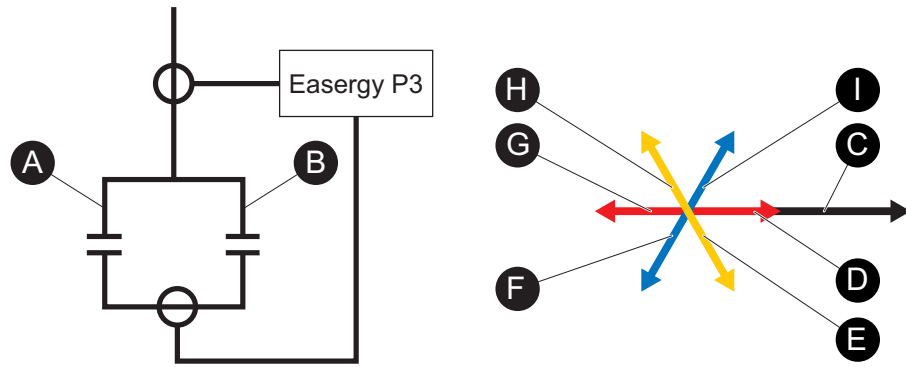

- A. Branch 1
- B. Branch 2
- C. IL1 as reference
- D. Phase 1 fault in branch 1
- E. Phase 3 fault in branch 2
- F. Phase 2 fault in branch 1
- G. Phase 1 fault in branch 2
- H. Phase 3 fault in branch 1
- I. Phase 2 fault in branch 2

Figure 6.52: How a failure in different branches of the bank affects the  $I_0$  measurement

You can set for the stage  $I_0$  the allowed number of faulty elements. For example, if set to three elements, the fourth fault element will issue the trip signal.

The fault location is used with internal fused capacitor and filter banks. There is no need to use it with fuseless or external fused capacitor and filter banks, nor with the reactor banks.

### Application example

An application example is presented below. Each capacitor unit has 12 elements in parallel and four elements in series.

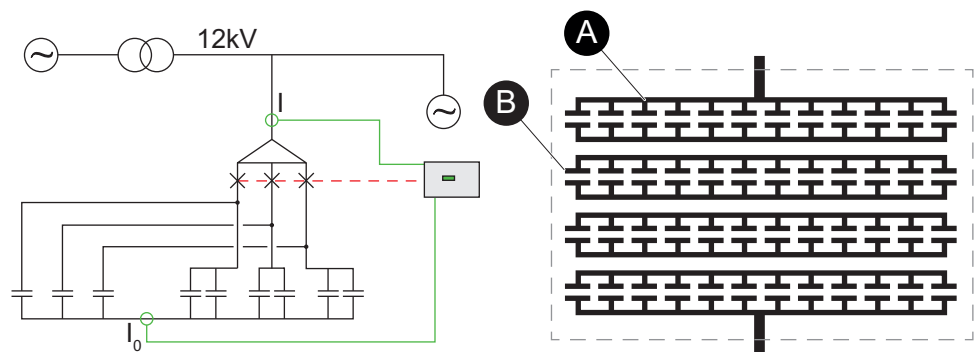

- A. 12 in parallel
- B. Four in series

Figure 6.53: 131.43  $\mu\text{F}$  Y-Y connected capacitor bank with internal fuses

### Taking unbalance protection into use

1. Enable the capacitor bank protection:
  - in Easergy Pro, in the **Protection > I<sub>0</sub>>>>> Unbalance** setting view, select **Location** for **Compensation mode**.

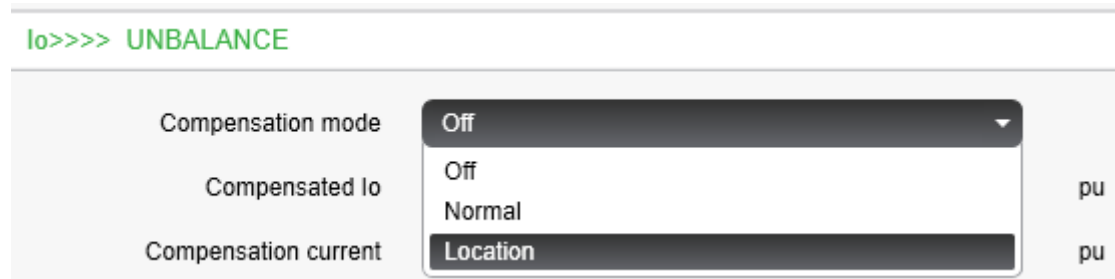

Figure 6.54: Enabling unbalance protection

- via the relay's front panel: go to the **I<sub>0</sub>>>>>** menu, scroll right to **1 SET 50N/51N**, and select **Location** for **CMode**.
2. Save the natural unbalance:
    - in Easergy Pro, in the **Protection > I<sub>0</sub>>>>> Unbalance** setting view, select **Get** for **Save unbalance current**.



Figure 6.55: Saving the unbalance current

- via the relay's front panel: go to the **I<sub>0</sub>>>>>** menu, scroll right to **SET2 50N/51N**, and select **Get** for **SaveBal**.

**NOTE:** **CMode** has to be selected as **Location** before proceeding to this step.

3. Set the start value for both branches.  
Total capacitance of the bank is 131.43  $\mu\text{F}$ . In each phase, there are three capacitor units (1+2), so the capacitance of one unit is 43.81  $\mu\text{F}$ . Failure of one element inside the capacitor unit makes the total capacitance decrease to 41.92  $\mu\text{F}$  (Ohm's law). This value is important when calculating the start value.

$$3I_0 = \frac{\frac{U_{L-N}}{(2 \cdot \pi \cdot f \cdot C_1)^{-1}} - \frac{U_{L-N}}{(2 \cdot \pi \cdot f \cdot C_2)^{-1}}}{3}$$

$$3I_0 = \frac{\frac{6928}{(2 \cdot \pi \cdot 50 \cdot 43.81 \cdot 10^{-6})^{-1}} - \frac{6928}{(2 \cdot \pi \cdot 50 \cdot 43.81 \cdot 10^{-6})^{-1}}}{3}$$

$$3I_0 = 1.37A$$

Failure of one element inside the bank on the left branch causes approximately 1.37 ampere unbalance current at the star point. On the right branch, there are two capacitor units in parallel, and therefore, a failure of one element causes only 0.69 ampere unbalance. A different start value for each branch is necessary. Set the start value to 80% of the calculated value.

4. Test the operation of the unbalance protection.

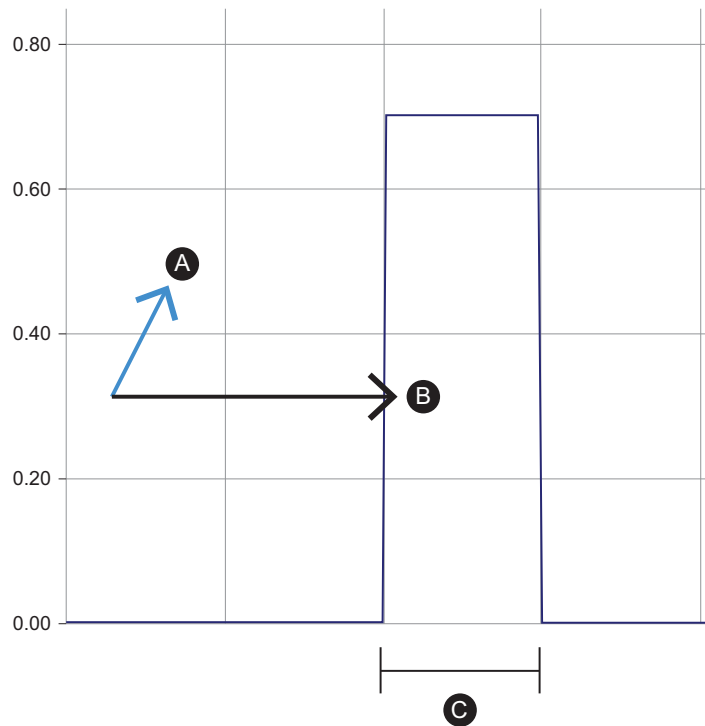

- A. Phase 2 fault in branch 2
- B. IL1 as reference
- C. Set operation delay

Figure 6.56: Testing

Conduct testing by injecting current to channels IL1 and I01 of the relay. In the example above, 0.69 A primary current is injected to the I01 channel. I01 is leading the phase current IL1 by 60 degrees. This means the fault has to be on the right branch and

in phase 2. Compensation happens automatically after the set operate time until the allowed total amount of failed units is exceeded (Max. allowed faults). In this application, the fourth failed element would cause the stage to trip.

**NOTE:** If branch 1 faults occur in branch 2, change the polarity of the  $I_0$  input. Clear the location counters when the commissioning of the relay has been completed.

**I0>>>> UNBALANCE LOCATION**

Max allowed faults  3

Total # of faults 0

Clear location counters

L1 branch 1 counter 0

L1 branch 2 counter 0

L2 branch 1 counter 0

L2 branch 2 counter 0

L3 branch 1 counter 0

L3 branch 2 counter 0

Figure 6.57: Clearing location counters

## Characteristics

Table 6.25: Capacitor bank unbalance  $I_0>>>>$  and  $I_0>>>>>$  (51C)

Start value	0.01-20.0 pu (step 0.01)
Operate time	0.04-300 s (step 0.01)
Start time	Typically 30 ms
Reset time	<95 ms
Reset ratio	0.95
Inaccuracy:	
- Starting	±2% of the set value or ±0.3% of the rated value
- Operate time	±1% or ±25 ms

# 6.18 Locked rotor (ANSI 51LR)

## Description

The locked rotor protection stage  $I_{lr}>$  measures the fundamental frequency component of the phase currents and calculates the average of the measured three phase currents (= phase current  $I_L$ ). The locked rotor stage protects the motor when too heavy load or a mechanical failure of the motor causes rotor jam during the motor running condition.

The stage's start setting is relative to the motor's nominal starting current. The nominal starting current can be configured in the Motor start-up supervision stage (ANSI 48).

The locked rotor stage can be configured for definite time or dependent time operation characteristic. Equation 6.9 defines the dependent operate time.

Equation 6.9:

$$T = \left( \frac{I_{START}}{I_{MEAS}} \right)^2 k$$

$T =$             Dependent operate time  
 $I_{START}$  = Nominal motor starting current  
 $I_{MEAS}$  = Average of measured phase currents during fault  
 $k =$             Dependent time coefficient

When the calculated average phase current  $I_L$  exceeds the defined start setting, the locked rotor protection stage starts operation delay calculation. The stage releases when the average phase current  $I_L$  drops below the start setting. The stage operation is automatically blocked when the motor status is “starting”. For details of the criteria for motor status, see Motor status view.

## Block diagram

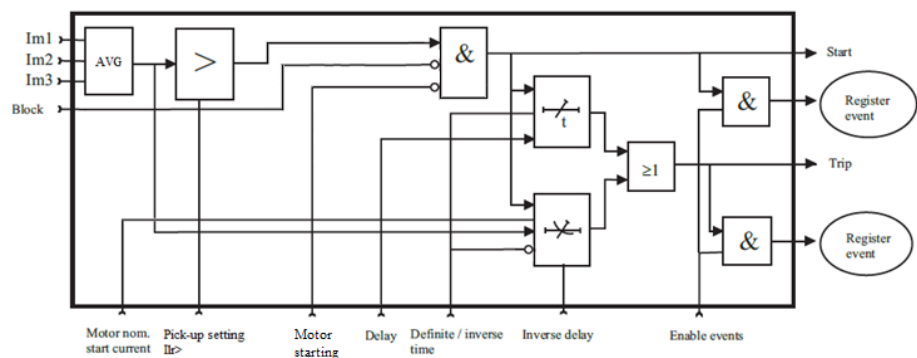

Figure 6.58: Block diagram of the locked rotor protection stage  $I_{lr}>$

## Setting groups

This stage has one setting group.

## Characteristics

**Table 6.26: Locked rotor (51LR) in motor mode**

Start value	10 – 100 % $I_{MOTSt}$ (step 0.1%)
Delay type	DT, INV
Definite time characteristic (DT): - Operate time	1.0 – 300.0 s (step 0.1)**)
Dependent time characteristic (INV): - Dependent time coefficient, k	1.0 – 200.0 s (step 0.1)
Start time	Typically 60 ms
Reset time	<95 ms
Reset ratio	<0.95
Inaccuracy: - Starting - Operate time at definite time function - Operate time at IDMT function	$\pm 3\%$ of the set value or 5 mA secondary $\pm 1\%$ or at $\pm 30$ ms $\pm 5\%$ or at least $\pm 30$ ms

\*\*\*) This is the instantaneous time i.e. the minimum total operational time including the fault detection time and operation time of the trip contacts.

## 6.19 Overvoltage (ANSI 59)

### Description

Overvoltage protection is used to detect too high system voltages or to check that there is sufficient voltage to authorize a source transfer.

The overvoltage function measures the fundamental frequency component of the line-to-line voltages regardless of the voltage measurement mode (Chapter 10.6 Voltage measurement modes). By using line-to-line voltages any line-to-neutral over-voltages during earth faults have no effect. (The earth fault protection functions take care of earth faults.) Whenever any of these three line-to-line voltages exceeds the start setting of a particular stage, this stage starts and a start signal is issued. If the fault situation remains on longer than the operate time delay setting, a trip signal is issued.

In solidly earthed, four-wire networks with loads between phase and neutral voltages, overvoltage protection may be needed for line-to-neutral voltages, too. In such applications, the programmable stages can be used. Chapter 6.31 Programmable stages (ANSI 99).

### Three independent stages

There are three separately adjustable stages:  $U>$ ,  $U>>$  and  $U>>>$ . All the stages can be configured for the definite time (DT) operation characteristic.

### Configurable release delay

The  $U>$  stage has a settable reset delay that enables detecting intermittent faults. This means that the time counter of the protection function does not reset immediately after the fault is cleared, but resets after the release delay has elapsed. If the fault appears again before the release delay time has elapsed, the delay counter continues from the previous value. This means that the function eventually trips if faults are occurring often enough.

### Configurable hysteresis

The dead band is 3 % by default. This means that an overvoltage fault is regarded as a fault until the voltage drops below 97 % of the start setting. In a sensitive alarm application, a smaller hysteresis is needed. For example, if the start setting is about only 2 % above the normal voltage level, the hysteresis must be less than 2 %. Otherwise, the stage does not release after fault.



**Block diagram**

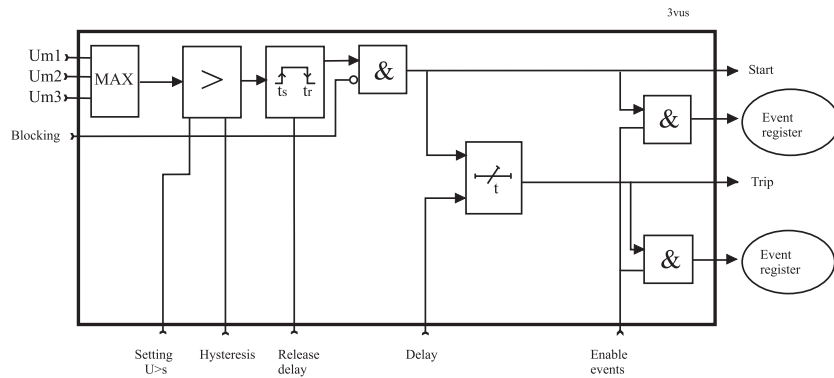

Figure 6.59: Block diagram of the three-phase overvoltage stages  $U>$ ,  $U>>$  and  $U>>>$

**Setting groups**

There are four setting groups available for each stage.

**Characteristics**

Table 6.27: Overvoltage stage  $U>$  (59)

Input signal	$U_{L1} - U_{L3}$
Start value	50 – 150 % $U_N$ (step 1%)
Definite time characteristic: - operate time	0.08** – 300.00 s (step 0.02)
Hysteresis	0.99 – 0.800 (0.1 – 20.0 %, step 0.1 %)
Start time	Typically 60 ms
Release delay	0.06 – 300.00 s (step 0.02)
Reset time	<95 ms
Overshoot time	< 50 ms
Inaccuracy: - Starting - operate time	$\pm 3\%$ of the set value $\pm 1\%$ or $\pm 30$ ms

**Table 6.28: Overvoltage stage U>> (59)**

Input signal	$U_{L1} - U_{L3}$
Start value	50 – 150 % $U_N$ (step 1%) The measurement range is up to 160 V. This limit is the maximum usable setting when rated VT secondary is more than 100 V.
Definite time characteristic: - Operate time	0.06** – 300.00 s (step 0.02)
Hysteresis	0.99 – 0.800 (0.1 – 20.0 %, step 0.1 %)
Start time	Typically 60 ms
Reset time	<95 ms
Overshoot time	< 50 ms
Inaccuracy: - Starting - Operate time	$\pm 3\%$ of the set value $\pm 1\%$ or $\pm 30$ ms

**Table 6.29: Overvoltage stage U>>> (59)**

Input signal	$U_{L1} - U_{L3}$
Start value	50 – 160 % $U_N$ (step 1%) The measurement range is up to 160 V. This limit is the maximum usable setting when rated VT secondary is more than 100 V.
Definite time characteristic: - Operate time	0.04** – 300.00 s (step 0.01)
Hysteresis	0.99 – 0.800 (0.1 – 20.0 %, step 0.1 %)
Start time	Typically 30 ms
Reset time	<95 ms
Overshoot time	< 50 ms
Inaccuracy: - Starting - Operate time	$\pm 3\%$ of the set value $\pm 1\%$ or $\pm 25$ ms

\*\*\*) This is the instantaneous time i.e. the minimum total operational time including the fault detection time and operate time of the trip contacts.

## 6.20 Neutral voltage displacement (ANSI 59N)

### Description

The neutral voltage displacement protection is used as unselective backup for earth faults and also for selective earth fault protections for motors having a unit transformer between the motor and the busbar.

This function is sensitive to the fundamental frequency component of the neutral voltage displacement voltage. The attenuation of the third harmonic is more than 60 dB. This is essential because third harmonics exist between the neutral point and earth also when there is no earth fault.

Whenever the measured value exceeds the start setting of a particular stage, this stage starts and a start signal is issued. If the fault situation remains on longer than the operate time delay setting, a trip signal is issued.

### Measuring the neutral displacement voltage

The neutral displacement voltage is either measured with three voltage transformers (for example broken delta connection), one voltage transformer between the motor's neutral point and earth or calculated from the measured phase-to-neutral voltages according to the selected voltage measurement mode (see Chapter 10.6 Voltage measurement modes):

- When the voltage measurement mode is 3LN: the neutral displacement voltage is calculated from the line-to-line voltages and therefore a separate neutral displacement voltage transformer is not needed. The setting values are relative to the configured voltage transformer (VT) voltage/  $\sqrt{3}$ .
- When the voltage measurement mode contains "+U<sub>0</sub>": The neutral displacement voltage is measured with voltage transformer(s) for example using a broken delta connection. The setting values are relative to the VT<sub>0</sub> secondary voltage defined in configuration.
- Connect the U<sub>0</sub> signal according to the connection diagram to achieve correct polarization.

### Two independent stages

There are two separately adjustable stages: U<sub>0</sub>> and U<sub>0</sub>>>. Both stages can be configured for the definite time (DT) operation characteristic.

The neutral voltage displacement function comprises two separately adjustable neutral voltage displacement stages (stage U<sub>0</sub>> and U<sub>0</sub>>>).

**Block diagram**

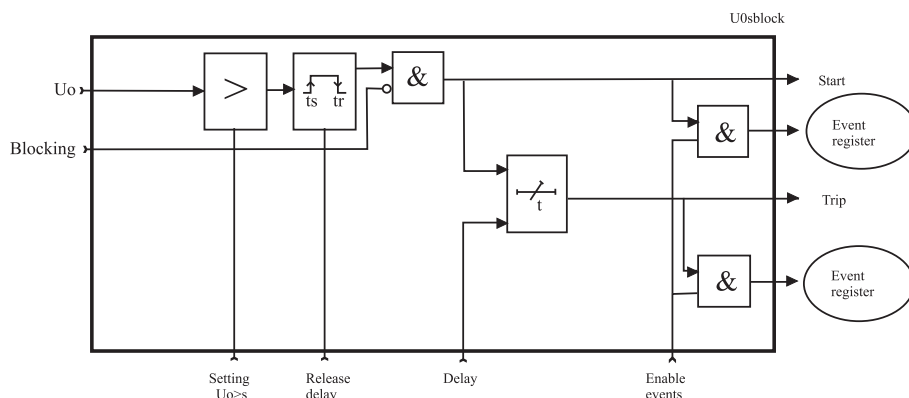

Figure 6.60: Block diagram of the neutral voltage displacement stages  $U_0>$ ,  $U_0>>$

**Setting groups**

There are four setting groups available for both stages.

**Characteristics**

**Table 6.30: Neutral voltage displacement stage  $U_0>$  (59N)**

Input signal	$U_0$ $U_{0Calc} (= U_{L1} + U_{L2} + U_{L3})$
Start value	1 – 60 % $U_{0N}$ (step 1%)
Definite time function: - Operate time	0.3 – 300.0 s (step 0.1 s)
Start time	Typically 200 ms
Reset time	< 450 ms
Reset ratio	<0.97
Inaccuracy: - Starting - Starting $U_{0Calc}$ (3LN mode) - Operate time	$\pm 2\%$ of the set value or $\pm 0.3\%$ of the rated value $\pm 1$ V $\pm 1\%$ or $\pm 150$ ms

**Table 6.31: Neutral voltage displacement stage  $U_0>>$  (59N)**

Input signal	$U_0$ $U_{0Calc} (= U_{L1} + U_{L2} + U_{L3})$
Start value	1 – 60 % $U_{0N}$ (step 1%)
Definite time function: - Operate time	0.08 – 300.0 s (step 0.02 s)
Start time	Typically 60 ms
Reset time	<95 ms
Reset ratio	<0.97
Inaccuracy: - Starting - Starting $U_{0Calc}$ (3LN mode) - Operate time	$\pm 2\%$ of the set value or $\pm 0.3\%$ of the rated value $\pm 1$ V $\pm 1\%$ or $\pm 30$ ms

## 6.21 Motor restart inhibition (ANSI 66)

### Description

The simplest way to start an asynchronous motor is just to switch the stator windings to the supply voltages. However, every such start heats up the motor considerably because the initial currents are significantly above the rated current.

If the motor manufacturer has defined the maximum number of starts within an hour or the minimum time between two consecutive starts, this stage is easy to apply to prevent too frequent starts.

When the current has been less than 10 % of the motor nominal current and then exceeds the value Motor start detection current of  $I_{ST}$  (Motor start-up supervision stage, ANSI 48), the situation is recognized as a motor start. After the recognition of the motor start, if the current drops to less than 10 % of the motor nominal current, the stage considers the motor to be stopped.

The motor restart inhibition stage provides an N> alarm signal when the second last start has been done and remains active until the maximum amount of motor starts have been reached or one hour of time has passed.

The N> motor start inhibit signal activates after starting the motor and remains active a period of time that is defined for parameter Min time between motor starts. After the given time has passed, the inhibit signal returns to inactive state.

When the stage's start counter reaches the value defined for Max. motor starts/hour, the N> motor start inhibit signal activates and remains active until one hour has passed.

Set the parameter **Def. elap time from motor start** to 120 min if the ANSI 66 stage is required to give permission to start the motor immediately after the relay is powered. If this setting is 0 min, the motor is not started until the **Min time between motor starts** delay has elapsed.

The motor restart inhibition stage's correlation to the output contacts is defined in the output matrix menu. See Chapter 5.4.1 Output matrix.

Figure 6.61 shows an application for preventing too frequent starting using the N> stage. Closed coil wire has been connected through the normal close (NC) contact of the signal relay A1, and A1 is controlled with the N> start inhibit signal. Whenever the N> motor start inhibit signal becomes active, it prevents circuit breaker closing.

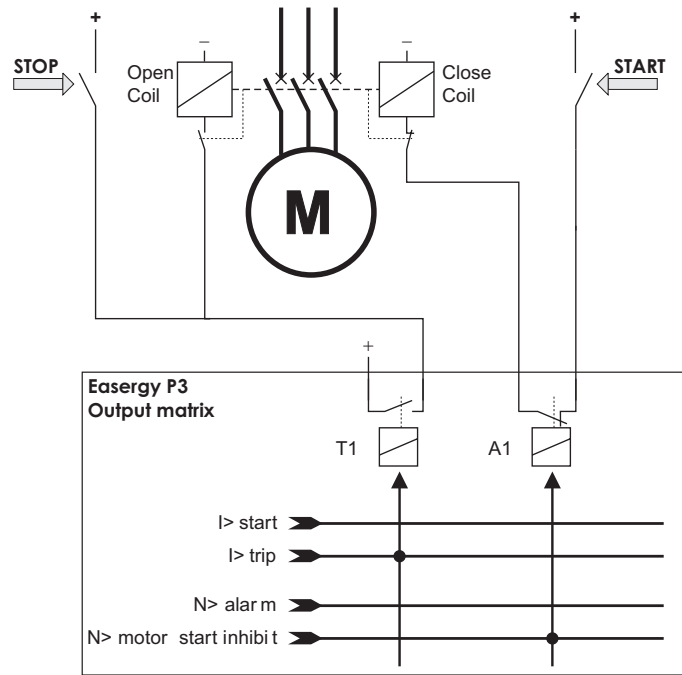

Figure 6.61: Application for preventing too frequent starting using the N> stage

### Setting groups

This stage has one setting group.

### Characteristics

Table 6.32: Motor restart inhibition N> (66)

Input signal	$I_{L1} - I_{L3}$
Settings:	
- Max. motor starts	1 – 20
- Min. time between motor starts *)	0.0–100 min. (step 0.1 min)
- Def. elap. (default elapsed) time from motor start	0 or 120 min

\*) If *Min. time between motors starts* is set to zero, this function is disabled, that is, the minimum time between successive motor starts is not considered.

## 6.22 Directional phase overcurrent (ANSI 67)

### Description

Directional overcurrent protection can be used for directional short circuit protection. Typical applications are:

- Short-circuit protection of two parallel cables or overhead lines in a radial network.
- Short-circuit protection of a looped network with single feeding point.
- Short-circuit protection of a two-way feeder, which usually supplies loads but is used in special cases as an incoming feeder.
- Directional overcurrent protection in low impedance earthed networks. In this case, the relay has to be connected to line-to-neutral voltages instead of line-to-line voltages. In other words, the voltage measurement mode has to be "3LN" (See chapter Chapter 10.6 Voltage measurement modes).

The stages are sensitive to the amplitude of the highest fundamental frequency current of the three measured phase currents.

In line-to-line and in three-phase faults, the fault angle is determined by using angles between positive sequence of currents and voltages. In line-to-neutral faults, the fault angle is determined by using fault-phase current and the healthy line to line voltage. For details of power direction, see Chapter 4.9 Power and current direction.

A typical characteristic is shown in Figure 6.62. The base angle setting is  $-30^\circ$ . The stage starts if the tip of the three phase current phasor gets into the grey area.

**NOTE:** If the maximum possible earth fault current is greater than the used most sensitive directional over current setting, connect the relay to the line-to-neutral voltages instead of line-to-line voltages to get the right direction for earth faults, too. For networks having the maximum possible earth fault current less than the over current setting, use 67N, the directional earth fault stages.

### Voltage memory

An adjustable 0.2–3.2 second cyclic buffer storing the phase-to-earth voltages is used as the voltage memory. The stored phase angle information is used as direction reference if all the line-to-line voltages drop below 1% during a fault. To adjust the voltage memory, set the **Angele memory duration** parameter in the **Scalings** setting view in Easergy Pro.

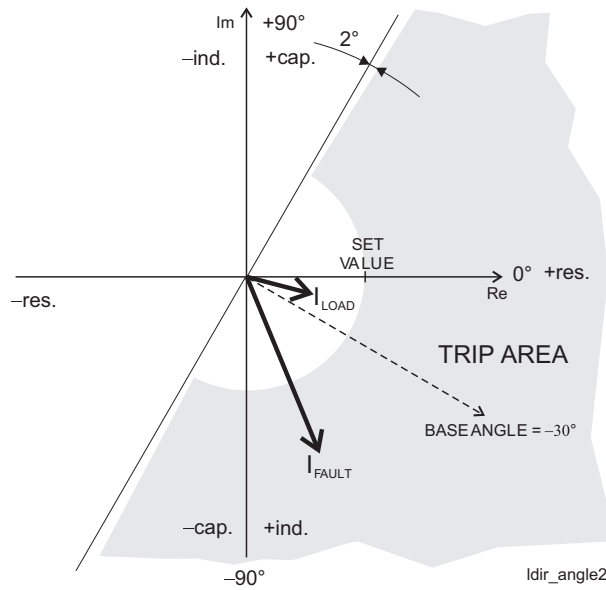

Figure 6.62: Example of the directional overcurrent function's protection area

Three modes are available: dirctional, non-direct, and directional+back-up (Figure 6.63). In the non-directional mode, the stage is acting just like an ordinary overcurrent 50/51 stage.

Directional+back-up mode works the same way as the directional mode, but it has undirectional backup protection in case a close-up fault forces all voltages to about zero. After the angle memory hold time, the direction would be lost. Basically the directional+backup mode is required when operate time is set longer than voltage memory setting and no other undirectional back-up protection is in use.

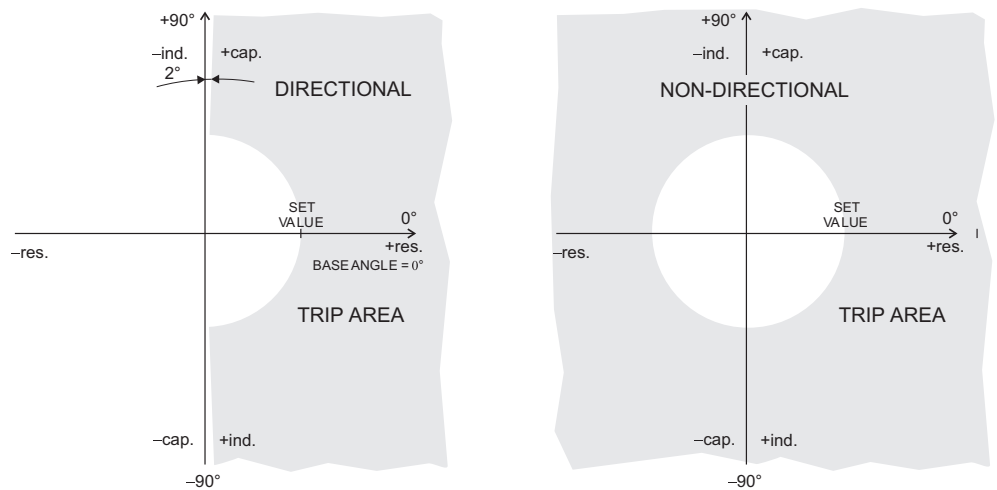

Figure 6.63: Difference between directional mode and non-directional mode. The grey area is the trip region.

An example of bi-directional operation characteristic is shown in Figure 6.64. The right side stage in this example is the stage  $I_{\phi} >$  and the left side is  $I_{\phi} >>$ . The base angle setting of the  $I_{\phi} >$  is  $0^\circ$  and the base angle of  $I_{\phi} >>$  is set to  $-180^\circ$ .



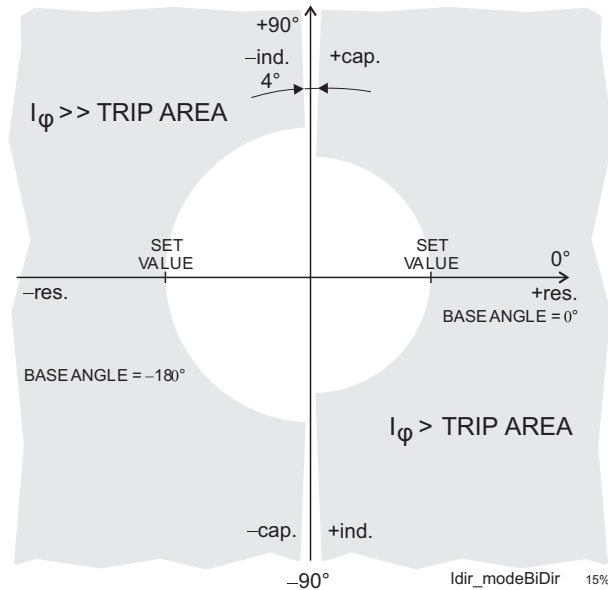

Figure 6.64: Bi-directional application with two stages  $I_{\phi}>$  and  $I_{\phi}>>$ .

When any of the three phase currents exceeds the setting value and, in directional mode, the phase angle including the base angle is within the active  $\pm 88^\circ$  wide sector, the stage starts and issues a start signal. If this fault situation remains on longer than the delay setting, a trip signal is issued.

#### Four independent stages

There are four separately adjustable stages available:  $I_{\phi}>$ ,  $I_{\phi}>>$ ,  $I_{\phi}>>>$  and  $I_{\phi}>>>>$ .

#### Dependent operate time

Stages  $I_{\phi}>$  and  $I_{\phi}>>$  can be configured for definite time or dependent time characteristic. See Chapter 6.3 Dependent operate time for details of the available dependent delays. Stages  $I_{\phi}>>>$  and  $I_{\phi}>>>>$  have definite time (DT) operation delay. The relay shows a scaleable graph of the configured delay on the local panel display.

#### Dependent time limitation

The maximum measured secondary current is  $50 \times I_N$ . This limits the scope of dependent curves with high start settings. See Chapter 6.3 Dependent operate time for more information.

#### Setting groups

There are four setting groups available for each stage.

## Characteristics

**Table 6.33: Directional phase overcurrent  $I_{\phi}>$ ,  $I_{\phi}>>$  (67)**

Input signal	$I_{L1} - I_{L3}$ $U_{L1} - U_{L3}$
Start value	0.10–4.00 $\times I_{MOT}$ (step 0.01)
Mode	Directional/Directional+BackUp
Minimum voltage for the direction solving	2 $V_{SECONDARY}$
Base angle setting range	-180° – +179°
Operate angle	$\pm 88^\circ$
Definite time function: - Operate time	DT** 0.04–300.00 s (step 0.01)
IDMT function: - Delay curve family - Curve type - Inv. time coefficient k	(DT), IEC, IEEE, RI Prg EI, VI, NI, LTI, MI...depends on the family* 0.025–20.0, except 0.50–20.0 for RXIDG, IEEE and IEEE2
Start time	Typically 30 ms
Reset time	<95 ms
Overshoot time	< 50 ms
Reset ratio	<0.95
Reset ratio (angle)	2°
Transient overreach, any $\tau$	< 10 %
Angle memory duration	0.2–3.2 s
Inaccuracy: - Starting (rated value $I_N = 1-5A$ ) - Angle - Operate time at definite time function - Operate time at IDMT function	$\pm 3\%$ of the set value or $\pm 0.5\%$ of the rated value $\pm 2^\circ$ $U > 5 V$ $\pm 30^\circ$ $U = 0.1-5.0 V$ $\pm 1\%$ or $\pm 25$ ms $\pm 5\%$ or at least $\pm 30$ ms**

**Table 6.34: Directional phase overcurrent  $I_{\phi}>>>$ ,  $I_{\phi}>>>>$  (67)**

Input signal	$I_{L1} - I_{L3}$ $U_{L1} - U_{L3}$
Start value	0.10 – 20.00 x $I_{MODE}$ (step 0.01)
Mode	Directional/Directional+BackUp
Minimum voltage for the direction solving	2 $V_{SECONDARY}$
Base angle setting range	-180° – +179°
Operate angle	±88°
Definite time function: - Operate time	DT** 0.04 – 300.00 s (step 0.01)
Start time	Typically 30 ms
Reset time	<95 ms
Overshoot time	< 50 ms
Reset ratio	<0.95
Reset ratio (angle)	2°
Transient overreach, any $\tau$	< 10 %
Angle memory duration	0.2 – 3.2 s
Inaccuracy: - Starting (rated value $I_N = 1 - 5A$ ) - Angle - Operate time at definite time function	±3% of the set value or ±0.5% of the rated value ±2° $U > 5 V$ ±30° $U = 0.1 - 5.0 V$ ±1% or ±25 ms

\*) EI = Extremely Inverse, NI = Normal Inverse, VI = Very Inverse, LTI = Long Time Inverse, MI = Moderately Inverse

\*\*) This is the instantaneous time i.e. the minimum total operational time including the fault detection time and operate time of the trip contacts.

## 6.23 Directional earth fault overcurrent (ANSI 67N)

### Description

The directional earth fault overcurrent is used in networks or motors where a selective and sensitive earth fault protection is needed and in applications with varying network structure and length.

The earth fault protection is adapted for various network earth systems.

The function is sensitive to the fundamental frequency component of the earth fault overcurrent and neutral voltage displacement voltage and the phase angle between them. The attenuation of the third harmonic is more than 60 dB. Whenever the size of  $I_0$  and  $U_0$  and the phase angle between  $I_0$  and  $U_0$  fulfils the start criteria, the stage starts and a start signal is issued. If the fault situation remains on longer than the operate time delay setting, a trip signal is issued.

### Polarization

The neutral displacement voltage, used for polarization, is measured by energizing input  $U_0$ , that is, the angle reference for  $I_0$ . Connect the  $U_0$  signal according to the connection diagram. Alternatively, the  $U_0$  can be calculated from the line-to-line voltages internally depending on the selected voltage measurement mode (see Chapter 10.6 Voltage measurement modes):

- $3LN/LL_Y$ ,  $3LN/LN_Y$  and  $3LN/U_0$ : the zero sequence voltage is calculated from the line-to-line voltages and therefore any separate zero sequence voltage transformers are not needed. The setting values are relative to the configured voltage transformer (VT) voltage/  $\sqrt{3}$ .
- $3LN+U_0$ ,  $2LL+U_0$ ,  $2LL+U_0+LL_Y$ ,  $2LL+U_0+LN_Y$ ,  $LL+U_0+LL_Y+LL_Z$ , and  $LN+U_0+LN_Y+LN_Z$ : the neutral voltage displacement voltage is measured with voltage transformer(s) for example using a broken delta connection. The setting values are relative to the  $VT_0$  secondary voltage defined in the configuration.

### Modes for different network types

The available modes are:

- ResCap
 

This mode consists of two sub modes, Res and Cap. A digital signal can be used to dynamically switch between these two submodes. When the digital input is active (DI = 1), Cap mode is in use and when the digital input is inactive (DI = 0), Res mode is in use. This feature can be used with compensated networks when the Petersen coil is temporarily switched off.

  - Res
 

The stage is sensitive to the resistive component of the selected  $I_0$  signal. This mode is used with compensated **networks** (resonant earthing) and **networks earthed with a high resistance**. Compensation is usually done with a Petersen coil between the neutral point of the main transformer and earth. In this context, high resistance means that the fault current is limited to be less than the rated phase current. The trip area is a half plane as drawn in Figure 6.66. The base angle is usually set to zero degrees.
  - Cap
 

The stage is sensitive to the capacitive component of the selected  $I_0$  signal. This mode is used with **unearthed networks**. The trip area is a half plane as drawn in Figure 6.66. The base angle is usually set to zero degrees.
- Sector
 

This mode is used with **networks earthed with a small resistance**. In this context, "small" means that a fault current may be more than the rated phase currents. The trip area has a shape of a sector as drawn in Figure 6.67. The base angle is usually set to zero degrees or slightly on the lagging inductive side (negative angle).
- Undir
 

This mode makes the stage equal to the unidirectional stage  $I_0 >$ . The phase angle and  $U_0$  amplitude setting are discarded. Only the amplitude of the selected  $I_0$  input is supervised.

### Input signal selection

Each stage can be connected to supervise any of the following inputs and signals:

- Input  $I_{01}$  for all networks other than solidly earthed.
- Input  $I_{02}$  for all networks other than solidly earthed.
- Calculated signal  $I_{0Calc}$  for solidly and low-impedance earthed networks.  $I_{0Calc} = I_{L1} + I_{L2} + I_{L3} = 3I_0$ .

### Intermittent earth fault detection

Short earth faults make the protection start but does not cause a trip. A short fault means one cycle or more. For shorter than 1 ms transient type of intermittent earth faults in compensated networks, there is a dedicated stage  $I_{0INT} > 67N_I$ . When starting happens often enough, such intermittent faults can be cleared using the intermittent time setting.

When a new start happens within the set intermittent time, the operation delay counter is not cleared between adjacent faults and finally the stage trips.

### Two independent stages

There are two separately adjustable stages:  $I_{0\phi} >$  and  $I_{0\phi} >>$ . Both stages can be configured for definite time delay (DT) or dependent time delay operate time.

### Dependent operate time

Accomplished dependent delays are available for all stages  $I_{0\phi} >$  and  $I_{0\phi} >>$ . The relay shows a scaleable graph of the configured delay on the local panel display.

### Dependent time limitation

The maximum measured secondary earth fault overcurrent is  $10 \times I_{0N}$  and the maximum measured phase current is  $50 \times I_N$ . This limits the scope of dependent curves with high start settings.

### Block diagram

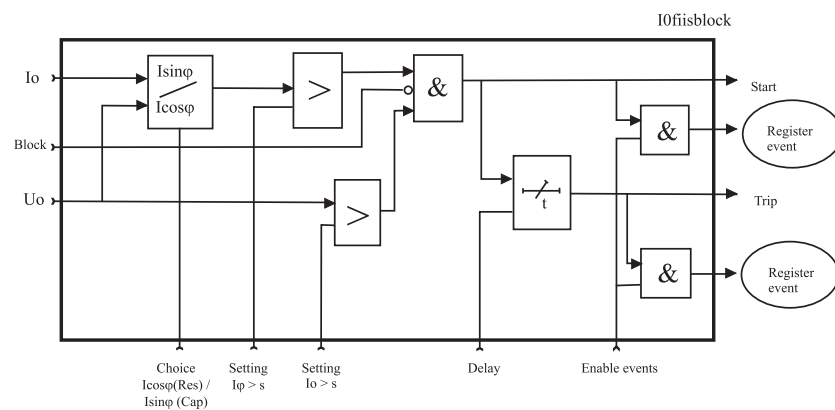

Figure 6.65: Block diagram of the directional earth fault overcurrent stages  $I_{0\phi} >$ ,  $I_{0\phi} >>$

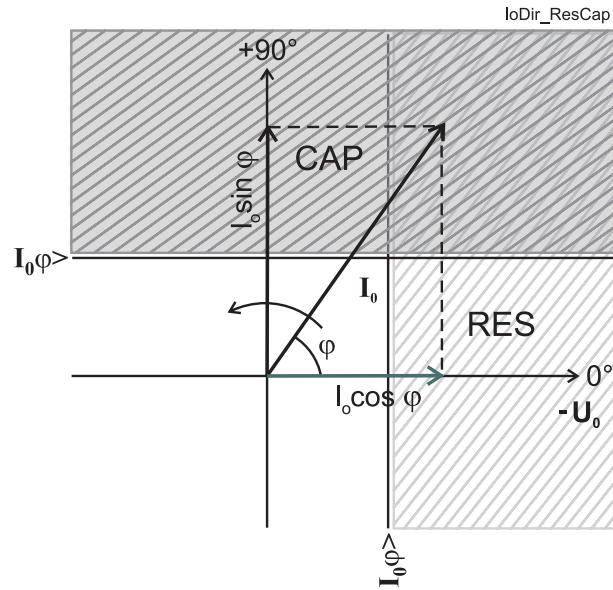

Figure 6.66: Operation characteristic of the directional earth fault protection in Res or Cap mode. Res mode can be used with compensated networks and Cap mode is used with unearthed networks.

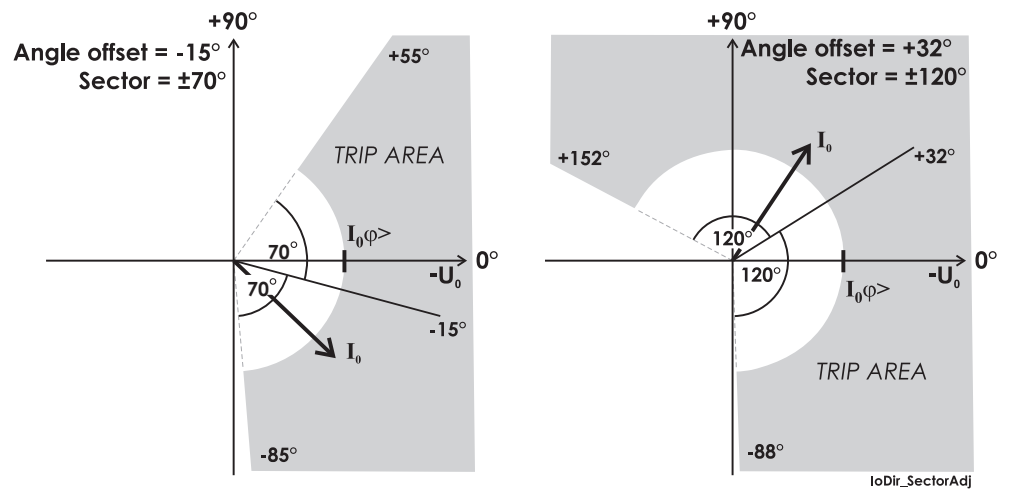

Figure 6.67: Two examples of operation characteristics of the directional earth fault stages in sector mode. The drawn  $I_0$  phasor in both figures is inside the trip area. The angle offset and half sector size are user's parameters.

### Setting groups

There are four setting groups available for each stage.

## Characteristics

**Table 6.35: Directional earth fault overcurrent  $I_{0\phi}>$ ,  $I_{0\phi}>>$  (67N)**

Input signal	$I_0$ , $U_0$ $I_{0Calc}$ ( $= I_{L1} + I_{L2} + I_{L3}$ )
Start value	0.005–20.00 x $I_{0N}$ (up to 8.00 for inputs other than $I_{0Calc}$ )
Start voltage	1–50 % $U_{0N}$ (step 1%)
Mode	Non-directional/Sector/ResCap
Base angle setting range	-180°–179°
Operate angle	±88°
Definite time function: - Operate time	0.10** – 300.00 s (step 0.02 s)
IDMT function: - Delay curve family - Curve type - Inv. time coefficient k	(DT), IEC, IEEE, RI Prg EI, VI, NI, LTI, MI..., depends on the family* 0.025–20.0, except 0.50–20.0 for RI, IEEE and IEEE2
Start time	Typically 60 ms
Reset time	<95 ms
Reset ratio	<0.95
Reset ratio (angle)	2°
Inaccuracy:	
- Starting $U_0$ & $I_0$ (rated value $I_n = 1–5A$ )	±3% of the set value or ±0.3% of the rated value
- Starting $U_0$ & $I_0$ (Peak Mode when, rated value $I_{0n} = 1–10A$ )	±5% of the set value or ±2% of the rated value (Sine wave <65 Hz)
- Starting $U_0$ & $I_0$ ( $I_{0Calc}$ )	±3% of the set value or ±0.5% of the rated value
- Angle	±2° when $U > 1V$ and $I_0 > 5\%$ of $I_{0N}$ or $> 50$ mA else ±20°
- Operate time at definite time function	±1% or ±30 ms
- Operate time at IDMT function	±5% or at least ±30 ms**



**Table 6.36: Directional earth fault overcurrent  $I_{0\phi}>>>$  (67N)**

Input signal	$I_0, U_0$ $I_{0Calc} (= I_{L1} + I_{L2} + I_{L3})$
Start value	0.005 – 20.00 x $I_{0N}$ (up to 8.00 for inputs other than $I_{0Calc}$ )
Start voltage	1 – 50 % $U_{0N}$ (step 1%)
Mode	Non-directional/Sector/ResCap
Base angle setting range	-180° – 179°
Operation angle	±88°
Definite time function: - Operate time	0.10** – 300.00 s (step 0.02 s)
IDMT function: - Delay curve family - Curve type - Inv. time coefficient k	(DT), IEC, IEEE, RI Prg EI, VI, NI, LTI, MI..., depends on the family* 0.05 – 20.0, except 0.50 – 20.0 for RI, IEEE and IEEE2
Start time	Typically 60 ms
Reset time	<95 ms
Reset ratio	<0.95
Reset ratio (angle)	2°
Inaccuracy:	
- Starting $U_0$ & $I_0$ (rated value $I_n = 1 – 5A$ )	±3% of the set value or ±0.3% of the rated value
- Starting $U_0$ & $I_0$ (Peak Mode when, rated value $I_{0N} = 1 – 10A$ )	±5% of the set value or ±2% of the rated value (Sine wave <65 Hz)
- Starting $U_0$ & $I_0$ ( $I_{0Calc}$ )	±3% of the set value or ±0.5% of the rated value
- Angle	±2° when $U > 1V$ and $I_0 > 5%$ of $I_{0N}$ or $> 50$ mA else ±20°
- Operate time at definite time function	±1% or ±30 ms
- Operate time at IDMT function	±5% or at least ±30 ms**

\*) EI = Extremely Inverse, NI = Normal Inverse, VI = Very Inverse, LTI = Long Time Inverse, MI = Moderately Inverse

\*\*\*) This is the instantaneous time i.e. the minimum total operational time including the fault detection time and operation time of the trip contacts.

### 6.23.1

## Earth fault faulty phase detection algorithm

The earth fault overcurrent stage (ANSI 50N/51N) and directional earth fault overcurrent stage (ANSI 67N) have an inbuilt detection algorithm to detect a faulty phase. This algorithm is meant to be used in radial-operated distribution networks. The faulty phase detection can be used in solidly-earthed, impedance-earthed or resonant-earthed networks.

## Operation

The faulty phase detection starts from the earth fault stage trip. At the moment of stage start, the phase currents measured prior to start are registered and stored as prior-to-fault currents. At the moment of trip, phase currents are registered again. Finally, faulty phase detection algorithm is performed by comparing prior-to-fault currents to fault currents. The algorithm also uses positive sequence current and negative sequence current to detect faulty phase.

The detection algorithm can be enabled and disabled by selecting or unselecting a checkbox in the protection stage settings. Correct network earthing configuration must be selected in the stage settings, too. In the earth fault overcurrent stage settings, you can select between RES and CAP network earthing configuration. This selection has no effect on the protection itself, only on the faulty phase detection. In the directional earth fault overcurrent stage settings, the detection algorithm uses the same network earthing type as selected for protection. RES is used for solidly-earthed, impedance-earthed and resonant-earthed networks. CAP is only used for isolated networks.

The detected faulty phase is registered in the protection stage fault log (and also in the event list and alarm screen). Faulty phase is also indicated by a line alarm and line fault signals in the output matrix.

Possible detections of faulty phases are L1-N, L2-N, L3-N, L1-L2-N, L1-L3-N, L2-L3-N, L1-L2-L3-N, and REV. If the relay protection coordination is incorrect, REV indication is given in case of a relay sympathetic trip to a reverse fault.

## 6.24 Magnetising inrush detection (ANSI 68F2)

### Description

This stage is mainly used to block other stages. The ratio between the second harmonic component and the fundamental frequency component is measured on all the phase currents. When the ratio in any phase exceeds the setting value, the stage gives a start signal. After a settable delay, the stage gives a trip signal.

The start and trip signals can be used for blocking the other stages. The trip delay is irrelevant if only the start signal is used for blocking. The trip delay of the stages to be blocked must be more than 60 ms to ensure a proper blocking.

### Block diagram

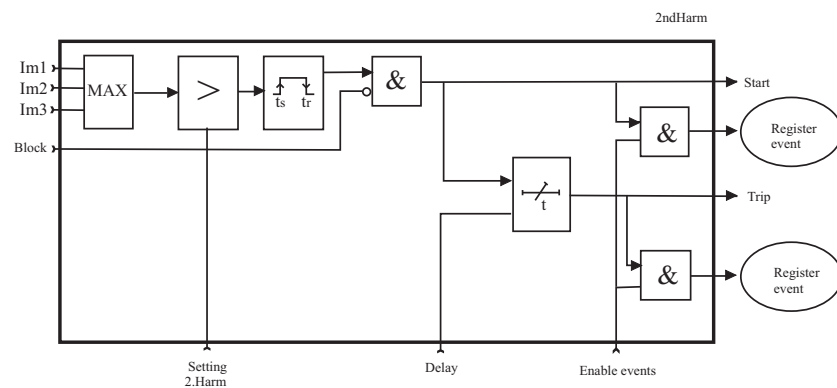

Figure 6.68: Block diagram of the magnetising inrush detection stage

### Characteristics

Table 6.37: Magnetising inrush detection (68F2)

Input signal	$I_{L1} - I_{L3}$
Settings:	
- Start value	10 – 100 % (step 1%)
- Operate time	0.03 – 300.00 s (step 0.01 s)
Inaccuracy:	
- Starting	$\pm 1\%$ - unit

**NOTE:** The amplitude of second harmonic content has to be at least 2% of the nominal of CT. If the nominal current is 5 A, the 100 Hz component needs to exceed 100 mA.

## 6.25 Fifth harmonic detection (ANSI 68H5)

### Description

Overexciting a transformer creates odd harmonics. The fifth harmonic detection stage can be used detect overexcitation. This stage can also be used to block some other stages.

The ratio between the fifth harmonic component and the fundamental frequency component is measured on all the phase currents. When the ratio in any phase exceeds the setting value, the stage activates a start signal. After a settable delay, the stage operates and activates a trip signal.

The trip delay of the stages to be blocked must be more than 60 ms to ensure a proper blocking.

### Characteristics

**Table 6.38: Fifth harmonic detection (68H5)**

Input signal	$I_{L1} - I_{L3}$
Settings:	
- Setting range over excitation	10 – 100 % (step 1%)
- Operate time	0.03 – 300.00 s (step 0.01 s)
Inaccuracy:	
- Starting	±2%- unit

## 6.26 Overfrequency and underfrequency (ANSI 81)

### Description

Frequency protection is used for load sharing, loss of power system detection and as a backup protection for overspeeding.

The frequency function measures the frequency from the two first voltage inputs. At least one of these two inputs must have a voltage connected to be able to measure the frequency. Whenever the frequency crosses the start setting of a particular stage, this stage starts, and a start signal is issued. If the fault remains on longer than the operating delay setting, a trip signal is issued. For situations where no voltage is present, an adapted frequency is used.

### Protection mode for $f >$ and $f >><<$ stages

These two stages can be configured either for overfrequency or for underfrequency.

### Undervoltage self-blocking of underfrequency stages

The underfrequency stages are blocked when the biggest of the three line-to-line voltages is below the low-voltage block limit setting. With this common setting, LVBlk, all stages in underfrequency mode are blocked when the voltage drops below the given limit. The idea is to avoid purposeless alarms when the voltage is off.

### Initial self-blocking of underfrequency stages

When the biggest of the three line-to-line voltages has been below the block limit, the underfrequency stages are blocked until the start setting has been reached.

### Four independent frequency stages

There are four separately adjustable frequency stages:  $f >$ ,  $f >><<$ ,  $f <$ ,  $f <<$ . The two first stages can be configured for either overfrequency or underfrequency usage. So totally four underfrequency stages can be in use simultaneously. Using the programmable stages even more can be implemented (chapter Chapter 6.31 Programmable stages (ANSI 99)). All the stages have definite operate time delay (DT).

### Setting groups

There are four setting groups available for each stage.

## Characteristics

**Table 6.39: Overfrequency and underfrequency  $f > <$ ,  $f > < <$  (81H/81L)**

Input signal	$U_{L1} - U_{L3}$
Frequency measuring area	16.0 – 75.0 Hz
Current and voltage meas. range	45.0 – 65.0 Hz
Frequency stage setting range	40.0 – 70.0 Hz (step 0.01)
Low voltage blocking	10 – 100 % $U_N$
Definite time function: - Operate time	0.10** – 300.0 s (step 0.02 s)
Start time	< 100 ms
Reset time	<120 ms
Reset ratio (LV block)	Instant (no hysteresis)
Inaccuracy: - Starting - Starting (LV block) - operate time	$\pm 20$ mHz 3% of the set value or $\pm 0.5$ V $\pm 1\%$ or $\pm 30$ ms

**NOTE:** If the relay restarts for some reason, there is no trip even if the frequency is below the set limit during the start-up (Start and trip is blocked). To cancel this block, frequency has to rise above the set limit.

**Table 6.40: Underfrequency  $f <$ ,  $f < <$  (81L) Underfrequency stages  $f <$ ,  $f < <$  (81L)**

Input signal	$U_{L1} - U_{L3}$
Frequency measuring area	16.0 – 75.0 Hz
Current and voltage meas. range	45.0 – 65.0 Hz
Frequency stage setting range	40.0 – 64.0 Hz
Low voltage blocking	10 – 100 % $U_N$
Definite time function: - operate time	0.10** – 300.0 s (step 0.02 s)
Undervoltage blocking	2 – 100 %
Start time	< 100 ms
Reset time	<120 ms
Reset ratio	>1.002
Reset ratio (LV block)	Instant (no hysteresis)
Inaccuracy: - Starting - starting (LV block) - operate time	$\pm 20$ mHz 3% of the set value or $\pm 0.5$ V $\pm 1\%$ or $\pm 30$ ms

\*\*\*) This is the instantaneous time i.e. the minimum total operational time including the fault detection time and operate time of the trip contacts.

## 6.27 Rate of change of frequency (ANSI 81R)

### Description

The rate of change of frequency (ROCOF or  $df/dt$ ) function is used for fast load shedding, to speed up operate time in overfrequency and underfrequency situations and to detect loss of grid. For example, a centralized dedicated load shedding relay can be omitted and replaced with distributed load shedding, if all outgoing feeders are equipped with Easergy P3 relays.

A special application for ROCOF is to detect loss of grid (loss of mains, islanding). The more the remaining load differs from the load before the loss of grid, the better the ROCOF function detects the situation.

### Frequency behaviour during load switching

Load switching and fault situations may generate change in frequency. A load drop may increase the frequency and increasing load may decrease the frequency, at least for a while. The frequency may also oscillate after the initial change. After a while, the control system of any local generator may drive the frequency back to the original value. However, in case of a heavy short-circuit fault or if the new load exceeds the generating capacity, the average frequency keeps on decreasing.

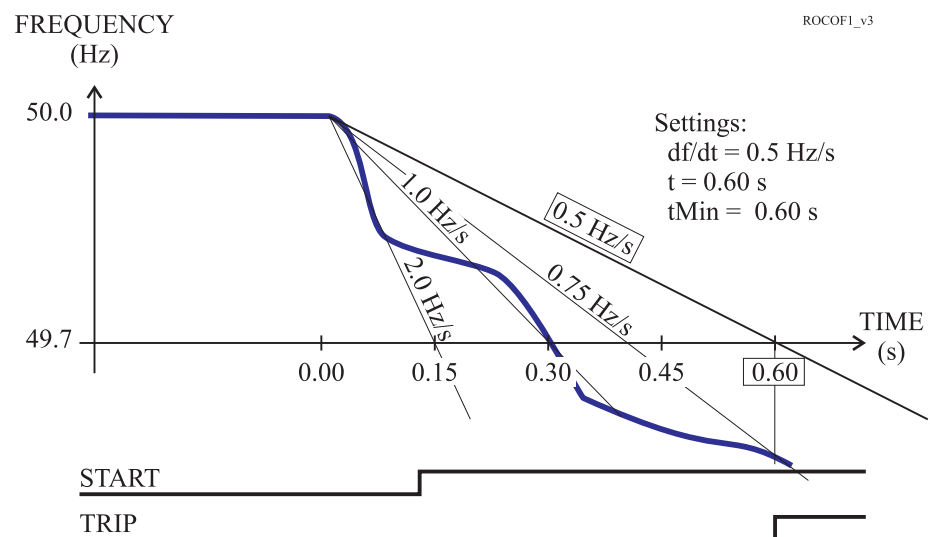

Figure 6.69: An example of definite time  $df/dt$  operate time. At 0.6 s, which is the delay setting, the average slope exceeds the setting 0.5 Hz/s and a trip signal is generated.

### ROCOF implementation

The ROCOF function is sensitive to the absolute average value of the time derivate of the measured frequency  $|df/dt|$ . Whenever the measured frequency slope  $|df/dt|$  exceeds the setting value for 80 ms time, the ROCOF stage starts and issues a start signal after an

additional 60 ms delay. If the average  $|df/dt|$ , since the start moment, still exceeds the setting, when the operation delay has elapsed, a trip signal is issued. In this definite time mode the second delay parameter "minimum delay,  $t_{MIN}$ " must be equal to the operation delay parameter "t".

If the frequency is stable for about 80 ms and the time t has already elapsed without a trip, the stage resets.

### ROCOF and overfrequency and underfrequency stages

One difference between the overfrequency and underfrequency and the  $df/dt$  function is the speed. Often a  $df/dt$  function can predict an overfrequency or underfrequency situation and is thus faster than a simple overfrequency or underfrequency function. However, in most cases, standard overfrequency and underfrequency stages must be used together with ROCOF to ensure tripping also if the frequency drift is slower than the slope setting of ROCOF.

### Definite operate time characteristics

Figure 6.69 shows an example where the  $df/dt$  start value is 0.5 Hz/s and the delay settings are  $t = 0.60$  s and  $t_{MIN} = 0.60$  s. Equal times  $t = t_{MIN}$  gives a definite time delay characteristic. Although the frequency slope fluctuates, the stage does not release but continues to calculate the average slope since the initial start. At the defined operate time,  $t = 0.6$  s, the average slope is 0.75 Hz/s. This exceeds the setting, and the stage trips.

At slope settings less than 0.7 Hz/s, the fastest possible operate time is limited according to the Figure 6.70.

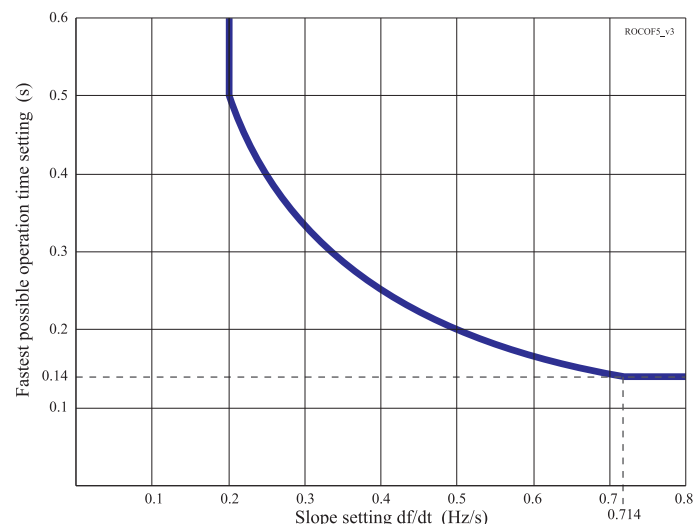

Figure 6.70: At very sensitive slope settings the fastest possible operate time is limited.



### Dependent operate time characteristics

By setting the second delay parameter  $t_{MIN}$  smaller than the operate time delay  $t$ , a dependent type of operate time characteristic is achieved.

Figure 6.72 shows one example, where the frequency behaviour is the same as in the first figure, but the  $t_{MIN}$  setting is 0.15 s instead of being equal to  $t$ . The operate time depends on the measured average slope according to the following equation:

Equation 6.10:

$$t_{TRIP} = \frac{s_{SET} \cdot t_{SET}}{|s|}$$

$t_{TRIP}$  = Resulting operate time (seconds).

$s_{SET}$  =  $df/dt$  i.e. slope setting (hertz/seconds).

$t_{SET}$  = Operate time setting  $t$  (seconds).

$s$  = Measured average frequency slope (hertz/seconds).

The minimum operate time is always limited by the setting parameter  $t_{MIN}$ . In the example, the fastest operate time, 0.15 s, is achieved when the slope is 2 Hz/s or more. The leftmost curve in Figure 6.71 shows the dependent characteristics with the same settings as in Figure 6.72.

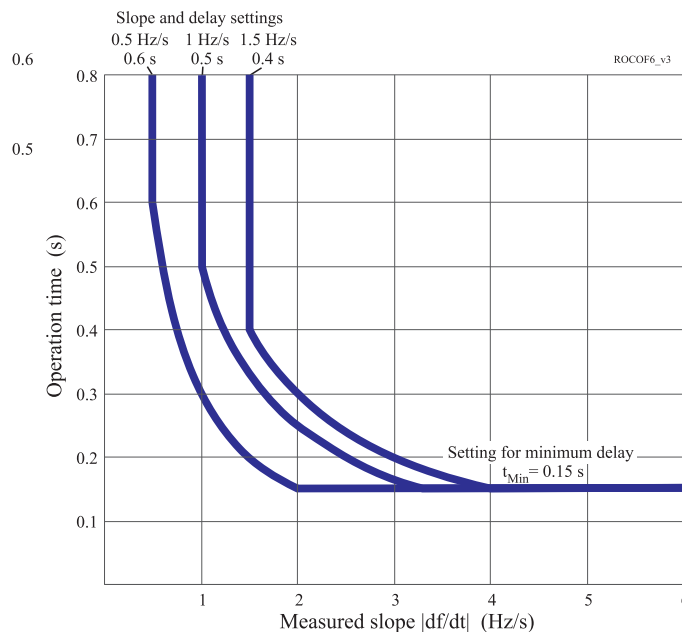

Figure 6.71: Three examples of possible dependent  $df/dt$  operate time characteristics. The slope and operation delay settings define the knee points on the left. A common setting for  $t_{Min}$  has been used in these three examples. This minimum delay parameter defines the knee point positions on the right.

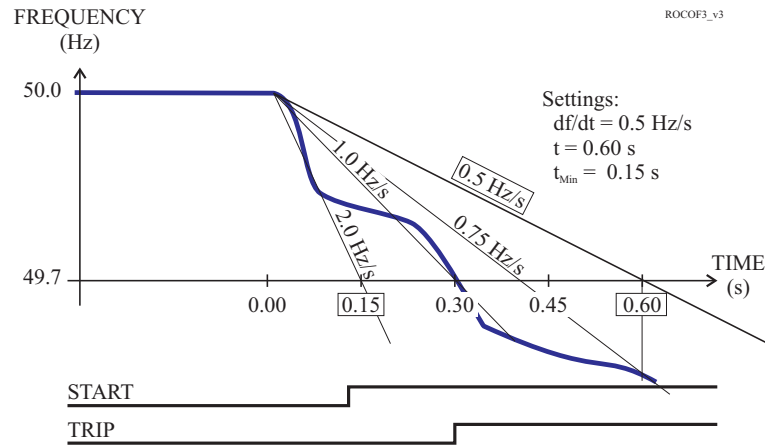

Figure 6.72: An example of dependent  $df/dt$  operate time. The time to trip will be 0.3 s, although the setting is 0.6 s, because the average slope 1 Hz/s is steeper than the setting value 0.5 Hz/s.

### Setting groups

There are four setting groups available.

### Characteristics

Table 6.41: Rate of change of frequency  $df/dt >$  (81R)

Start setting $df/dt$	0.2 – 10.0 Hz/s (step 0.1 Hz/s)
Definite time delay ( $t >$ and $t_{\text{Min}} >$ are equal): - Operate time $t >$	0.14** – 10.00 s (step 0.02 s)
Dependent time delay ( $t >$ is more than $t_{\text{Min}} >$ ): - Minimum operate time $t_{\text{Min}} >$	0.14** – 10.00 s (step 0.02 s)
Start time	Typically 140 ms
Reset time	150 ms
Overshoot time	< 90 ms
Reset ratio	1
Inaccuracy: - Starting - Operate time (overshoot $\geq 0.2 \text{ Hz/s}$ )	10% of set value or $\pm 0.1 \text{ Hz/s}$ $\pm 35 \text{ ms}$ , when area is 0.2 – 1.0 Hz/s

**NOTE:** ROCOF stage is using the same low voltage blocking limit as the frequency stages.

\*\*\*) This is the instantaneous time i.e. the minimum total operational time including the fault detection time and operate time of the trip contacts.

## 6.28 Lockout (ANSI 86)

### Description

The lockout feature, also called latching, can be programmed for outputs in the OUTPUT MATRIX setting view. Any protection stage start or trip, digital input, logic output, alarm and GOOSE signal connected to the following outputs can be latched when required:

- output contacts T1 – T7, A1
- LEDs on the front panel
- virtual outputs VO1- VO20

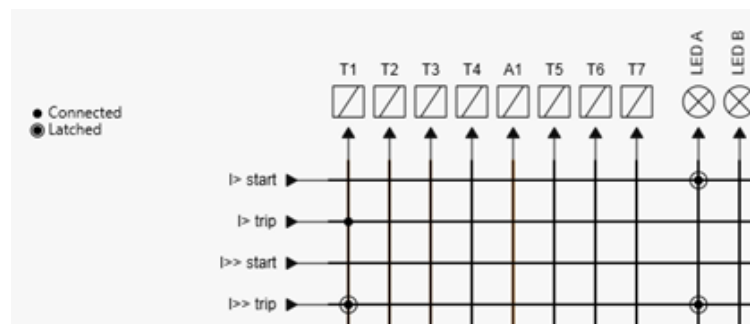

Figure 6.73: The lockout programmed for LED A and I>> trip signals. The latched signal is identified with a dot and circle in the matrix signal line crossing.

The lockout can be released through the display or via the Easergy Pro. See Chapter 5 Control functions.

Set the relay output, LED and virtual output latches to restore to their original state detected before the power off by selecting the **Store latch state** checkbox in the **General > Release latches** setting view.

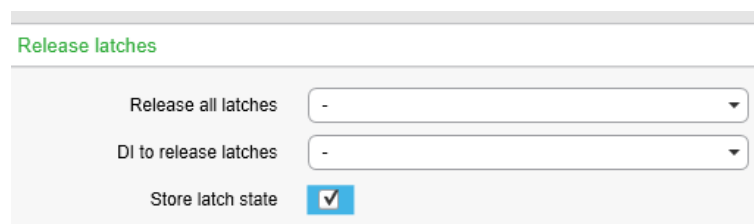

Figure 6.74: Store latch setting view

## 6.29 Differential overcurrent protection (ANSI 87M)

### Description

The differential overcurrent protection comprises of two separately adjustable stages, stage  $\Delta I >$  and stage  $\Delta I >>$ .

The differential protection is based on the winding currents difference between IL and I'L side. In transformer applications, the current calculation depends on transformer connection group. For example, in a Yy0 connection, the measured currents are also winding currents, see Figure 6.75. In motor applications, the connection group is always Yy0 and measured currents are also winding currents.

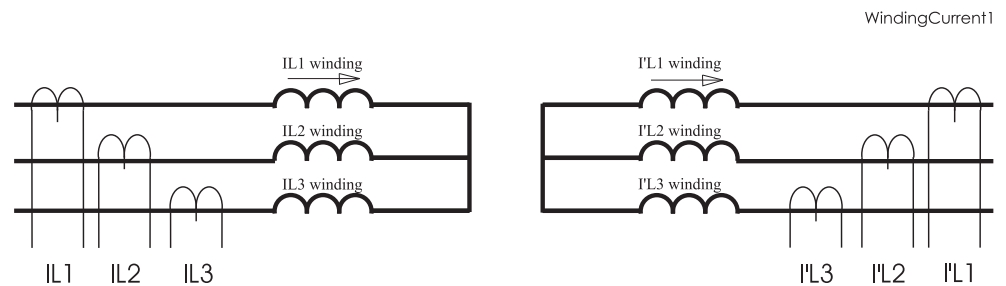

Figure 6.75: Winding currents in connection group Yy0

In the second example, if the transformer IL side is connected to open delta for example Dy11, then the winding currents are calculated on the delta side (IL side), see Figure 6.76.

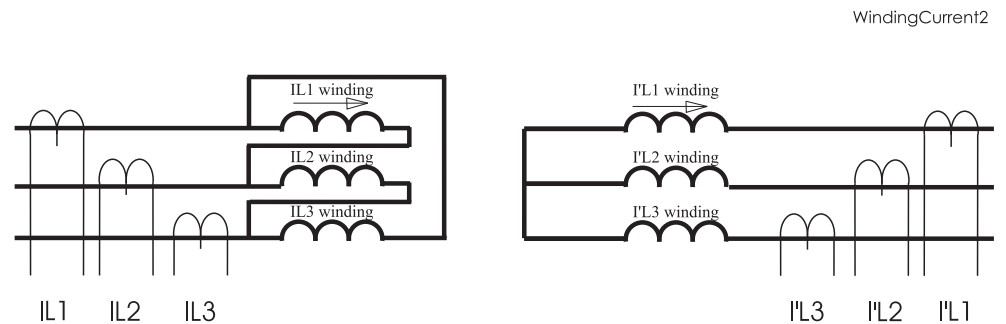

Figure 6.76: Winding currents in connection group Dy11

Equation 6.11: Winding current calculation in delta side, Dy11 connection

$$\frac{\overline{I_{L1W}}}{\sqrt{3}} = \left( \overline{I_{L1}} - \overline{I_{L2}} \right)$$

$$\frac{\overline{I_{L2W}}}{\sqrt{3}} = \left( \overline{I_{L2}} - \overline{I_{L3}} \right)$$

$$\frac{\overline{I_{L3W}}}{\sqrt{3}} = \left( \overline{I_{L3}} - \overline{I_{L1}} \right)$$

Equation 6.12: Winding currents in star side, Dy11 connection

$$\overline{I'_{L1W}} = \overline{I'_{L1}}$$

$$\overline{I'_{L2W}} = \overline{I'_{L2}}$$

$$\overline{I'_{L3W}} = \overline{I'_{L3}}$$

Equation 6.13: Bias current

$$I_b = \frac{|\overline{I_W}| + |\overline{I'_{W}}|}{2}$$

Equation 6.14: Differential current

$$I_d = \left| \overline{I_W} + \overline{I'_{W}} \right|$$

Bias current calculation is only used in protection stage  $\Delta I >$ . Bias current describes the average current flow in the transformer. Bias and differential currents are calculated individually for each phase.

If the transformer is earthed, for example having the connection group Dyn11, then zero current must be compensated before differential and bias current calculation. Zero current compensation can be selected individually for the IL and I'L side.

Table 6.42 describes the connection group and zero current compensation for different connection groups. If the protection area is only generator, then the connection group setting is always Yy0, see Table 6.43. Also the settings of Un and U'n are set to be the same, for example generator nominal voltage.

**Table 6.42: Zero current compensation in transformer applications**

Transformer	Relay setting		
Connection group	ConnGrp	Io cmps	I'o cmps
YNy0	Yy0	ON	OFF
YNyn0	Yy0	ON	ON
Yy0	Yy0	OFF	OFF
Yyn0	Yy0	OFF	ON
YNy6	Yy6	ON	OFF
YNyn6	Yy6	ON	ON
Yy6	Yy6	OFF	OFF
Yyn6	Yy6	OFF	ON
Yd1	Yd1	OFF	OFF
YNd1	Yd1	ON	OFF
Yd5	Yd5	OFF	OFF
YNd5	Yd5	ON	OFF
Yd7	Yd7	OFF	OFF
YNd7	Yd7	ON	OFF
Yd11	Yd11	OFF	OFF
YNd11	Yd11	ON	OFF
Dy1	Dy1	OFF	OFF
Dyn1	Dy1	OFF	ON
Dy5	Dy5	OFF	OFF
Dyn5	Dy5	OFF	ON
Dy7	Dy7	OFF	OFF
Dyn7	Dy7	OFF	ON
Dy11	Dy11	OFF	OFF
Dyn11	Dy11	OFF	ON

**Table 6.43: Zero current compensation in generator applications**

Generator only	Relay setting		
	ConnGrp	Io cmps	I'o cmps
No earthing	Yy0	OFF	OFF

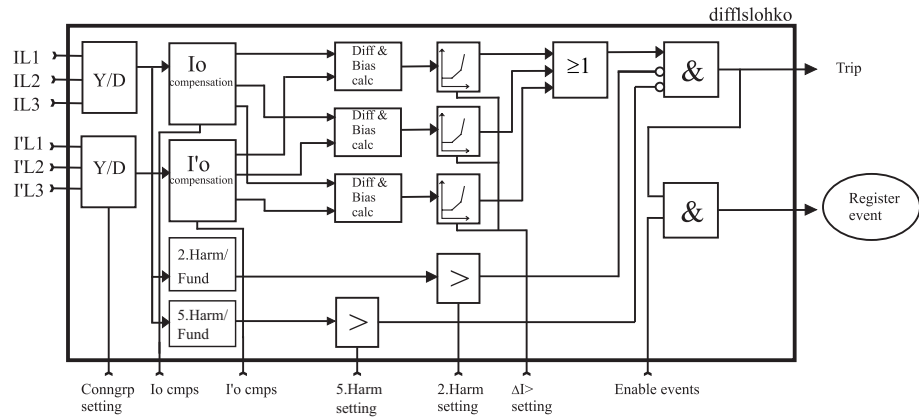

Figure 6.77: Block diagram of the differential overcurrent stage  $\Delta I >$

The stage  $\Delta I >$  can be configured to operate as shown in Figure 6.78. This dual slope characteristic allows more differential current at higher currents before tripping.

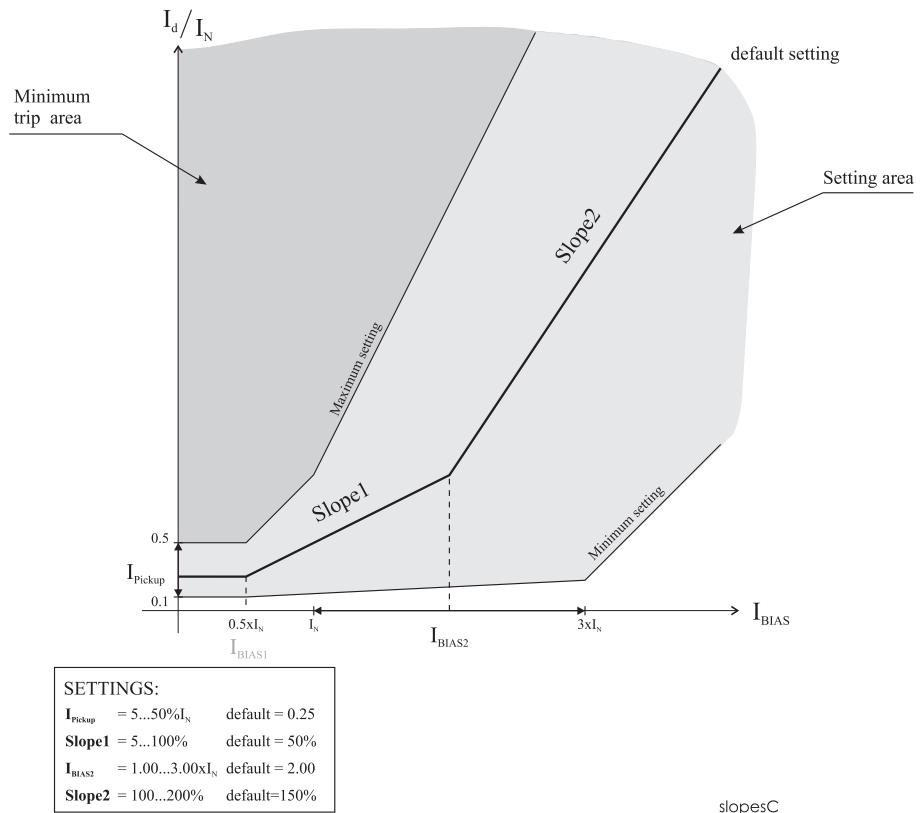

Figure 6.78: Example of differential overcurrent characteristics

The stage also includes second harmonic blocking. The second harmonic is calculated from winding currents. Harmonic ratio is:

$$100 \times I_{f2\_Winding} / I_{f1\_Winding} [\%].$$

The fast differential overcurrent stage  $\Delta I >>$  does not include slope characteristics or second harmonics blocking.

### Differential Protection using 6 CTs

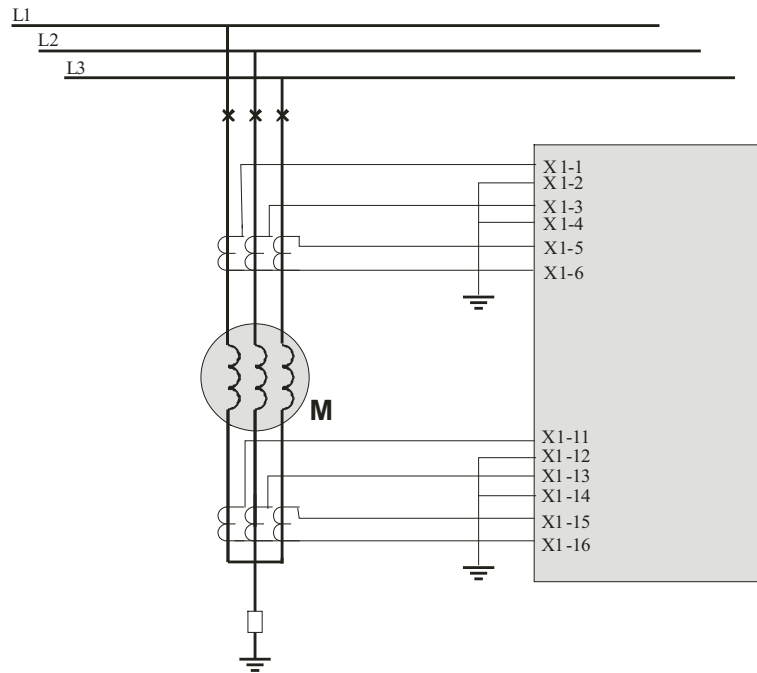

Figure 6.79: Easergy P3M30 and P3M32 connected as a motor differential protection using 6 CTs.

In this application mode the settings in Easergy P3M30 and P3M32 relay's menu SCALING should be set as described in the following section.

#### CT settings

Here the motor high and low side primary and secondary CT ratings are set according to the actual CT ratios.

Set motor nominal current.

#### Settings of the differential protection

$\Delta I > 87$  function shall be enabled for differential protection.

$\Delta I >$  pick-up setting range is user selectable from 5 % to 50 %.

Slope 1 can be set to 5 %.

$I_{BIAS}$  for start of slope 2 can be set to  $3 \times I_N$

Slope 2 can be set to 50 %.

If CTs are saturating at through faults, the Slope 2 settings must be changed accordingly.

$\Delta I >$  2nd harmonic block enable can be set OFF (disabled).

$\Delta I >$  2nd harmonic block limit can be disregarded and the factory default setting can be left intact.



### Motor differential protection using flux balancing principle

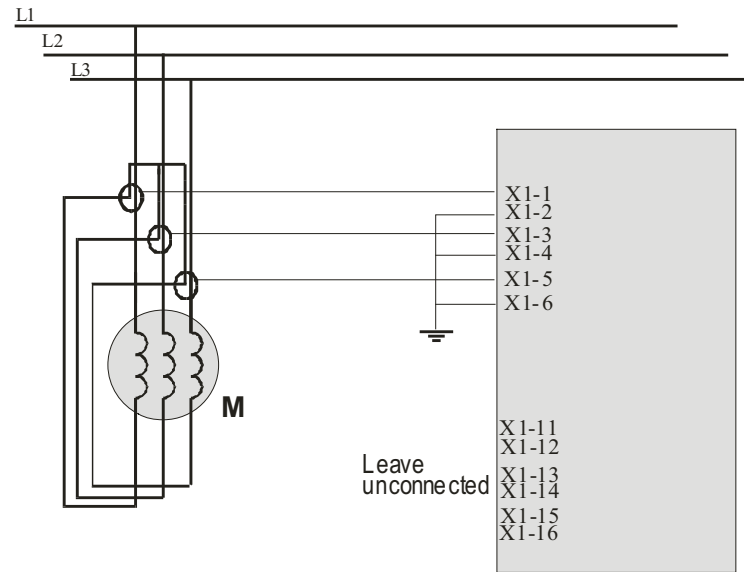

Figure 6.80: Easergy P3M30 and P3M32 connected as a motor differential protection using 3 core balance CT's connected using flux balancing principle.

In this application mode the settings in Easergy P3M30 and P3M32 relay's menu SCALING should be set as described in the following section.

**NOTE:** If motor protection functions are used, connect the differential connection to the LV side CT inputs (I'L1, I'L2, I'L3).

#### CT Settings

CT Primary and CT Secondary settings shall be set according to the actual core balance CT ratios.

CT' Primary and CT' Secondary settings can be disregarded and the factory default settings can be left intact.

Set motor nominal current.

#### Settings of the differential protection

$\Delta I > 87$  function shall be enabled for differential protection.

$\Delta I >$  pick-up setting range is user selectable from 5 % to 50 %.

Slope 1 can be set to 5 %.

$I_{BIAS}$  for start of slope 2 can be set to  $3 \times I_N$ .

Slope 2 can be set to 50 %.

$\Delta I >$  2nd harmonic block enable can be set OFF (disabled).

$\Delta I >$  2nd harmonic block limit can be disregarded and the factory default setting can be left intact.

### Current transformer supervision

The current transformer supervision (CTS) feature is used to detect a failure of one or more of the phase current inputs to the relay. Failure of a phase CT or an open circuit of the interconnecting wiring can result in incorrect operation of any current-operated element. Additionally, interruption in the current circuit generates dangerous CT secondary voltages.

The screenshot shows the following settings:

- Differential CTS:
- Operation mode: Restrain
- I1 limit: 0.05 xIn
- I1 limit: 50 A
- I2/I1 limit: 30%

Figure 6.81: Current transformer supervision settings

The differential CTS method uses the ratio between positive and negative sequence currents at both ends of the protected line to determine a CT failure. This algorithm relies on ANSI85 communication and is inbuilt in the LdI> stage.

When this ratio is small (zero), one of four conditions is present:

- The system is unloaded – both I2 and I1 are zero
- The system is loaded but balanced – I2 is zero
- The system has a 3-phase fault – I2 is zero
- There is a 3-phase CT failure – unlikely to happen

When the ratio is non-zero, one of the following two conditions is present:

- The system has an asymmetric fault – both I2 and I1 are non-zero
- There is a 1 or 2 phase CT fault – both I2 and I1 are non-zero

The I2 to I1 ratio is calculated at both ends of the protected line. Both relays calculate their own ratio and the other end's ratio using their own measurements and measurements received via ANSI85. With this information, we can assume that:

- If the ratio is non-zero at both ends, there is a real fault in the network and the CTS should not operate.
- If the ratio is non-zero only at one end, there is a change of CT failure and the CTS should operate.

Another criterion for CTS is to check whether the differential system is loaded or not. For this purpose, the positive sequence current I1 is checked at both ends. If load current is detected only at one end, it is assumed that there is an internal fault condition and CTS is prevented from operating, but if load current is detected at both line ends, CTS operation is permitted.

There are three modes of operation:

- indication mode: CTS alarm is raised but there is no effect on tripping
- restrain mode: an alarm is raised and the differential current percentage setting value increased by 100 (for example 30 % + 100 % = 130 %). The new value is theoretically the maximum amount of differential current that a CT failure can produce in a normal full-load condition.
- block mode: an alarm is raised and differential protection is prevented from tripping

The differential CTS block mode is not recommended for two reasons:

- If there is a real fault during a CT failure, the differential protection would not protect the line at all.
- Blocking the protection could slow down the operate time of the differential protection because of transients in the beginning of the fault on the protected line.

### Setting groups

This stage has one setting group.

### Characteristics

**Table 6.44: Differential overcurrent stage  $\Delta I >$  (87)**

Start value	5 – 50 % $I_N$
Bias current for start of slope 1	0.50 x $I_N$
Slope 1	5 – 100 %
Bias current for start of slope 2	1.00 – 3.00 x $I_N$
Slope 2	100 – 200 %
Second harmonic blocking	5 – 30 %, or disable
Fifth harmonic blocking	20 – 50 %, or disable
Reset time	< 95 ms
Reset ratio	0.95
Inaccuracy:	
- Second harmonic blocking	±2% - unit
- Fifth harmonic blocking	±3% - unit
- Starting	±3% of set value or 0.02 x $I_N$ when currents are < 200 mA
- Operate time ( $I_D > 1.2 \times I_{SET}$ )	< 60 ms
- Operate time ( $I_D > 3.5 \times I_{SET}$ )	< 50 ms

**Table 6.45: Differential overcurrent stage  $\Delta I >>$  (87)**

Start value	$5.0 - 40.0 \times I_N$
Reset time	< 95 ms
Reset ratio	0.95
Inaccuracy:	
- Starting	$\pm 3\%$ of set value or $\pm 0.5\%$ of rated value
- Operate time ( $I_D > 3.5 \times I_{SET}$ )	< 40 ms

## 6.30 Arc flash protection (AFD)

### 6.30.1 Arc flash protection, general principle

The arc flash protection contains 8 arc stages that can be used to trip for example the circuit breakers. Arc stages are activated with overcurrent and light signals (or light signals alone). The allocation of different current and light signals to arc stages is defined in arc flash protection matrices: current, light and output matrix. The matrices are programmed via the arc flash protection menus. Available matrix signals depend on the order code (see Chapter 13 Order code).

Available signal inputs and outputs for arc protection depend on the relay's hardware configuration.

### 6.30.2 Arc flash protection menus

The arc flash protection menus are located in the main menu under ARC. The ARC menu can be viewed either on the front panel, or by using Easergy Pro.

#### Arc protection

The screenshot shows the 'ARC PROTECTION' menu with the following details:

- Settings:**
  - I>int. pick-up setting: 1200 A
  - I>int. pick-up setting: Slider control with value 1.20 xIn
  - Io1>int. pick-up setting: 12 A
  - Io1>int. pick-up setting: Slider control with value 1.20 xIn
  - Install arc sensors: - (dropdown menu)
  - Installation state: Ready
- Current measurement states:**

Measurement	State
I>int.	0
Io1>int.	0
- Arc Stages:**

Stage	Stage Enabled	Trip delay [x1ms]	Min. hold time [x10ms]	State	DI to block stage
1	Off	0	2	0	-
2	Off	0	2	0	-
3	Off	0	2	0	-
4	Off	0	2	0	-
5	Off	0	2	0	-
6	Off	0	2	0	-
7	Off	0	2	0	-
8	Off	0	2	0	-

Figure 6.82: Example view of Arc protection

**Table 6.46: Arc protection parameter group**

Item	Default	Range	Description
I>int. start setting	1.00 xIn	0.50–8.00 x In	Phase L1, L2, L3 overcurrent start level
Io>int. start setting	1.00 xIn	0.10–5.00 x In	Residual overcurrent start level
Install arc sensors	-	-, Install	Installs all connected sensors
Installation state	Ready	Installing, Ready	Installation state
Link Arc selfdiag to SF relay	On	On, Off	Links Arc protection selfsupervision signal to SF relay
Stage Enabled	On or Off	On, Off	Enables the arc protection stage
Trip delay [ms]	0	0–255	Trip delay for the arc protection stage
Min. hold time [10ms]	2	2–255	Minimum trip pulse length for the arc protection stage (Overshoot time <35ms)

**NOTE:** Use trip delay for a separate arc stage as circuit breaker failure protection (CBFP).

**Arc matrix – current**

In the **Arc matrix – current** setting view, the available current signals (left column) are linked to the appropriate arc stages (1–8).

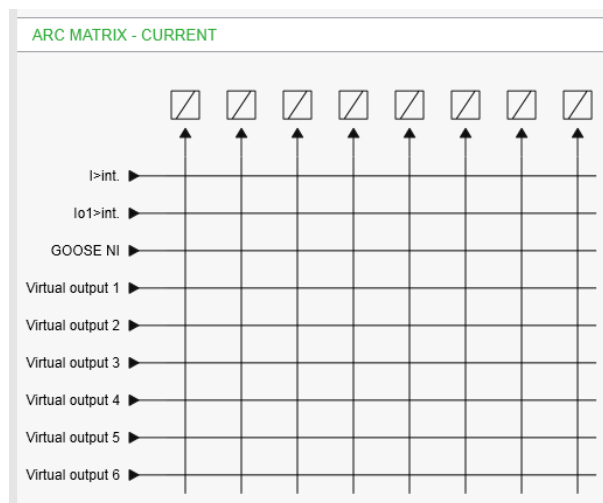

**Figure 6.83: Example view of Arc matrix – current**

**Table 6.47: Arc matrix – current parameter group**

Item	Default	Range	Description
I>int.	-	On, Off	Phase L1, L2, L3 internal overcurrent signal
Io>int.	-	On, Off	Residual overcurrent signal
GOOSE NI	-	On, Off	Goose network input
Virtual output 1 – 6	-	On, Off	Virtual output
Arc stage 1 – 8	-	On, Off	Arc protection stage 1–8

### Arc matrix – light

In the **Arc matrix – light** setting view, the available arc light signals (left column) are linked to the appropriate arc stages (1–8).

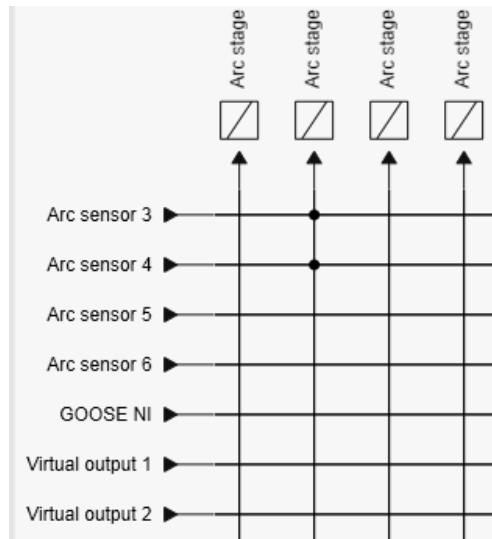

Figure 6.84: Example view of Arc matrix – light

Table 6.48: Arc matrix – light parameter group

Item	Default	Range	Description
Arc_matrix_light	-	On, Off	Internal arc flash sensor 1–10
GOOSE NI	-	On, Off	Goose network input
Virtual output 1 – 6	-	On, Off	Virtual output
Arc stage 1 – 8	-	On, Off	Arc protection stage 1–8

### Arc matrix – output

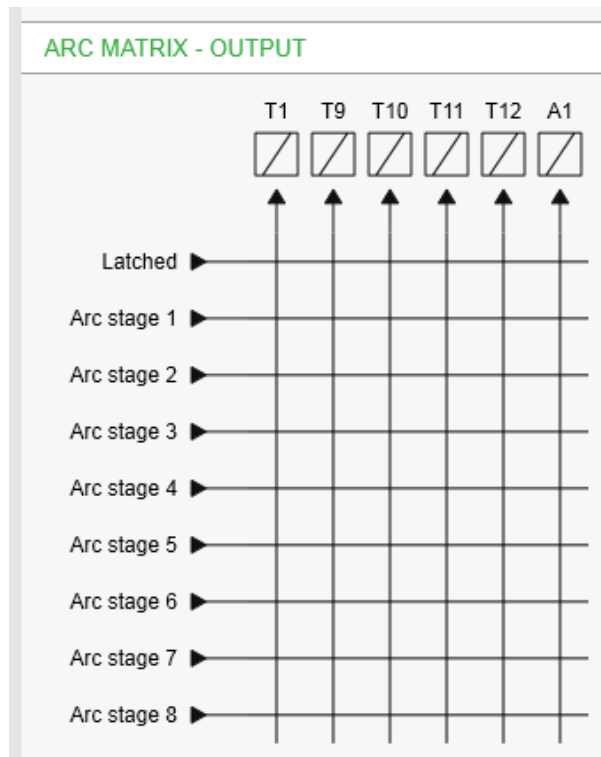

Figure 6.85: Example view of **Arc matrix – output**

In the **Arc matrix – output** setting view, the used Arc stages (1–8) are connected to the required outputs. A possible latched function per output is also determined in this view. The available outputs depend on the order code.

The matrix connection done in the **Arc matrix – output** view also becomes visible in the output matrix.

Table 6.49: **Arc matrix – output parameter group**

Item	Default	Range	Description
Latched	-	On, Off	Output latch
Arc stage 1–8	-	On, Off	Arc protection stage 1–8
T1–4	-	On, Off	Trip digital output 1–4
A1	-	On, Off	Signal alarm relay 1

### MATRIX correlation principle

When determining the activating conditions for a certain arc stage, a logical AND operator is made between the outputs from the arc light matrix and arc current matrix.

If an arc stage has selections in only one of the matrixes, the stage operates on a light-only or on current-only principle.



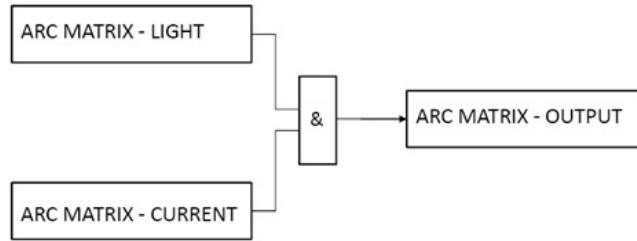

Figure 6.86: Matrix correlation principle with the logical AND operator

### Arc event enabling

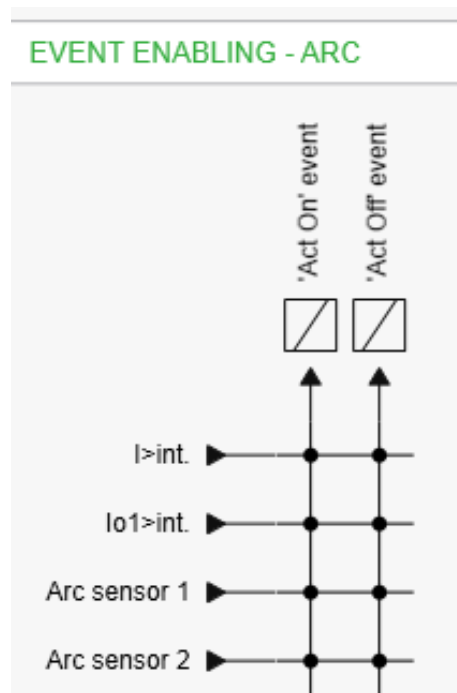

Figure 6.87: Example view of Arc event enabling

Table 6.50: Arc event enabling parameter group

Item	Default	Range	Description
I>int.	On	On, Off	Internal I overcurrent signal
Io>int.	On	On, Off	Internal Io overcurrent signal
Arc sensor 1 – 2	On	On, Off	Arc flash sensor 1–2
Arc stage 1 – 8	On	On, Off	Arc protection stage 1–8
'Act On' event	On	On, Off	Event enabling
'Act Off' event	On	On, Off	Event enabling

## 6.30.3 Example of arc flash protection configuration

### Installing the arc flash sensors

1. Go to **Protection > Arc protection**.
2. Under **Settings**, click the **Install arc sensors** drop-down list and select **Install**.
3. Wait until the **Installation state** shows **Ready**. The communication between the system components is created.
4. The installed sensors and units can be viewed at the bottom of the **ARC PROTECTION** group view.

#### Local Arc Sensors Installed

Sensor	Arc sensor status
3	OK
4	OK
5	OK
6	OK

On the Easergy Pro group list, select ARC PROTECTION.

5. Click the Arc Stages 1, 2, and select Stage 1 and 2 'On'.
6. Click the Trip delay[ms] value, set it to for example '0' and press Enter.
7. Click the DI block value, set it to for example '-' and press Enter.

### Configuring the current start values

The **General > Scaling** setting view contains the primary and secondary values of the CT. However, the **Arc protection** menu calculates the primary value only after the **I start setting** value is given.

For example:

1. Go to **General > Scaling**.
2. Click the **CT primary** value, set it to for example *1200 A* and press **Enter**.
3. Click the **CT secondary** value, set it to for example *5 A* and press **Enter**.
4. On the Easergy Pro group list, select **Protection > Arc protection**.
5. Define the **I start setting** value for the relay.
6. Define the **Io start setting** in a similar manner.

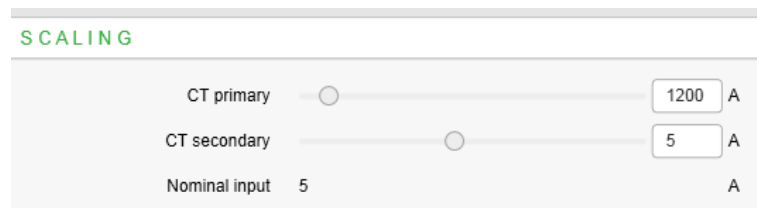

Figure 6.88: Example of setting the current transformer scaling values

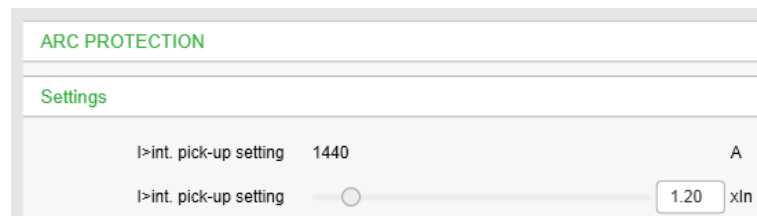

Figure 6.89: Example of defining the I start setting value

### Configuring the current matrix

Define the current signals that are received in the arc flash protection system's relay. Connect currents to Arc stages in the matrix.

For example:

The arc flash fault current is measured from the incoming feeder, and the current signal is linked to **Arc stage 1** in the current matrix.

1. Go to **Matrix > Arc matrix - Current**
2. In the matrix, select the connection point of **Arc stage 1** and **I>int.**
3. On the **Communication** menu, select **Write Changed Settings To Device.**

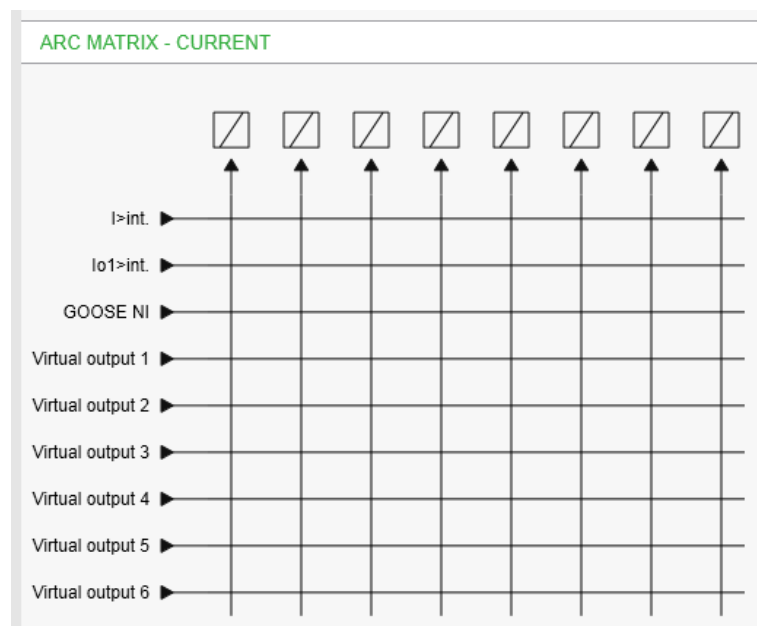

Figure 6.90: Configuring the current matrix – an example

### Configuring the light matrix

Define what light sensor signals are received in the protection system. Connect the light signals to the arc stages in the matrix.

For example:

1. Go to **Matrix > Arc matrix - Light**
2. In the matrix, select the connection point of **Arc sensor 1** and **Arc stage 2**.
3. Select the connection point of **Arc sensor 2** and **Arc stage 2**.
4. On the **Communication** menu, select **Write Changed Settings To Device**.

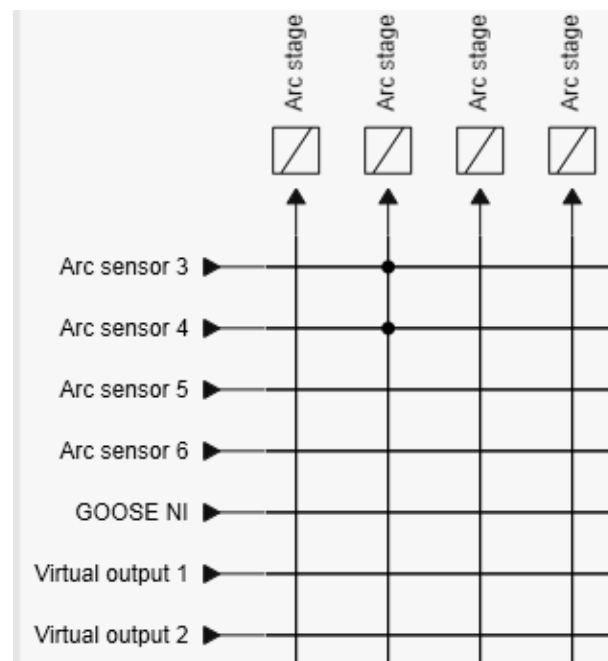

Figure 6.91: Configuring the light arc matrix

### Configuring the output matrix

Define the trip relays that the current and light signals affect.

For example:

1. Go to **Matrix > Arc matrix - Output**
2. In the matrix, select the connection point of **Arc stage 1** and **T1**.
3. Select the connection points of **Latched** and **T1** and **T9**.
4. Select the connection point of **Arc stage 2** and **T9**.
5. On the **Communication** menu, select **Write Changed Settings To Device**.

**NOTE:** It is recommended to use latched outputs for the trip outputs.  
Arc output matrix includes only outputs which are directly controlled by FPGA.

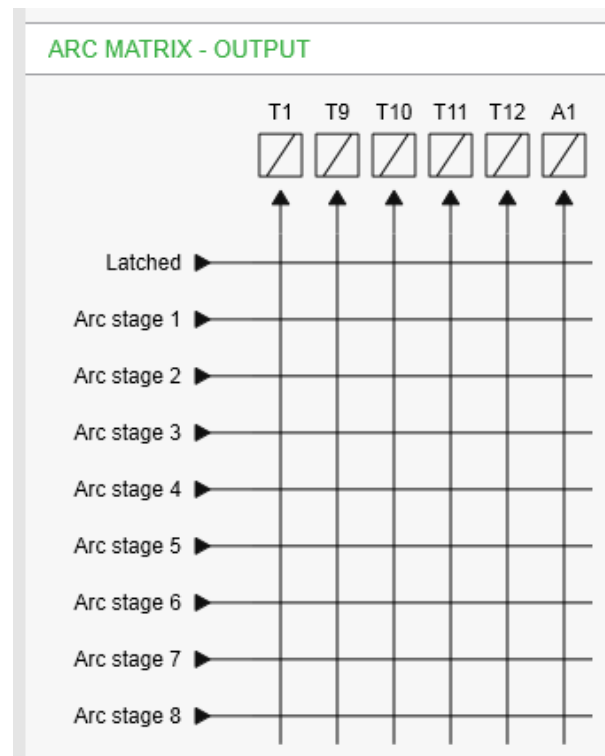

Figure 6.92: Configuring the output matrix - an example

### Configuring the arc events

Define which arc events are written to the event list in this application.  
For example:

1. Go to **Logs > Event enabling - Arc**
2. In the matrix, enable both '**Act On**' event and '**Act Off**' event for **Arc sensor 1**, **Arc stage 1**, and **Arc stage 2**.
3. On the **Communication** menu, select **Write Changed Settings To Device**.

#### EVENT ENABLING - ARC

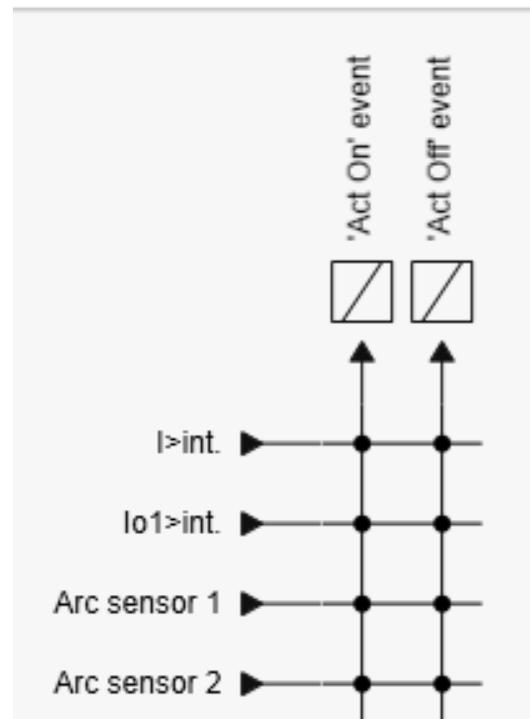

Figure 6.93: Configuring the arc events – an example

## 6.30.4 Arc fault protection (optional)

The operation of the arc protection depends on the setting value of the  $I > \text{int}$  and  $I_0 1 > \text{int}$  current limits.

The arc current limits cannot be set, unless the relay is provided with the optional arc protection card.

### Characteristics

**Table 6.51: Arc protection stage**

Start value ( $I > \text{int}$ )	0.5–8.0 x $I_N$
Start value ( $I_0 1 > \text{int}$ )	0.1–5.0 x $I_n$
Operate time	T1, T9–T12
- Light only	≤9 ms
- 4 x $I_{\text{set}}$ and light	≤9 ms
- Arc stage delay	0 – 255 ms
Inaccuracy:	
- Starting ( $I > \text{int}$ , $I_0 1 > \text{int}$ )	10% of the set value



## 6.31 Programmable stages (ANSI 99)

### Description

For special applications, you can build your own protection stages by selecting the supervised signal and the comparison mode.

The following parameters are available:

- **Priority**  
If operate times less than 80 milliseconds are needed, select 10 ms. For operate times under one second, 20 ms is recommended. For longer operation times and THD signals, 100 ms is recommended.
- **Coupling A**  
The selected supervised signal in “>” and “<” mode. The available signals are shown in the table below.
- **Coupling B**  
The selected supervised signal in "Diff" and "AbsDiff" mode. This selection becomes available once "Diff" or "AbsDiff" is chosen for Coupling A.
- **Compare condition**  
Compare mode. ‘>’ for over or ‘<’ for under comparison, “Diff” and “AbsDiff” for comparing Coupling A and Coupling B.
- **AbsDiff | d |**  
Coupling A – coupling B. The stage activates if the difference is greater than the start setting.
- **Diff d**  
Coupling A – coupling B. The stage activates if the sign is positive and the difference greater than the start setting.
- **Start**  
Limit of the stage. The available setting range and the unit depend on the selected signal.
- **Operation delay**  
Definite time operation delay
- **Hysteresis**  
Dead band (hysteresis). For more information, see Chapter 6.2 General features of protection stages.
- **No Compare limit for mode <**  
Only used with compare mode under (‘<’). This is the limit to start the comparison. Signal values under NoCmp are not regarded as fault.

**Table 6.52: Available signals to be supervised by the programmable stages**

IL1, IL2, IL3	Phase currents (RMS values)
Io	Earth fault overcurrent
U12, U23, U31	Line-to-line voltages
UL1, UL2, UL3	Line-to-neutral voltages
Uo	Neutral displacement voltage
f	Frequency
P	Active power
Q	Reactive power
S	Apparent power
Cos Phi	Cosine $\phi$
IoCalc	Phasor sum $I_{L1} + I_{L2} + I_{L3}$
I1	Positive sequence current
I2	Negative sequence current
I2/I1	Relative negative sequence current
I2/In	Negative sequence current in pu
U1	Positive sequence overvoltage
U2	Negative sequence overvoltage
U2/U1	Relative negative sequence voltage
IL	Average $(I_{L1} + I_{L2} + I_{L3}) / 3$
Tan Phi	Tangent $\phi$ [= $\tan(\arccos\phi)$ ]
PRMS	Active power RMS value
QRMS	Reactive power RMS value
SRMS	Apparent power RMS value
THDIL1	Total harmonic distortion of $I_{L1}$
THDIL2	Total harmonic distortion of $I_{L2}$
THDIL3	Total harmonic distortion of $I_{L3}$
THDU <sub>A</sub>	Total harmonic distortion of input U <sub>A</sub>
THDU <sub>B</sub>	Total harmonic distortion of input U <sub>B</sub>
THDU <sub>C</sub>	Total harmonic distortion of input U <sub>C</sub>
fy	Frequency behind circuit breaker
fz	Frequency behind 2nd circuit breaker
IL1RMS	IL1 RMS for average sampling
IL2RMS	IL2 RMS for average sampling
IL3RMS	IL3 RMS for average sampling
ILmin, ILmax	Minimum and maximum of phase currents
ULNmin, ULNmax	Minimum and maximum of line-to-line voltages
VAI1, VAI2, VAI3, VAI4, VAI5	Virtual analog inputs 1, 2, 3, 4, 5 (GOOSE)

Signals available depending on slot 8 options.

**Eight independent stages**

The relay has eight independent programmable stages. Each programmable stage can be enabled or disabled to fit the intended application.

**Setting groups**

There are four settings groups available.

See Chapter 6.2 General features of protection stages for more details.

# 7 Supporting functions

## 7.1 Event log

Event log is a buffer of event codes and time stamps including date and time. For example, each start-on, start-off, trip-on or trip-off of any protection stage has a unique event number code. Such a code and the corresponding time stamp is called an event.

As an example, a typical event of programmable stage trip event is shown in Table 7.1.

**Table 7.1: Example of Pgr1 stage trip on event and its visibility in local panel and communication protocols**

EVENT	Description	Local panel	Communication protocols
Code: 01E02	Channel 1, event 2	Yes	Yes
Pgr1 trip on	Event text	Yes	No
2.7 x In	Fault value	Yes	No
2007-01-31	Date	Yes	Yes
08:35:13.413	Time	Yes	Yes

Events are the major data for a SCADA system. SCADA systems are reading events using any of the available communication protocols. The Event log can also be scanned using the front panel or Easergy Pro. With Easergy Pro, the events can be stored to a file especially if the relay is not connected to any SCADA system.

Only the latest event can be read when using communication protocols or Easergy Pro. Every reading increments the internal read pointer to the event buffer. (In case of communication interruptions, the latest event can be reread any number of times using another parameter.) On the local panel, scanning the event buffer back and forth is possible.

### Event enabling/masking

An uninteresting event can be masked, which prevents it to be written in the event buffer. By default, there is room for 200 latest events in the buffer. The event buffer size can be modified from 50 to 2000. The existing events are lost if the event buffer size is changed.

You can make this modification in the “Local panel conf” menu.

An indication screen (popup screen) can also be enabled in the same menu in Easergy Pro. The oldest event is overwritten when a new event occurs. The shown resolution of a time stamp is one millisecond, but the actual resolution depends on the particular function creating the event. For example, most protection stages create events with 5 ms, 10 ms or 20 ms resolution. The absolute accuracy of all time stamps depends on the relay's time

synchronization. See Chapter 7.4 System clock and synchronization for system clock synchronizing.

### Event buffer overflow

The normal procedure is to poll events from the relay all the time. If this is not done, the event buffer could reach its limits. In that case, the oldest event is deleted and the newest displayed with OVF (overflow) code on the front panel.

**Table 7.2: Setting parameters for events**

Parameter	Value	Description	Note
Count		Number of events	
ClrEv	- Clear	Clear event buffer	Set
Order	Old-New New-Old	Order of the event buffer for local display	Set
FVScal		Scaling of event fault value	Set
	PU	Per unit scaling	
	Pri	Primary scaling	
Display Alarms	On Off	Indication display is enabled No indication display	Set
Sync		Controls event time format	
	On Off	Event time shown normally if relay is synchronized Event time is shown in brackets if relay is not synchronized	
<b>FORMAT OF EVENTS ON THE LOCAL DISPLAY</b>			
Code: CHENN		CH = event channel, NN=event code (channel number is not shown in case channel is zero)	
Event description		Event channel and code in plain text	
yyyy-mm-dd		Date (for available date formats, see Chapter 7.4 System clock and synchronization)	
hh:mm:ss.nnn		Time	

## 7.2 Disturbance recording

The disturbance recording can be used to record all the measured signals, that is, currents, voltage and the status information of digital inputs (DI) and digital outputs (DO). If the sample rate is slower than 1/10 ms, also the calculated signals like active power, power factor, negative sequence overcurrent and so on can be recorded. For a complete list of signals, see Table 7.3.

The digital inputs also include the arc protection signals.

The available recording channels depend on the voltage measurement mode, too. If a channel is added for recording and the added signal is not available because of the used settings, the signal is automatically rejected from the recording channel list.

### Triggering the recording

The recording can be triggered by any start or trip signal from any protection stage, by a digital input, logic output or GOOSE signals. The triggering signal is selected in the output matrix (vertical signal DR). The recording can also be triggered manually. All recordings are time-stamped.

### Reading recordings

The recordings can be uploaded with Easergy Pro program. The recording is in COMTRADE format. This also means that other programs can be used to view and analyse the recordings made by the relay.

### Number of channels

A maximum of 12 records can be stored. Up to 12 channels per record can be stored. Both the digital inputs and the digital outputs (including all inputs and outputs) use one channel out of the total of 12.

**RECORDER CHANNELS**

	Ch IL1,IL2,IL3,Io1,U12,U23,U31,Uo,DI,DO
Add recorder channel	<input style="width: 100%;" type="text" value="DO"/>
Delete recorder channel	<input style="width: 100%;" type="text" value="-"/>
Remove all channels	<input style="width: 100%;" type="text" value="-"/>

**Table 7.3: Disturbance recording parameters**

Parameter	Value	Unit	Description	Note
Mode			Behavior in memory full situation:	Set
	Saturated		No more recordings are accepted	
	Overflow		The oldest recording is overwritten	
SR			Sample rate	Set
	32/cycle		Waveform	
	16/cycle		Waveform	
	8/cycle		Waveform	
	1/10ms		One cycle value *)	
	1/20ms		One cycle value **)	
	1/200ms		Average	
	1/1s		Average	
	1/5s		Average	
	1/10s		Average	
	1/15s		Average	
	1/30s		Average	
	1/1min		Average	
Time		s	Recording length	Set
PreTrig		%	Amount of recording data before the trig moment	Set
MaxLen		s	Maximum time setting. This value depends on the sample rate, number and type of the selected channels and the configured recording length.	
ReadyRec			Readable recordings	
Status			Status of recording	
	-		Not active	
	Run		Waiting a triggering	
	Trig		Recording	
	FULL		Memory is full in saturated mode	
ManTrig	-, Trig		Manual triggering	Set
ReadyRec	n/m		n = Available recordings / m = maximum number of recordings The value of 'm' depends on the sample rate, number and type of the selected channels and the configured recording length.	

Parameter	Value	Unit	Description	Average	Waveform
AddCh			Add one channel. The maximum number of channels used simultaneously is 12.		
	IL1, IL2, IL3		Phase current	X	X
	Io		Measured earth fault overcurrent	X	X
	U12, U23, U31		Line-to-line voltage	X	X
	UL1, UL2, UL3		Phase-to-neutral voltage	X	X
	Uo		Neutral displacement voltage	X	X
	f		Frequency	X	
	P, Q, S		Active, reactive, apparent power	X	
	P.F.		Power factor	X	
	CosPhi		cosφ	X	
	IoCalc		Phasor sum $I_o = (IL1+IL2+IL3)/3$	X	
	I1		Positive sequence current	X	
	I2		Negative sequence current	X	
	I2/I1		Relative current unbalance	X	
	I2/Imot		Negative sequence overcurrent [ $\times I_{MOT}$ ]	X	
	IL		Average $(IL1 + IL2 + IL3) / 3$	X	
	DI		Digital inputs: DI1–20, F1, F2, BIOin, VI1-4, Arc1, Arc2	X	X
	DI_2		Digital inputs: DI21–40	X	X
	DI_3		Virtual inputs: VI5–20, A1–A5, VO1–VO6	X	X
	DO		Digital outputs: T1–15	X	X
	DO_2		Rest of the outputs	X	X
	DO_3		Virtual outputs, VO7–VO20	X	X
	TanPhi		tanφ	X	
	THDIL1, THDIL2, THDIL3		Total harmonic distortion of IL1, IL2 or IL3	X	
	Prms		Active power rms value	X	
	Qrms		Reactive power rms value	X	
	Srms		Apparent power rms value	X	
	fy		Frequency behind circuit breaker	X	
	fz		Frequency behind 2nd circuit breaker	X	
	IL1RMS, IL2MRS, IL3RMS		IL1, IL2, IL3 RMS for average sampling	X	
	Arc***)		Arc protection signals	X	
	Starts		Protection stage start signals	X	X
	Trips		Protection stage trip signals	X	X
ClrCh	-, Clear		Remove all channels		



Set = An editable parameter (password needed).

\*) This is the fundamental frequency rms value of one cycle updated every 10 ms.

\*\*\*) This is the fundamental frequency rms value of one cycle updated every 20 ms.

\*\*\*) Arc events are polled in every 5 ms.

Signal available depending on the slot 8 options.

**NOTE:** The selection of signals depends on the relay type, the used voltage connection and the scaling mode.

## Characteristics

**Table 7.4: Disturbance recording**

Mode of recording	Saturated / Overflow
Sample rate: - Waveform recording - Trend curve recording	32/cycle, 16/cycle, 8/cycle 10, 20, 200 ms 1, 5, 10, 15, 30 s 1 min
Recording time (one record)	0.1 s–12 000 min (According recorder setting)
Pre-trigger rate	0–100%
Number of selected channels	0–12
File format	IEEE Std C37.111-1999

The recording time and the number of records depend on the time setting and the number of selected channels.

## Configuring the disturbance recorder

The disturbance recorder can be used to record all the measured signals, that is, currents, voltages and the status information of digital inputs (DI) and digital outputs (DO).

For this application example, select the channels and sample rate for the disturbance recorder.

1. go to **General > Disturbance recorder**.
  2. Click the **Add recorder channel** drop-down list and select the channel IL1.
  3. Similarly select the channels IL2, IL3, DO and Arc.
  4. Click the **Sample rate** drop-down list and select the rate 1/20ms.
- To download the disturbance recorder file, select **Tools > Download disturbance records**.

Figure 7.1: Configuring the disturbance recorder for the application example

### Writing the setting to the relay

1. On the Easergy Pro toolbar, select **Write settings > Write all settings** to save the configuration in the relay.

**NOTE:** To save the relay's configuration information for later use, also save the Easergy Pro setting file on the PC.

Use WaveWin or another customer preferred tool to analyze disturbance recorder file.

### Saving the setting file on your PC

1. On the Easergy Pro toolbar, click the **Save** icon. The **Save a file** window opens.
2. Browse to the folder where you want to save the file. Type a descriptive file name, and click **Save**.

**NOTE:** By default, the setting file \*.epz is saved in the eSetup Easergy Pro folder.

## 7.3 Cold load start and magnetising inrush

### Cold load start

A situation is regarded as cold load when all the three phase currents have been below a given idle value and then at least one of the currents exceeds a given start level within 80 ms. In such a case, the cold load detection signal is activated for the time set as **Maximum time** or until the measured signal returns below the value set as **Pickup current**. This signal is available for the output matrix and blocking matrix. Using virtual outputs of the output matrix setting group control is possible.

### Application for cold load detection

Right after closing a circuit breaker, a given amount of overload can be allowed for a given limited time to take care of concurrent thermostat-controlled loads. The cold load start function does this, for example, by selecting a more coarse setting group for overcurrent stages. It is also possible to use the cold load detection signal to block any set of protection stages for a given time.

### Magnetising inrush detection

Magnetising inrush detection is quite similar to the cold load detection but it also includes a condition for second harmonic content of the currents. When all phase currents have been below a given idle value and then at least one of them exceeds a given start level within 80 ms and the second harmonic ratio to fundamental frequency,  $I_{f2}/I_{f1}$ , of at least one phase exceeds the given setting, the inrush detection signal is activated. This signal is available for the output matrix and blocking matrix. Using virtual outputs of the output matrix setting group control is possible.

By setting the second harmonic start parameter for  $I_{f2}/I_{f1}$  to zero, the inrush signal will behave equally with the cold load start signal.

### Application for inrush current detection

The inrush current of transformers usually exceeds the start setting of sensitive overcurrent stages and contains a lot of even harmonics. Right after closing a circuit breaker, the start and tripping of sensitive overcurrent stages can be avoided by selecting a more coarse setting group for the appropriate overcurrent stage with an inrush detect signal. It is also possible to use the detection signal to block any set of protection stages for a given time.

**NOTE:** Inrush detection is based on the fundamental component calculation which requires a full cycle of data for analyzing the harmonic content. Therefore, when using the inrush blocking function, the cold load start starting conditions are used for activating the inrush blocking when the current rise is noticed. If a significant ratio of second harmonic components is found in the signal after the first cycle, the blocking is continued. Otherwise, the second-harmonic-based blocking signal is released. Inrush blocking is recommended to be used on time-delayed overcurrent stages while the non-blocked instant overcurrent stage is set to 20 % higher than the expected inrush current. By this scheme, a fast reaction time in short circuit faults during the energization can be achieved while time-delayed stages are blocked by the inrush function.

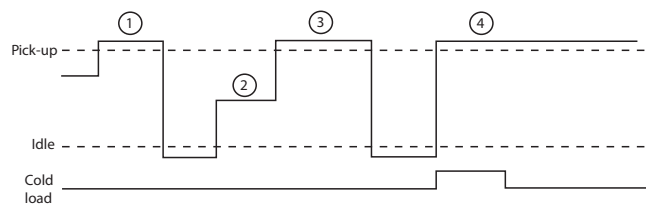

Figure 7.2: Functionality of cold load / inrush current feature.

1. No activation because the current has not been under the set  $I_{DLE}$  current.
2. Current dropped under the  $I_{DLE}$  current level but now it stays between the  $I_{DLE}$  current and the start current for over 80ms.
3. No activation because the phase two lasted longer than 80ms.
4. Now we have a cold load activation which lasts as long as the operate time was set or as long as the current stays above the start setting.

## Characteristics

Table 7.5: Magnetizing inrush detection

Cold load settings:	
- Idle current	0.01 – 0.50 x $I_N$
- Start current	0.30 – 10.00 x $I_N$
- Maximum time	0.01** – 300.00 s (step 0.01 s)
Inrush settings:	
- Start for 2nd harmonic	0 – 99 %

\*\*\*) This is the instantaneous time i.e. the minimum total operational time including the fault detection time and operate time of the trip contacts.

## 7.4 System clock and synchronization

### Description

The relay's internal clock is used to time-stamp events and disturbance recordings.

The system clock should be externally synchronised to get comparable event time stamps for all the relays in the system.

The synchronizing is based on the difference of the internal time and the synchronising message or pulse. This deviation is filtered and the internal time is corrected softly towards a zero deviation.

### Time zone offsets

Time zone offset (or bias) can be provided to adjust the relay's local time. The offset can be set as a Positive (+) or Negative (-) value within a range of -15.00 to +15.00 hours and a resolution of 0.01/h. Basically, resolution by a quarter of an hour is enough.

### Daylight saving time (DST)

The relay provides automatic daylight saving adjustments when configured. A daylight saving time (summer time) adjustment can be configured separately and in addition to a time zone offset.

System Clock	
Date	2017-08-29
Day of week	Tuesday
Time of day	15:04:04
Date style	y-m-d
Time zone	0.00 h
Enable DST	Off
Event enabling	On
Status of DST	
Status of DST	inactive
Next DST changes	
Next DSTbegin date	2018-03-25
DSTbegin hour	03:00
Next DSTend date	2017-10-29
DSTend hour (DST)	04:00

Daylight time standards vary widely throughout the world. Traditional daylight/summer time is configured as one (1) hour positive bias. The new US/Canada DST standard, adopted in the spring of 2007 is one (1) hour positive bias, starting at 2:00am on the second Sunday in March, and ending at 2:00am on the first Sunday in November. In the European Union, daylight change times are defined relative to the UTC time of day instead of local time of day (as in U.S.) European customers, carefully check the local country rules for DST. The daylight saving rules are by default UTC +2:00 (24-hour clock):

- Daylight saving time start: Last Sunday of March at 03.00
- Daylight saving time end: Last Sunday of October at 04.00

The screenshot shows a configuration interface for Daylight Saving Time (DST) rules. It is divided into two sections: 'DSTbegin rule' and 'DSTend rule'.  
 In the 'DSTbegin rule' section, the following settings are visible:  
 - DSTbegin month: Mar (dropdown)  
 - Ordinal of day of week: Last (dropdown)  
 - Day of week: Sunday (dropdown)  
 - DSTbegin hour: 3 (input field)  
 In the 'DSTend rule' section, the following settings are visible:  
 - DSTend month: Oct (dropdown)  
 - Ordinal of day of week: Last (dropdown)  
 - Day of week: Sunday (dropdown)  
 - DSTend hour (DST): 4 (input field) with a 'DST' label to its right.

To ensure proper hands-free year-around operation, automatic daylight time adjustments must be configured using the “Enable DST” and not with the time zone offset option.

### Adapting the auto-adjust function

During tens of hours of synchronizing, the relay learns its average deviation and starts to make small corrections by itself. The target is that when the next synchronizing message is received, the deviation is already near zero. Parameters "AAIntv" and "AvDrft" show the adapted correction time interval of this  $\pm 1$  ms auto-adjust function.

### Time drift correction without external sync

If any external synchronizing source is not available and the system clock has a known steady drift, it is possible to roughly correct the clock deviation by editing the parameters "AAIntv" and "AvDrft". The following equation can be used if the previous "AAIntv" value has been zero.

$$AAIntv = \frac{604.8}{DriftInOneWeek}$$

If the auto-adjust interval "AAIntv" has not been zero, but further trimming is still needed, the following equation can be used to calculate a new auto-adjust interval.

$$AAIntv_{NEW} = \frac{1}{\frac{1}{AAIntv_{PREVIOUS}} + \frac{DriftInOneWeek}{604.8}}$$

The term  $DriftInOneWeek/604.8$  may be replaced with the relative drift multiplied by 1000 if some other period than one week has been used. For example, if the drift has been 37 seconds in 14 days, the relative drift is  $37 \cdot 1000 / (14 \cdot 24 \cdot 3600) = 0.0306$  ms/s.

**Example 1**

If there has been no external sync and the relay's clock is leading sixty-one seconds a week and the parameter *AAIntv* has been zero, the parameters are set as

$$AvDrft = Lead$$

$$AAIntv = \frac{604.8}{61} = 9.9s$$

With these parameter values, the system clock corrects itself with  $-1$  ms every 9.9 seconds which equals  $-61.091$  s/week.

**Example 2**

If there is no external sync and the relay's clock has been lagging five seconds in nine days and the *AAIntv* has been 9.9 s, leading, then the parameters are set as

$$AAIntv_{NEW} = \frac{1}{\frac{1}{9.9} - \frac{5000}{9 \cdot 24 \cdot 3600}} = 10.6$$

$$AvDrft = Lead$$

When the internal time is roughly correct – the deviation is less than four seconds – no synchronizing or auto-adjust turns the clock backwards. Instead, if the clock is leading, it is softly slowed down to maintain causality.

**Table 7.6: System clock parameters**

Parameter	Value	Unit	Description	Note
Date			Current date	Set
Time			Current time	Set
Style			Date format	Set
	y-d-m		Year-Month-Day	
	d.m.y		Day.Month.Year	
	m/d/y		Month/Day/Year	
SyncDI	Possible values depends on the types of I/O cards		The digital input used for clock synchronization.	***)
	-		DI not used for synchronizing	
TZone	-15.00 – +15.00 *)		UTC time zone for SNTP synchronization. Note: This is a decimal number. For example for state of Nepal the time zone 5:45 is given as 5.75	Set
DST	No; Yes		Daylight saving time for SNTP	Set

Parameter	Value	Unit	Description	Note
SySrc			Clock synchronization source	
	Internal		No sync recognized since 200s	
	DI		Digital input	
	SNTP		Protocol sync	
	SpaBus		Protocol sync	
	ModBus		Protocol sync	
	ModBus TCP		Protocol sync	
	ProfibusDP		Protocol sync	
	IEC101		Protocol sync	
	IEC103		Protocol sync	
	DNP3		Protocol sync	
	IRIG-B003		IRIG timecode B003 ****)	
	MsgCnt	0 – 65535, 0 – etc.		The number of received synchronization messages or pulses
Dev	±32767	ms	Latest time deviation between the system clock and the received synchronization	
SyOS	±10000.000	s	synchronization correction for any constant deviation in the synchronizing source	Set
AAIntv	±1000	s	Adapted auto-adjust interval for 1 ms correction	Set**)
AvDrft	Lead; Lag		Adapted average clock drift sign	Set**)
FilDev	±125	ms	Filtered synchronization deviation	

Set = An editable parameter (password needed).

\*) A range of -11 h – +12 h would cover the whole Earth but because the International Date Line does not follow the 180° meridian, a more wide range is needed.

\*\*\*) If external synchronization is used, this parameter is set automatically.

\*\*\*\*) Set the DI delay to its minimum and the polarity such that the leading edge is the synchronizing edge.

\*\*\*\*\*) Relay needs to be equipped with suitable hardware option module to receive IRIG-B clock synchronization signal. (Chapter 13 Order code).

## Synchronization with DI

The clock can be synchronized by reading minute pulses from digital inputs, virtual inputs or virtual outputs. The sync source is selected with the **SySrcDI** setting. When a rising edge is detected from the selected input, the system clock is adjusted to the nearest minute. The length of the digital input pulse should be at least 50 ms. The delay of the selected digital input should be set to zero.



### Synchronization correction

If the sync source has a known offset delay, it can be compensated with the **SyOS** setting. This is useful for compensating hardware delays or transfer delays of communication protocols. A positive value compensates a lagging external sync and communication delays. A negative value compensates any leading offset of the external sync source.

### Sync source

When the relay receives new sync message, the sync source display is updated. If no new sync messages are received within the next 1.5 minutes, the relay switches over to internal sync mode.

### Sync source: IRIG-B

IRIG standard time formats B003 and B004 are supported with a dedicated communication option (See Chapter 13 Order code). IRIG-B input clock signal voltage level is TLL. The input clock signal originated in the GPS receiver must be taken to multiple relays through an IRIG-B distribution module. This module acts as a centralized unit for a point-to-multiple point connection.

**NOTE:** Daisy chain connection of IRIG-B signal inputs in multiple relays must be avoided.

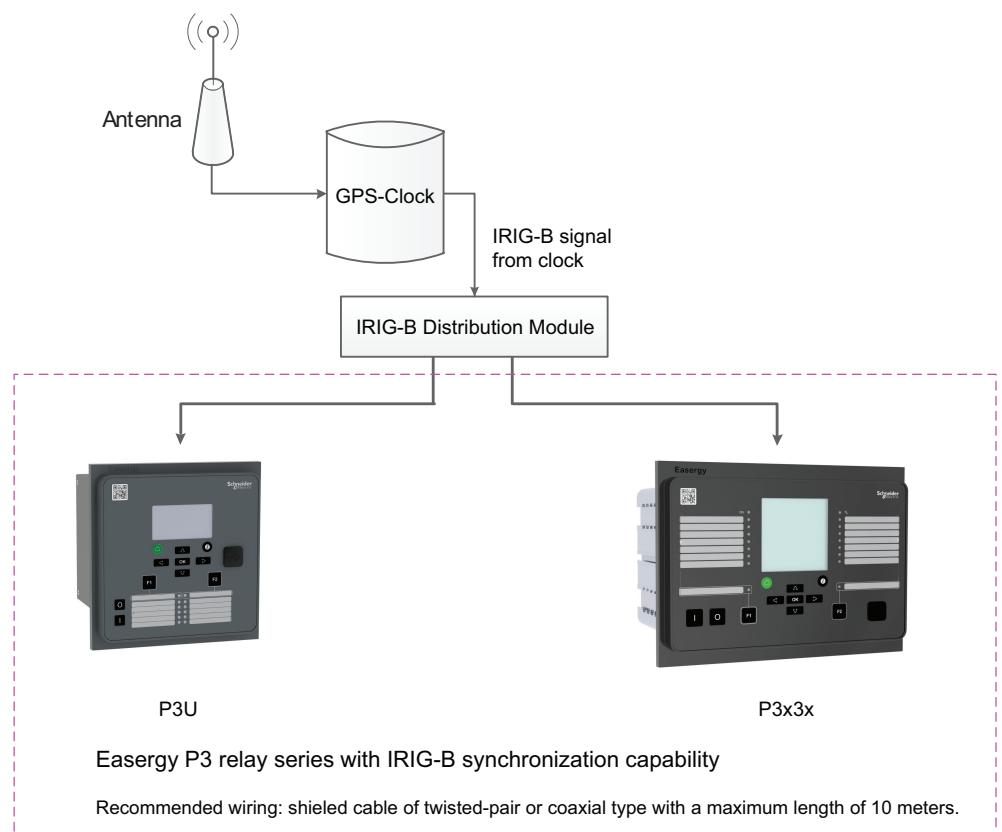

The recommended cable must be shielded and either of coaxial or twisted pair type. Its length must not exceed 10 meters.

**Deviation**

The time deviation means how much the system clock time differs from the sync source time. The time deviation is calculated after receiving a new sync message. The filtered deviation means how much the system clock was really adjusted. Filtering takes care of small deviation in sync messages.

**Auto-lag/lead**

The relay synchronizes to the sync source, meaning that it starts automatically leading or lagging to stay in perfect sync with the master. The learning process takes a few days.

## 7.5 Voltage sags and swells

### Description

The power quality of electrical networks has become increasingly important. Sophisticated loads (for example computers) require an uninterruptible supply of “clean” electricity. The Easergy P3 protection platform provides many power quality functions that can be used to evaluate and monitor the quality and alarm on the basis of the quality. One of the most important power quality functions is voltage sag and swell monitoring.

Easergy P3 provides separate monitoring logs for sags and swells. The voltage log is triggered if any voltage input either goes under the sag limit ( $U<$ ) or exceeds the swell limit ( $U>$ ). There are four registers for both sags and swells in the fault log. Each register contains start time, phase information, duration and the minimum, average and maximum voltage values of each sag and swell event. Furthermore, it contains the total number of sags and swells counters as well as the total number of timers for sags and swells.

The voltage power quality functions are located under the submenu “U”.

**Table 7.7: Setting parameters of sags and swells monitoring**

Parameter	Value	Unit	Default	Description
U>	20 – 150	%	110	Setting value of swell limit
U<	10 – 120	%	90	Setting value of sag limit
Delay	0.04 – 1.00	s	0.06	Delay for sag and swell detection
SagOn	On; Off	-	On	Sag on event
SagOff	On; Off	-	On	Sag off event
SwelOn	On; Off	-	On	Swell on event
SwelOf	On; Off	-	On	Swell off event

**Table 7.8: Recorded values of sags and swells monitoring**

	Parameter	Value	Unit	Description
Recorded values	Count		-	Cumulative sag counter
	Total		-	Cumulative sag time counter
	Count		-	Cumulative swell counter
	Total		-	Cumulative swell time counter
Sag / swell logs 1 – 4	Date		-	Date of the sag/swell
	Time		-	Time stamp of the sag/swell
	Type		-	Voltage inputs that had the sag/swell
	Time		s	Duration of the sag/swell
	Min1		% Un	Minimum voltage value during the sag/swell in the input 1
	Min2		% Un	Minimum voltage value during the sag/swell in the input 2
	Min3		% Un	Minimum voltage value during the sag/swell in the input 3
	Ave1		% Un	Average voltage value during the sag/swell in the input 1
	Ave2		% Un	Average voltage value during the sag/swell in the input 2
	Ave3		% Un	Average voltage value during the sag/swell in the input 3
	Max1		% Un	Maximum voltage value during the sag/swell in the input 1
	Max2		% Un	Maximum voltage value during the sag/swell in the input 2
	Max3		% Un	Maximum voltage value during the sag/swell in the input 3

## Characteristics

**Table 7.9: Voltage sag & swell**

Voltage sag limit	10 – 120 %U <sub>N</sub> (step 1%)
Voltage swell limit	20 – 150 %U <sub>N</sub> (step 1%)
Definite time function: - Operate time	DT 0.08 – 1.00 s (step 0.02 s)
Low voltage blocking	0 – 50 %
Reset time	< 60 ms
Reset ration: - Sag - Swell	>1.03 <0.97
Block limit	0.5 V or 1.03 (3 %)
Inaccuracy: - Activation - Activation (block limit) - Operate time at definite time function	±0.5 V or 3% of the set value ±5% of the set value ±1% or ±30 ms

If one of the line-to-line voltages is below sag limit and above block limit but another line-to-line voltage drops below block limit, blocking is disabled.

## 7.6 Voltage interruptions

### Description

The relay includes a simple function to detect voltage interruptions. The function calculates the number of voltage interruptions and the total time of the voltage-off time within a given calendar period. The period is based on the relay's real-time clock. The available periods are:

- 8 hours, 00:00 – 08:00, 08:00 – 16:00, 16:00 – 24:00
- one day, 00:00 – 24:00
- one week, Monday 00:00 – Sunday 24:00
- one month, the first day 00:00 – the last day 24:00
- one year, 1st January 00:00 – 31st December 24:00

After each period, the number of interruptions and the total interruption time are stored as previous values. The interruption counter and the total time are cleared for a new period. Previous values are overwritten.

Voltage interruption is based on the value of the positive sequence voltage  $U_1$  and a limit value you can define. Whenever the measured  $U_1$  goes below the limit, the interruption counter is increased, and the total time counter starts increasing.

The shortest recognized interruption time is 40 ms. If the voltage-off time is shorter, it may be recognized depending on the relative depth of the voltage dip.

If the voltage has been significantly over the limit  $U_1 <$  and then there is a small and short under-swing, it is not recognized (Figure 7.3).

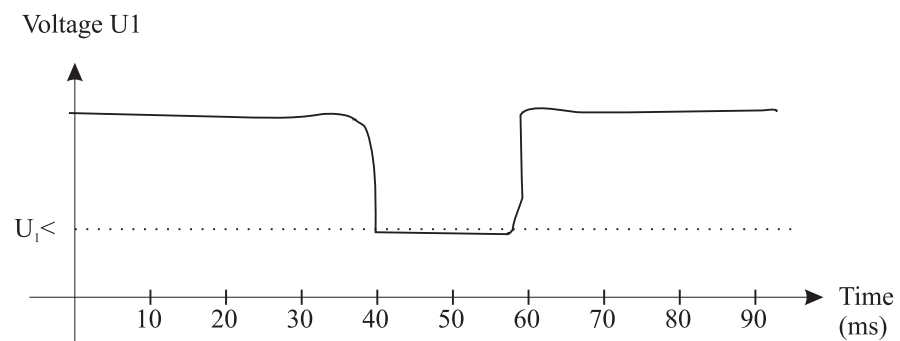

Figure 7.3: A short voltage interruption which is probably not recognized

On the other hand, if the limit  $U_1 <$  is high and the voltage has been near this limit, and then there is a short but very deep dip, it is not recognized (Figure 7.4).

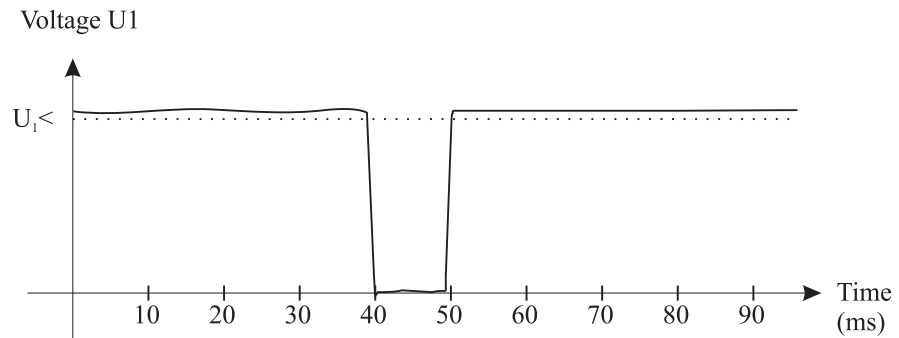

Figure 7.4: A short voltage interrupt that will be recognized

**Table 7.10: Setting parameters of the voltage sag measurement function**

Parameter	Value	Unit	Default	Description
U1<	10.0 – 120.0	%	64	Setting value
Period	8h Day Week Month	-	Month	Length of the observation period
Date		-	-	Date
Time		-	-	Time

**Table 7.11: Measured and recorded values of voltage sag measurement function**

	Parameter	Value	Unit	Description
Measured value	Voltage	LOW; OK	-	Current voltage status
	U1		%	Measured positive sequence voltage
Recorded values	Count		-	Number of voltage sags during the current observation period
	Prev		-	Number of voltage sags during the previous observation period
	Total		s	Total (summed) time of voltage sags during the current observation period
	Prev		s	Total (summed) time of voltage sags during the previous observation period

## Characteristics

**Table 7.12: Voltage interruptions**

Voltage low limit ( $U_1$ )	10 – 120 % $U_N$ (step 1%)
Definite time function: - Operate time	DT <60 ms (Fixed)
Reset time	< 60 ms
Reset ratio	>1.03
Inaccuracy: - Activation	3% of the set value

## 7.7 Current transformer supervision (ANSI 60)

### Description

The relay supervises the current transformers (CTs) and the external wiring between the relay terminals and the CTs. This is a safety function as well, since an open secondary of a CT causes dangerous voltages.

The CT supervision function measures phase currents. If one of the three phase currents drops below the  $I_{MIN}<$  setting while another phase current exceeds the  $I_{MAX}>$  setting, the function issues an alarm after the operation delay has elapsed.

**Table 7.13: Setting parameters of CT supervision**

Parameter	Value	Unit	Default	Description
$I_{max}>$	0.0 – 10.0	xIn	2.0	Upper setting for CT supervision current scaled to primary value, calculated by relay
$I_{min}<$	0.0 – 10.0	xIn	0.2	Lower setting for CT supervision current scaled to primary value, calculated by relay
$t>$	0.02 – 600.0	s	0.10	Operation delay
CT on	On; Off	-	On	CT supervision on event
CT off	On; Off	-	On	CT supervision off event

**Table 7.14: Measured and recorded values of CT**

	Parameter	Value	Unit	Description
Measured value	ILmax		A	Maximum of phase currents
	ILmin		A	Minimum of phase currents
Display	$I_{max}>$ , $I_{min}<$		A	Setting values as primary values
Recorded values	Date		-	Date of CT supervision alarm
	Time		-	Time of CT supervision alarm
	I <sub>max</sub>		A	Maximum phase current
	I <sub>min</sub>		A	Minimum phase current



## Characteristics

**Table 7.15: Current transformer supervision**

$I_{MAX}>$ setting	0.00 – 10.00 x $I_N$ (step 0.01)
$I_{MIN}<$ setting	0.00 – 10.00 x $I_N$ (step 0.01)
Definite time function: - Operate time	DT 0.04 – 600.00 s (step 0.02 s)
Reset time	< 60 ms
Reset ratio $I_{MAX}>$	0.97
Reset ratio $I_{MIN}<$	1.03
Inaccuracy: - Activation - Operate time at definite time function	$\pm 3\%$ of the set value $\pm 1\%$ or $\pm 30$ ms

## 7.8 Voltage transformer supervision (ANSI 60FL)

### Description

The relay supervises the voltage transformers (VTs) and VT wiring between the relay terminals and the VTs. If there is a fuse in the voltage transformer circuitry, the blown fuse prevents or distorts the voltage measurement. Therefore, an alarm should be issued. Furthermore, in some applications, protection functions using voltage signals should be blocked to avoid false tripping.

The VT supervision function measures three line-to-line voltages and currents. The negative sequence voltage  $U_2$  and the negative sequence current  $I_2$  are calculated. If  $U_2$  exceed the  $U_{2>}$  setting and at the same time,  $I_2$  is less than the  $I_{2<}$  setting, the function issues an alarm after the operation delay has elapsed.

**Table 7.16: Setting parameters of VT supervision**

Parameter	Value	Unit	Default	Description
$U_{2>}$	0.0 – 200.0	% $U_N$	34.6	Upper setting for VT supervision
$I_{2<}$	0.0 – 200.0	% $I_N$	100.0	Lower setting for VT supervision
$t>$	0.02 – 600.0	s	0.10	Operation delay
VT on	On; Off	-	On	VT supervision on event
VT off	On; Off	-	On	VT supervision off event

**Table 7.17: Measured and recorded values of VT supervision**

	Parameter	Value	Unit	Description
Measured value	$U_2$		% $U_N$	Measured negative sequence voltage
	$I_2$		% $I_N$	Measured negative sequence current
Recorded Values	Date		-	Date of VT supervision alarm
	Time		-	Time of VT supervision alarm
	$U_2$		% $U_N$	Recorded negative sequence voltage
	$I_2$		% $I_N$	Recorded negative sequence current

## Characteristics

**Table 7.18: Voltage transformer supervision**

U <sub>2</sub> > setting	0.0 – 200.0 % (step 0.1%)
I <sub>2</sub> < setting	0.0 – 200.0 % (step 0.1%)
Definite time function: - Operate time	DT 0.04 – 600.00 (step 0.02s)
Reset time	< 60 ms
Reset ratio	3% of the start value
Inaccuracy: - Activation U <sub>2</sub> > - Activation I <sub>2</sub> < - Operate time at definite time function	±1%-unit ±1%-unit ±1% or ±30 ms

## 7.9 Circuit breaker condition monitoring

### Description

**NOTE:** In the device's user interface, this function is called CB wear.

The relay has a condition monitoring function that supervises circuit breaker (CB) wear. The condition monitoring can provide an alarm about the need of CB maintenance well before the CB condition is critical.

The CB condition monitoring measures the breaking current of each CB pole separately and then estimates CB wear according to the permissible cycle diagram. The breaking current is registered when the trip relay supervised by the circuit breaker failure protection (CBFP) is activated. (See Chapter 6.13 Breaker failure 1 (ANSI 50BF) for CBFP and the setting parameter "CBrelay" through front panel and "Monitored Trip relay" using Easergy Pro.)

### Circuit breaker curve and its approximation

The permissible cycle diagram is usually available in the documentation of the CB manufacturer (Figure 7.5). The diagram specifies the permissible number of cycles for every level of the breaking current. This diagram is parameterised to the condition monitoring function with a maximum of eight [current, cycles] points. See Table 7.19. If fewer than eight points are needed, the unused points are set to  $[I_{BIG}, 1]$ , where  $I_{BIG}$  is more than the maximum breaking capacity.

If the CB wear characteristics or a part of them is a straight line on a log/log graph, the two end points are enough to define that part of the characteristics. This is because the relay is using logarithmic interpolation for any current values falling in between the given current points 2-8.

The points 4-8 are not needed for the CB in Figure 7.5. Thus, they are set to 100 kA and one operation in the table is discarded by the algorithm.

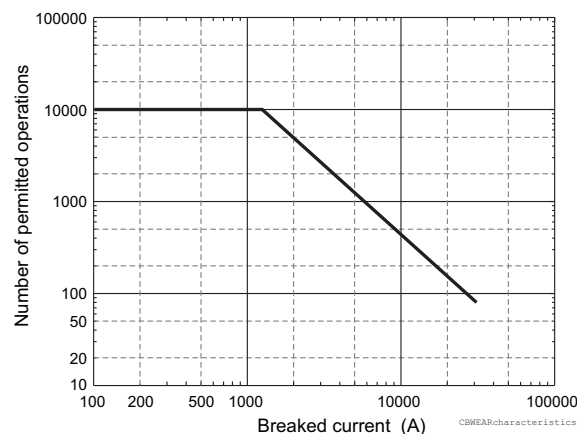

Figure 7.5: An example of a circuit breaker wear characteristic graph.

**Table 7.19: An example of circuit breaker wear characteristics.**

Point	Interrupted current (kA)	Number of permitted operations
1	0 (mechanical age)	10000
2	1.25 (rated current)	10000
3	31.0 (maximum breaking current)	80
4	100	1
5	100	1
6	100	1
7	100	1
8	100	1

The values are taken from the figure above. The table is edited with Easergy Pro under menu "BREAKER CURVE".

### Setting alarm points

There are two alarm points available having two setting parameters each.

- **Current**  
The first alarm can be set for example to the CB's nominal current or any application-typical current. The second alarm can be set for example according to a typical fault current.
- **"Operations left" alarm limit**  
An alarm is activated when there are less operations left at the given current level than this limit.

Any actual interrupted current is logarithmically weighted for the two given alarm current levels and the number of operations left at the alarm points is decreased accordingly. When the number of remaining operations goes under the given alarm limit, an alarm signal is issued to the output matrix. Also, an event is generated depending on the event enabling.

### Clearing "operations left" counters

After the CB curve table is filled and the alarm currents are defined, the wearing function can be initialised by clearing the decreasing operation counters with the parameter "Clear" (Clear oper. left cntrs). After clearing, the relay shows the maximum allowed operations for the defined alarm current levels.

### Operation counters to monitor the wearing

The operations left can be read from the counters "AI1Ln" (Alarm 1) and "AI2Ln" (Alarm2). There are three values for both alarms, one for each phase. The smallest value is supervised by the two alarm functions.

### Logarithmic interpolation

The permitted number of operations for the currents in between the defined points is logarithmically interpolated using equation Equation 7.1.

Equation 7.1:

$$C = \frac{a}{I^n}$$

C = permitted operations

I = interrupted current

a = constant according Equation 7.2

n = constant according Equation 7.3

Equation 7.2:

Equation 7.3:

$$n = \frac{\ln \frac{C_k}{C_{k+1}}}{\ln \frac{I_{k+1}}{I_k}}$$

$$a = C_k I_k^2$$

ln = natural logarithm function

$C_k, C_{k+1}$  = permitted operations. k = row 2 – 7 in Table 7.19.

$I_k, I_{k+1}$  = corresponding current. k = row 2 – 7 in Table 7.19.

### Example of the logarithmic interpolation

Alarm 2 current is set to 6 kA. The maximum number of operations is calculated as follows.

The current 6 kA lies between points 2 and 3 in the table. That gives value for the index k. Using

k = 2

$C_k = 10000$

$C_{k+1} = 80$

$I_{k+1} = 31 \text{ kA}$

$I_k = 1.25 \text{ kA}$

and the Equation 7.2 and Equation 7.3, the relay calculates

$$n = \frac{\ln \frac{10000}{80}}{\ln \frac{31000}{1250}} = 1.5038$$

$$a = 10000 \cdot 1250^{1.5038} = 454 \cdot 10^6$$

Using Equation 7.1 the relay gets the number of permitted operations for current 6 kA.

$$C = \frac{454 \cdot 10^6}{6000^{1.5038}} = 945$$

Thus, the maximum number of current-breaking operations at 6 kA is 945. This can be verified with the original CB curve in Figure 7.5. Indeed, the figure shows that at 6 kA, the operation count is between 900 and 1000. A useful alarm level for operations left could be in this case for example 50 which is about five percent of the maximum.

### Example of operation counter decrementing when the CB is breaking a current

Alarm2 is set to 6 kA. The CB failure protection is supervising trip relay T1, and a trip signal of an overcurrent stage detecting a two-phase fault is connected to this trip relay T1. The interrupted phase currents are 12.5 kA, 12.5 kA and 1.5 kA. By what number are Alarm2 counters decremented?

Using Equation 7.1 and values  $n$  and  $a$  from the previous example, the relay gets the number of permitted operations at 10 kA.

$$C_{10kA} = \frac{454 \cdot 10^6}{12500^{1.5038}} = 313$$

At alarm level 2, 6 kA, the corresponding number of operations is calculated according to Equation 7.4.

Equation 7.4:

$$\Delta = \frac{C_{AlarmMax}}{C}$$

$$\Delta_{L1} = \Delta_{L2} = \frac{945}{313} = 3$$

Thus, Alarm2 counters for phases L1 and L2 are decremented by 3. In phase L1, the current is less than the alarm limit current 6 kA. For such currents, the decrement is one.

$$\Delta_{L3} = 1$$

**Table 7.20: Local panel parameters of CBWEAR function**

Parameter	Value	Unit	Description	Set
<b>CBWEAR STATUS</b>				
AI1L1			Operations left for - Alarm 1, phase L1	
AI1L2			- Alarm 1, phase L2	
AI1L3			- Alarm 1, phase L3	
AI2L1			- Alarm 2, phase L1	
AI2L2			- Alarm 2, phase L2	
AI2L3			- Alarm 2, phase L3	
<b>Latest trip</b>				
Date time			Time stamp of the latest trip operation	
IL1		A	Broken current of phase L1	
IL2		A	Broken current of phase L2	
IL3		A	Broken current of phase L3	
<b>CBWEAR SET</b>				
Alarm1				
Current	0.00 – 100.00	kA	Alarm1 current level	Set
Cycles	100000 – 1		Alarm1 limit for operations left	Set
Alarm2				
Current	0.00 – 100.00	kA	Alarm2 current level	Set
Cycles	100000 – 1		Alarm2 limit for operations left	Set
<b>CBWEAR SET2</b>				
AI1On	On ; Off		'Alarm1 on' event enabling	Set
AI1Off	On ; Off		'Alarm1 off' event enabling	Set
AI2On	On ; Off		'Alarm2 on' event enabling	Set
AI2Off	On ; Off		'Alarm2 off' event enabling	Set
Clear	-; Clear		Clearing of cycle counters	Set

Set = An editable parameter (password needed).

The CB curve table is edited with Easergy Pro.



## 7.10 Circuit breaker condition monitoring 1 and 2

**NOTE:** In the device's user interface, this function is called CB wear 1 and 2. Stages 1 and 2 are identical and allow monitoring two circuit breakers simultaneously.

### Description

The relay has five measurement functions that collect the following types of data to enable circuit breaker (CB) condition monitoring:

- number of operations
- cumulative breaking current
- operate times (CB opening and closing times)
- charging time
- number of racking out operations

### Number of operations

The purpose of this counter is to record the number of CB operation cycles. The counter is incremented by one each time the CB changes its position from closed to open and from open to closed. The counter is incremented independently of the origin of the operation that can be for example:

- protection relay
- mechanical push buttons on CB front
- external wired command
- control unit

To implement this counter, use the two auxiliary contacts' switching which give the CB position to increment the counter.

There is also a sub-counter that counts the operations that are triggered by a protection function.

The counters have the following access types:

- read: access via MODBUS serial or TCP protocol
- write: it is possible to overwrite this data from a parametrization tool with special access rights

### Cumulative breaking current

Each time the CB opens, the breaking current is added to the cumulative total and to the appropriate range of the cumulative breaking current.

The cumulative breaking current is given in  $(kA)^2$ .

In addition to the total cumulative breaking current, there are five cumulative breaking current ranges to assess the breaking device pole condition:

- 0-2  $I_n$
- 2-5  $I_n$
- 5-10  $I_n$
- 10-40  $I_n$
- > 40  $I_n$

The cumulative breaking current is also computed by phase.

When the relay is in test mode or the CB has been withdrawn, the cumulative breaking current is not updated.

The cumulative counters have the following access types:

- read: access via MODBUS serial or TCP protocol
- write: it is possible to overwrite this data from a parametrization tool with special access rights

### Operate times

The CB opening time is measured from the switching of the auxiliary contacts from the closed position to the open position.

The CB closing time is measured from the switching of the auxiliary contacts from the open position to the closed position.

The protection relay records the last 10 opening times and the last 10 closing times, each being time-stamped and independent of the origin of the operation (for example the relay itself or a mechanical push button).

These values only have read access via MODBUS serial or TCP protocol.

### Charging time

The protection relay records the last 10 spring charging time operations, each being time-stamped.

These values only have read access via MODBUS serial or TCP protocol.

The charging time is computed from the switch of the CB position (from open to closed) and the change of the state of the auxiliary contact indicating the spring charged status (from discharged to charged).

## Number of racking out operations

The purpose of this counter is to record the number of rack in/out operations. The counter is incremented by one each time the CB changes its position from inserted to withdrawn and from withdrawn to inserted. A cycle (in/out, out/in) counts for one operation. This counter is incremented independently of the origin of the operation that can be for example:

- mechanically from front of the switchgear
- external wired command
- control unit

This counter has the following access types:

- read: access via MODBUS serial or TCP protocol
- write: it is possible to overwrite this data from a parametrization tool with special access rights

The counter is computed from the change state of the rack in/out contacts (in some cases, there is a single contact, and in some cases, there are two contacts).

## Characteristics

**Table 7.21: Characteristics**

Function	Allowed range	Accuracy	Resolution	Access type from the network interface	Stored in non-volatile memory	Data format
Number of operations	0-65535	1	1	R/W	Y	UI32bit
Cumulative breaking current	0-2 <sup>32</sup> -1kA <sup>2</sup>	+/- 10 %	1kA <sup>2</sup>	R/W	Y	UI32bit
Operate times	0-300 ms	+/- 1 ms	1 ms	R	Y	UI16bit
Charging time	0-1 min	+/- 1 s	500 ms	R	N	UI16bit
Number of racking out operations	0-65535	1	1	R/W	Y	UI32bit

Set the value that is returned when a measured value is out of the allowed range to a “dummy” value. This allows you to easily detect if something is wrong.

## 7.11 Energy pulse outputs

### Description

The relay can be configured to send a pulse whenever a certain amount of energy has been imported or exported. The principle is presented in Figure 7.6. Each time the energy level reaches the pulse size, a digital output is activated and the relay is active as long as defined by a pulse duration setting.

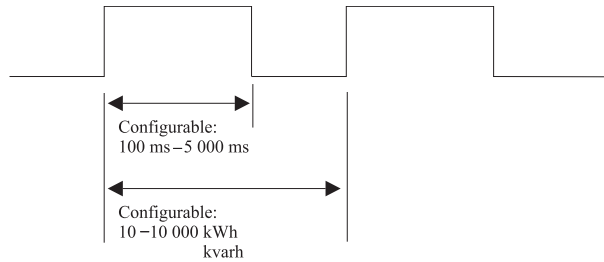

Figure 7.6: Principle of energy pulses

The relay has four energy pulse outputs. The output channels are:

- active exported energy
- reactive exported energy
- active imported energy
- reactive imported energy

Each channel can be connected to any combination of the digital outputs using the output matrix. The parameters for the energy pulses can be found in the ENERGY menu "E" under the submenus E-PULSE SIZES and E-PULSE DURATION.

Table 7.22: Energy pulse output parameters

	Parameter	Value	Unit	Description
E-PULSE SIZES	E+	10 – 10 000	kWh	Pulse size of active exported energy
	Eq+	10 – 10 000	kvarh	Pulse size of reactive exported energy
	E-	10 – 10 000	kWh	Pulse size of active imported energy
	Eq-	10 – 10 000	kvarh	Pulse size of reactive imported energy
E-PULSE DURATION	E+	100 – 5000	ms	Pulse length of active exported energy
	Eq+	100 – 5000	ms	Pulse length of reactive exported energy
	E-	100 – 5000	ms	Pulse length of active imported energy
	Eq-	100 – 5000	ms	Pulse length of reactive imported energy

### Scaling examples

1. The average active exported power is 250 MW.  
The peak active exported power is 400 MW.  
The pulse size is 250 kWh.  
The average pulse frequency is  $250/0.250 = 1000$  pulses/h.  
The peak pulse frequency is  $400/0.250 = 1600$  pulses/h.  
Set pulse length to  $3600/1600 - 0.2 = 2.0$  s or less.  
The lifetime of the mechanical digital output is  $50 \times 10^6 / 1000$  h = 6 a.  
This is not a practical scaling example unless a digital output lifetime of about six years is accepted.
2. The average active exported power is 100 MW.  
The peak active exported power is 800 MW.  
The pulse size is 400 kWh.  
The average pulse frequency is  $100/0.400 = 250$  pulses/h.  
The peak pulse frequency is  $800/0.400 = 2000$  pulses/h.  
Set pulse length to  $3600/2000 - 0.2 = 1.6$  s or less.  
The lifetime of the mechanical digital output is  $50 \times 10^6 / 250$  h = 23 a.
3. Average active exported power is 20 MW.  
Peak active exported power is 70 MW.  
Pulse size is 60 kWh.  
The average pulse frequency is  $25/0.060 = 416.7$  pulses/h.  
The peak pulse frequency is  $70/0.060 = 1166.7$  pulses/h.  
Set pulse length to  $3600/1167 - 0.2 = 2.8$  s or less.  
The lifetime of the mechanical digital output is  $50 \times 10^6 / 417$  h = 14 a.
4. Average active exported power is 1900 kW.  
Peak active exported power is 50 MW.  
Pulse size is 10 kWh.  
The average pulse frequency is  $1900/10 = 190$  pulses/h.  
The peak pulse frequency is  $50000/10 = 5000$  pulses/h.  
Set pulse length to  $3600/5000 - 0.2 = 0.5$  s or less.  
The lifetime of the mechanical digital output is  $50 \times 10^6 / 190$  h = 30 a.

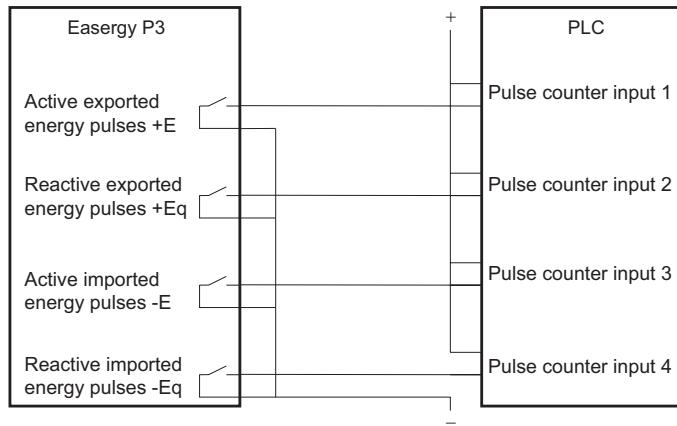

Figure 7.7: Application example of wiring the energy pulse outputs to a PLC having common plus and using an external wetting voltage

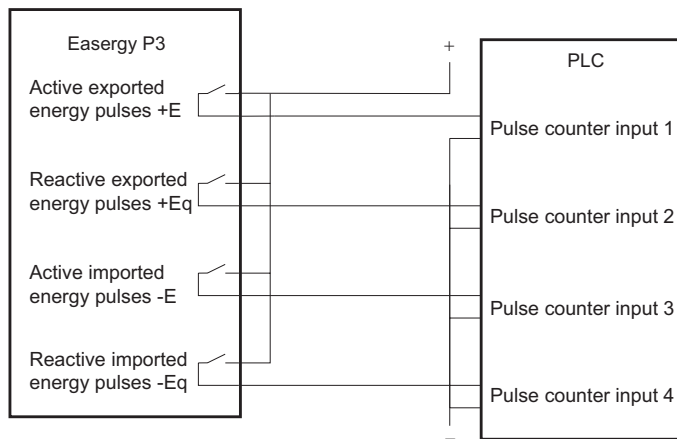

Figure 7.8: Application example of wiring the energy pulse outputs to a PLC having common minus and using an external wetting voltage

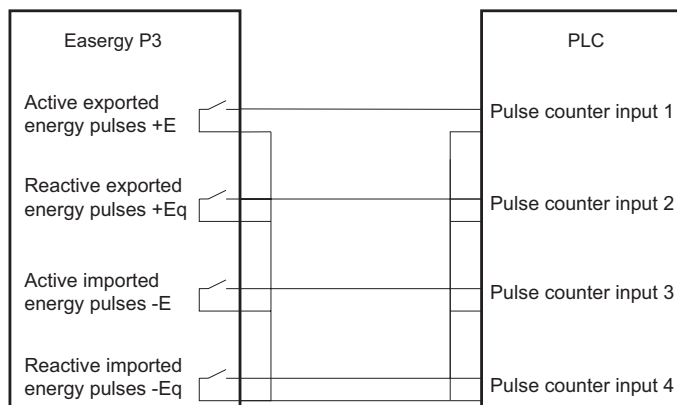

Figure 7.9: Application example of wiring the energy pulse outputs to a PLC having common minus and an internal wetting voltage.

## 7.12 Running hour counter

### Description

The running hour counter is typically used to monitor the service time of the motor or appropriate feeder. This function calculates the total active time of the selected digital input, virtual I/O function button, GOOSE signal, POC signal or output matrix output signal. The resolution is ten seconds.

**Table 7.23: Running hour counter parameters**

Parameter	Value	Unit	Description	Note
Runh	0 – 876000	h	Total active time, hours Note: The label text "Runh" can be edited with Easergy Pro.	(Set)
Runs	0 – 3599	s	Total active time, seconds	(Set)
Starts	0 – 65535		Activation counter	(Set)
Status	Stop Run		Current status of the selected digital signal	
Started at			Date and time of the last activation	
Stopped at			Date and time of the last inactivation	

Set = An editable parameter (password needed).

(Set) = An informative value which can be edited as well.

## 7.13 Timers

### Description

The Easergy P3 protection platform includes four settable timers that can be used together with the user's programmable logic or to control setting groups and other applications that require actions based on calendar time. Each timer has its own settings. The selected on-time and off-time is set, after which the activation of the timer can be set to be as daily or according to the day of the week (See the setting parameters for details). The timer outputs are available for logic functions and for the block and output matrix.

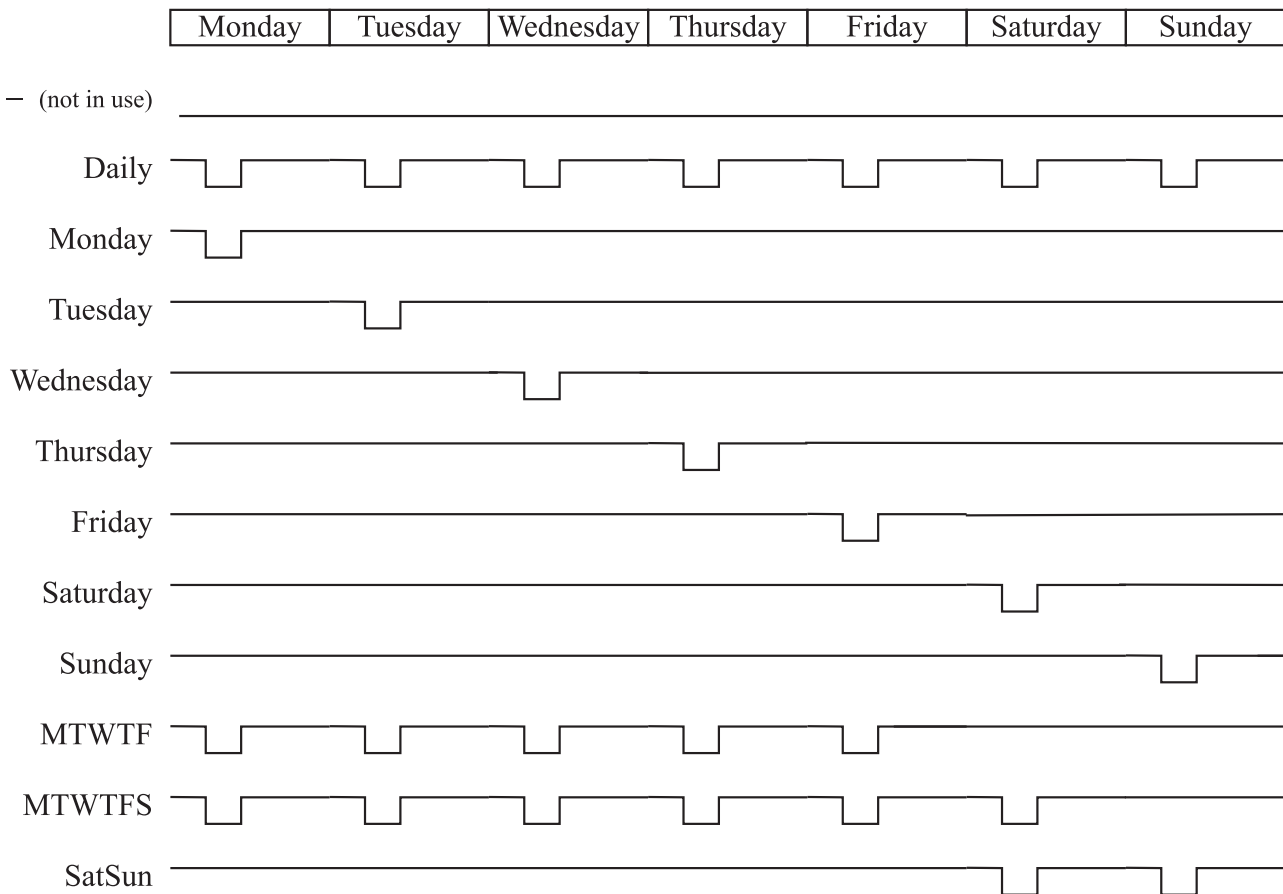

Figure 7.10: Timer output sequence in different modes

You can force any timer, which is in use, on or off. The forcing is done by writing a new status value. No forcing flag is needed as in forcing for example the digital outputs.

The forced time is valid until the next forcing or until the next reversing timed act from the timer itself.

The status of each timer is stored in the non-volatile memory when the auxiliary power is switched off. At startup, the status of each timer is recovered.



**Table 7.24: Setting parameters of timers**

Parameter	Value	Description
TimerN	- 0 1	Timer status Not in use Output is inactive Output is active
On	hh:mm:ss	Activation time of the timer
Off	hh:mm:ss	De-activation time of the timer
Mode		For each four timers there are 12 different modes available:
	-	The timer is off and not running. The output is off i.e. 0 all the time.
	Daily	The timer switches on and off once every day.
	Monday	The timer switches on and off every Monday.
	Tuesday	The timer switches on and off every Tuesday.
	Wednesday	The timer switches on and off every Wednesday.
	Thursday	The timer switches on and off every Thursday.
	Friday	The timer switches on and off every Friday.
	Saturday	The timer switches on and off every Saturday.
	Sunday	The timer switches on and off every Sunday.
	MTWTF	The timer switches on and off every day except Saturdays and Sundays
	MTWTFS	The timer switches on and off every day except Sundays.
	SatSun	The timer switches on and off every Saturday and Sunday.

## 7.14 Combined overcurrent status

### Description

This function collects faults, fault types and registered fault currents of all enabled overcurrent stages and shows them in the event log.

The combined overcurrent status can be used as an indication of faults. Combined o/c indicates the amplitude of the last occurred fault. Also, a separate indication of the fault type is informed during the start and the trip. Active phases during the start and the trip are also activated in the output matrix. After the fault is switched off, the active signals release after the set delay “clearing delay“ has passed. The combined o/c status refers to the following over current stages:  $I_{>}$ ,  $I_{>>}$ ,  $I_{>>>}$ ,  $I_{\phi>}$ ,  $I_{\phi>>}$ ,  $I_{\phi>>>}$  and  $I_{\phi>>>>}$ .

**Table 7.25: Line fault parameters**

Parameter	Value	Unit	Description	Note
IFitLas		$\times I_{MOT}$	Current of the latest overcurrent fault	(Set)
<b>LINE ALARM</b>				
AlrL1 AlrL2 AlrL3	0 1		Start (=alarm) status for each phase. 0 = No start since alarm ClrDly 1 = Start is on	
OCs	0 1		Combined overcurrent start status. AlrL1 = AlrL2 = AlrL3 = 0 AlrL1 = 1 or AlrL2 = 1 or AlrL3 = 1	
LxAlarm	On Off		'On' Event enabling for AlrL1 – 3 Events are enabled Events are disabled	Set
LxAlarmOff	On Off		'Off' Event enabling for AlrL1...3 Events are enabled Events are disabled	Set
OCAAlarm	On Off		'On' Event enabling for combined o/c starts Events are enabled Events are disabled	Set
OCAAlarmOff	On Off		'Off' Event enabling for combined o/c starts Events are enabled Events are disabled	Set
IncFitEvt	On Off		Disabling several start <u>and</u> trip events of the same fault Several events are enabled *) Several events of an increasing fault is disabled **)	Set
ClrDly	0 – 65535	s	Duration for active alarm status AlrL1, AlrL2, AlrL3 and OCs	Set

Parameter	Value	Unit	Description	Note
<b>LINE FAULT</b>				
FltL1			Fault (=trip) status for each phase.	
FltL2	0		0 = No fault since fault ClrDly	
FltL3	1		1 = Fault is on	
OCT	0 1		Combined overcurrent trip status. FltL1 = FltL2 = FltL3 = 0 FltL1 = 1 or FltL2 = 1 or FltL3 = 1	
LxTrip	On Off		'On' Event enabling for FltL1 – 3 Events are enabled Events are disabled	Set
LxTripOff	On Off		'Off' Event enabling for FltL1...3 Events are enabled Events are disabled	Set
OCTrip	On Off		'On' Event enabling for combined o/c trips Events are enabled Events are disabled	Set
OCTripOff	On Off		'Off' Event enabling for combined o/c starts Events are enabled Events are disabled	Set
IncFltEvt	On Off		Disabling several events of the same fault Several events are enabled *) Several events of an increasing fault is disabled **)	Set
ClrDly	0 – 65535		Duration for active alarm status FltL1, FltL2, FltL3 and OCT	Set

Set = An editable parameter (password needed).

\*) Used with IEC 60870-105-103 communication protocol. The alarm screen shows the latest fault current if it is the biggest registered fault current, too. Not used with Spabus because Spabus masters usually do not like to have unpaired On/Off events.

\*\*) Used with SPA-bus protocol because most SPA-bus masters need an off-event for each corresponding on-event.

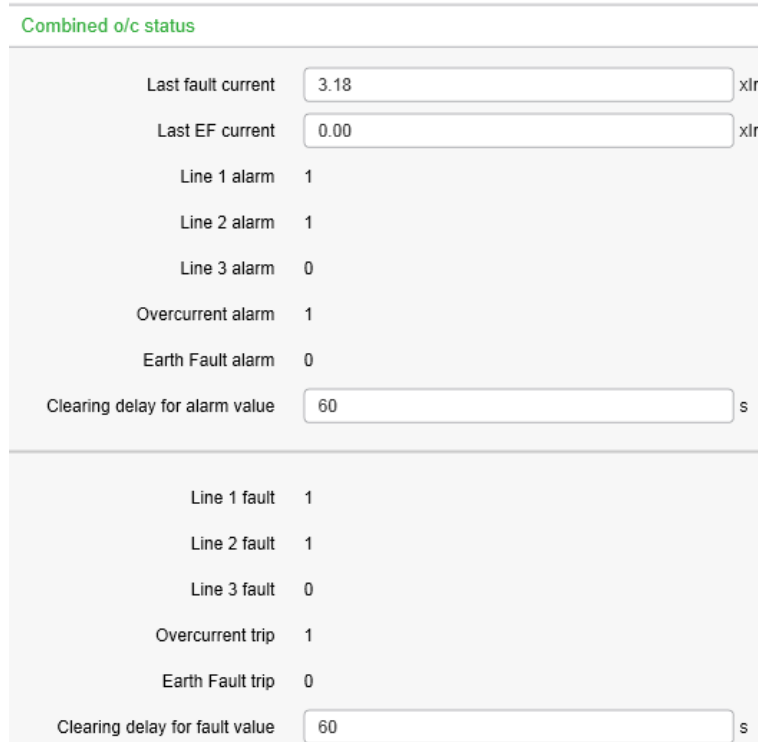

Figure 7.11: Combined o/c status

The fault that can be seen in the Figure 7.11 was 3.18 times to nominal and it increased in to a two phase short circuit L1-L2. All signals those are stated as “1” are also activated in the output matrix. After the fault disappears, the activated signals release.

The combined overcurrent status can be found from Easergy Pro through **Protection > Protection stage status 2**.

## 7.15 Trip circuit supervision (ANSI 74)

### Description

Trip circuit supervision is used to ensure that the wiring from the protective relay to a circuit breaker (CB) is in order. Even though the trip circuit is unused most of the time, keeping it in order is important so that the CB can be tripped whenever the relay detects a fault in the network.

The digital inputs of the relay can be used for trip circuit monitoring. Also the closing circuit can be supervised using the same principle.

**NOTE:** Apply trip circuit supervision using a digital input and its programmable time delay.

### 7.15.1 Trip circuit supervision with one digital input

The benefits of this scheme are that only one digital inputs is needed and no extra wiring from the relay to the circuit breaker (CB) is needed. Also, supervising a 24 Vdc trip circuit is possible.

The drawback is that an external resistor is needed to supervise the trip circuit on both CB positions. If supervising during the closed position only is enough, the resistor is not needed.

- The digital input is connected parallel to the trip contacts (Figure 7.12).
- The digital input is configured as normal closed (NC).
- The digital input delay is configured to be longer than the maximum fault time to inhibit any superfluous trip circuit fault alarm when the trip contact is closed.
- The digital input is connected to a relay in the output matrix giving out any trip circuit alarm.
- The trip relay must be configured as non-latched. Otherwise, a superfluous trip circuit fault alarm follows after the trip contact operates, and the relay remains closed because of latching.
- By utilizing an auxiliary contact of the CB for the external resistor, also the auxiliary contact in the trip circuit can be supervised.

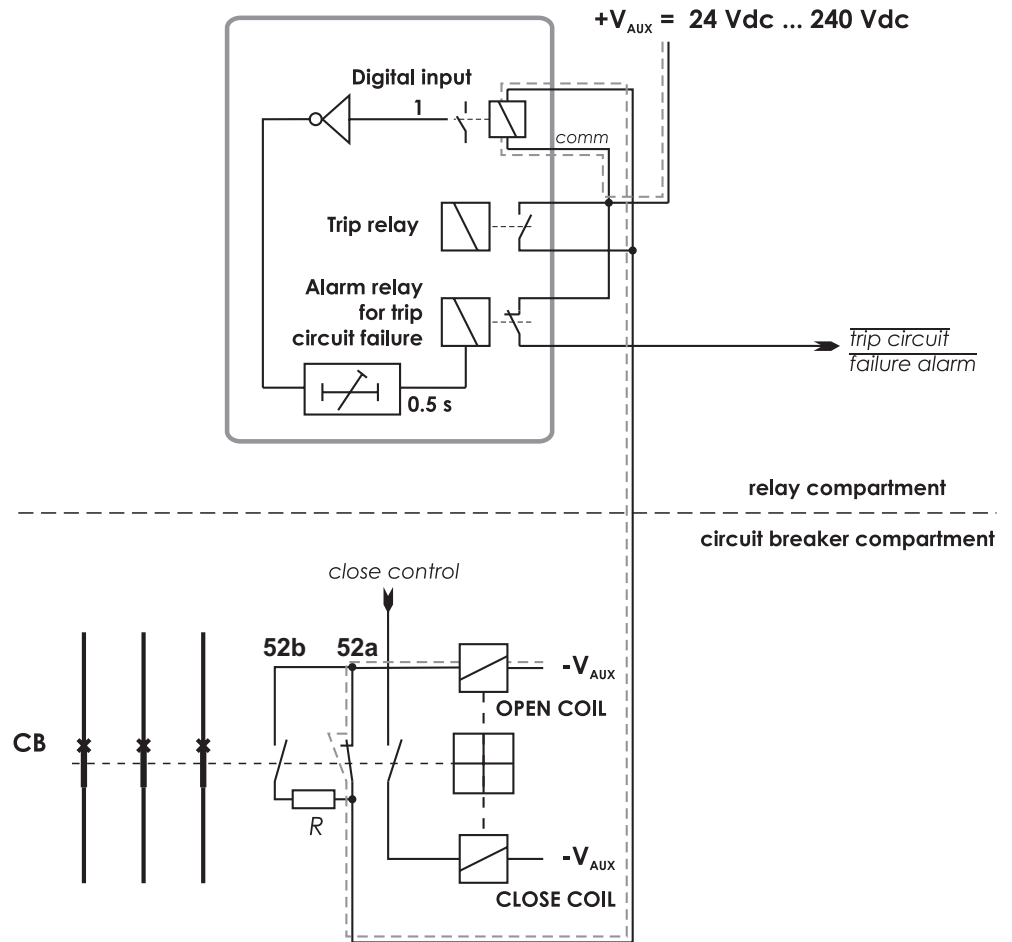

Figure 7.12: Trip circuit supervision using a single digital input and an external resistor R.

The circuit-breaker is in the closed position. The supervised circuitry in this CB position is double-lined. The digital input is in active state when the trip circuit is complete.

This is applicable for any digital inputs.

**NOTE:** The need for the external resistor R depends on the application and circuit breaker manufacturer's specifications.

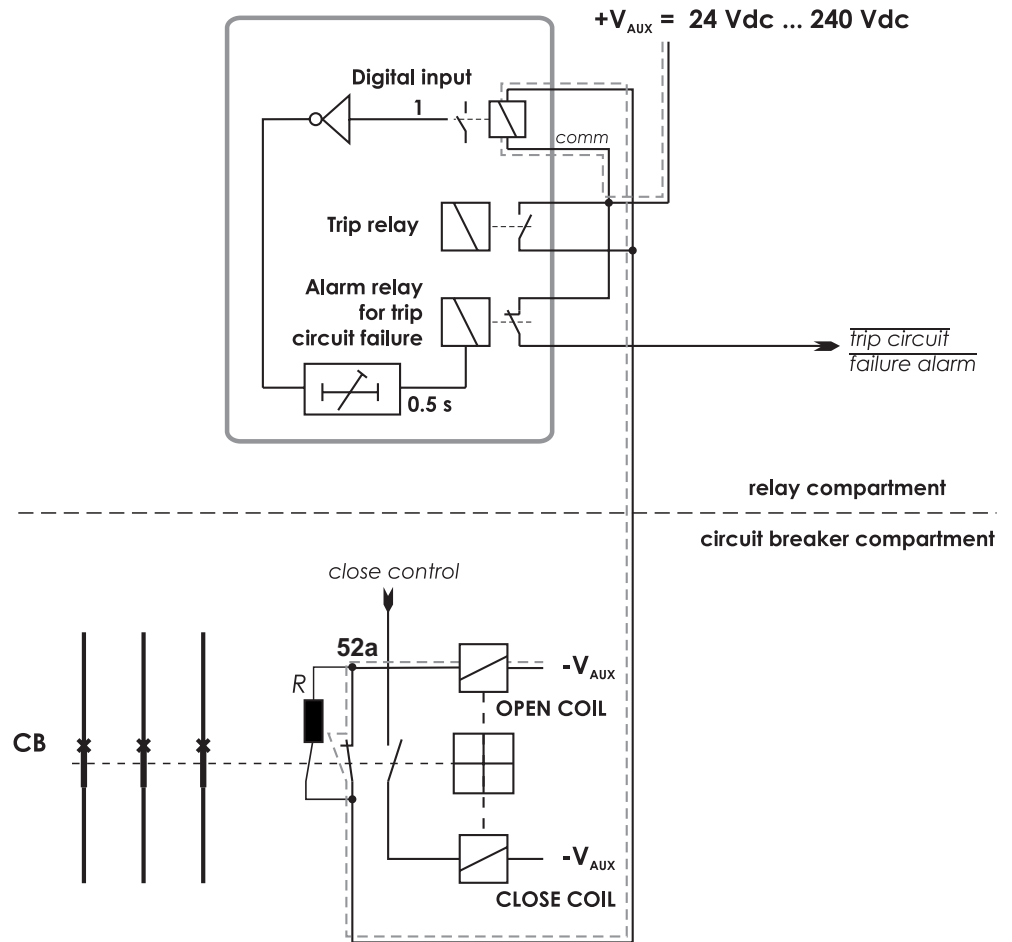

Figure 7.13: Alternative connection without using circuit breaker 52b auxiliary contacts.

Trip circuit supervision using a single digital input and an external resistor R. The circuit breaker is in the closed position. The supervised circuitry in this CB position is double-lined. The digital input is in active state when the trip circuit is complete.

Alternative connection without using circuit breaker 52b auxiliary contacts. This is applicable for any digital inputs.

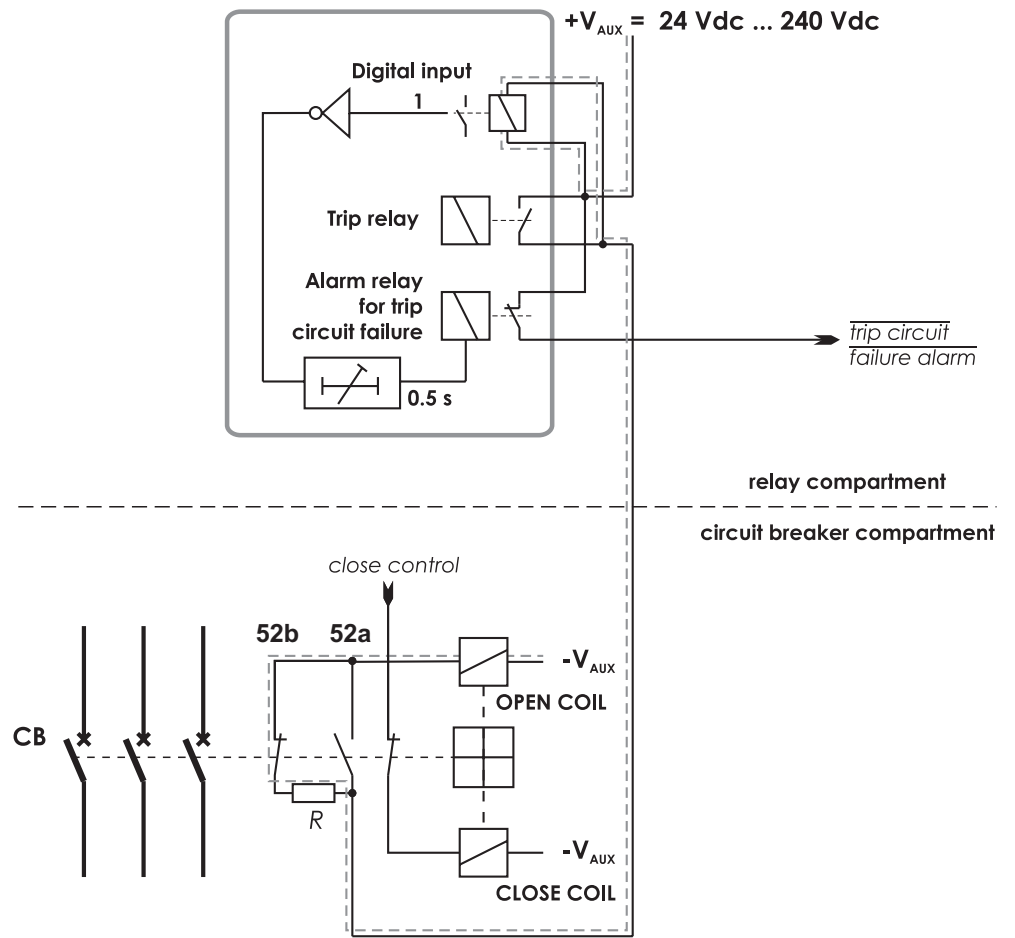

Figure 7.14: Trip circuit supervision using a single digital input when the circuit breaker is in open position.



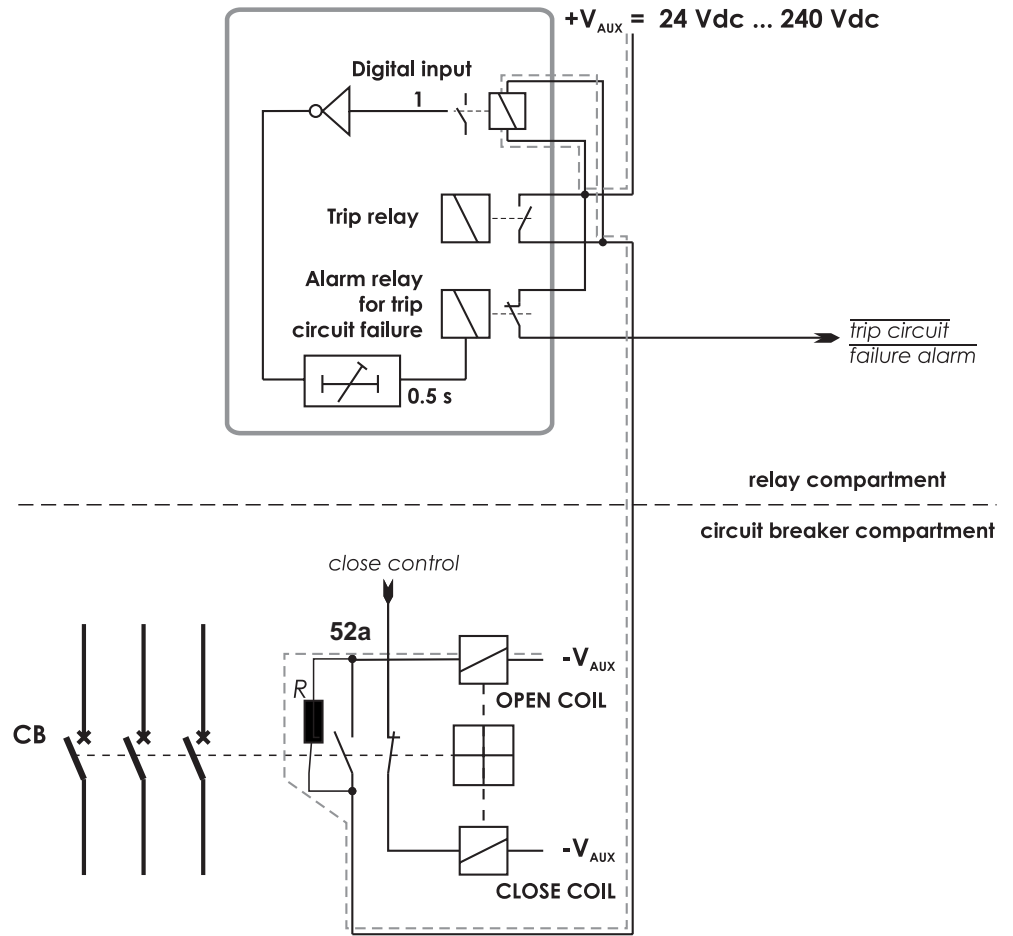

Figure 7.15: Alternative connection without using circuit breaker 52b auxiliary contacts. Trip circuit supervision using a single digital input, when the circuit breaker is in open position.

DIGITAL INPUTS

-	Input	State	Polarity	Delay	On Event	Off Event	Alarm display	Counters
On	1	0	NO	0.00	On	On	On	0
On	2	0	NO	0.00	On	On	On	0
On	3	0	NO	0.00	On	On	On	3
On	4	0	NO	0.00	On	On	On	0
On	5	0	NO	0.00	On	On	On	0
On	6	0	NO	0.00	On	On	On	0
On	7	0	NC	0.50	Off	Off	Off	1

Figure 7.16: An example of digital input DI7 configuration for trip circuit supervision with one digital input.

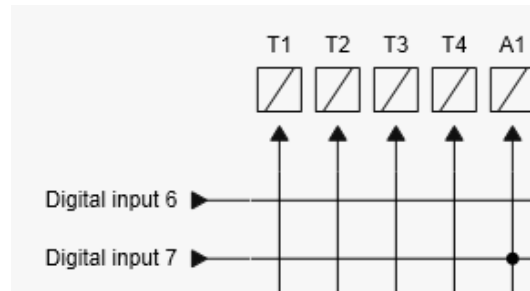

Figure 7.17: An example of output matrix configuration for trip circuit supervision with one digital input.

### Example of dimensioning the external resistor R

$U_{AUX} =$  110 Vdc - 20 % + 10%, Auxiliary voltage with tolerance

$U_{DI} =$  18 Vdc, Threshold voltage of the digital input

$I_{DI} =$  3 mA, Typical current needed to activate the digital input including a 1 mA safety margin.

$P_{COIL} =$  50 W, Rated power of the open coil of the circuit breaker. If this value is not known, 0  $\Omega$  can be used for the  $R_{COIL}$ .

$U_{MIN} =$   $U_{AUX} - 20 \% = 88$  V

$U_{MAX} =$   $U_{AUX} + 10 \% = 121$  V

$R_{COIL} =$   $U_{AUX}^2 / P_{COIL} = 242$   $\Omega$ .

The external resistance value is calculated using Equation 7.5.

Equation 7.5:

$$R = \frac{U_{MIN} - U_{DI} - I_{DI} \cdot R_{Coil}}{I_{DI}}$$

$$R = (88 - 18 - 0.003 \times 242) / 0.003 = 23.1 \text{ k}\Omega$$

(In practice, the coil resistance has no effect.)

By selecting the next smaller standard size, we get **22 k $\Omega$** .

The power rating for the external resistor is estimated using Equation 7.6 and Equation 7.7. The Equation 7.6 is for the CB open situation including a 100 % safety margin to limit the maximum temperature of the resistor.

Equation 7.6:

$$P = 2 \cdot I_{DI}^2 \cdot R$$

$$P = 2 \times 0.003^2 \times 22000 = 0.40 \text{ W}$$

Select the next bigger standard size, for example **0.5 W**.

When the trip contacts are still closed and the CB is already open, the resistor has to withstand much higher power (Equation 7.7) for this short time.

*Equation 7.7:*

$$P = \frac{U_{MAX}^2}{R}$$

$$P = 121^2 / 22000 = 0.67 \text{ W}$$

A 0.5 W resistor is enough for this short time peak power, too. However, if the trip relay is closed for longer than a few seconds, a 1 W resistor should be used.

## 7.15.2 Trip circuit supervision with two digital inputs

The benefit of this scheme is that no external resistor is needed. The drawbacks are that two digital inputs and two extra wires from the relay to the CB compartment are needed. Additionally, the minimum allowed auxiliary voltage is 48 V dc which is more than twice the threshold voltage of the digital input because when the CB is in open position, the two digital inputs are in series.

- The first digital input is connected parallel to the auxiliary contact of the circuit breaker's open coil.
- Another auxiliary contact is connected in series with the circuitry of the first digital input. This makes it possible to supervise also the auxiliary contact in the trip circuit.
- The second digital input is connected in parallel with the trip contacts.
- Both inputs are configured as normal closed (NC).
- The user's programmable logic is used to combine the digital input signals with an AND port. The delay is configured to be longer than the maximum fault time to inhibit any superfluous trip circuit fault alarm when the trip contact is closed.
- The output from the logic is connected to a relay in the output matrix giving out any trip circuit alarm.

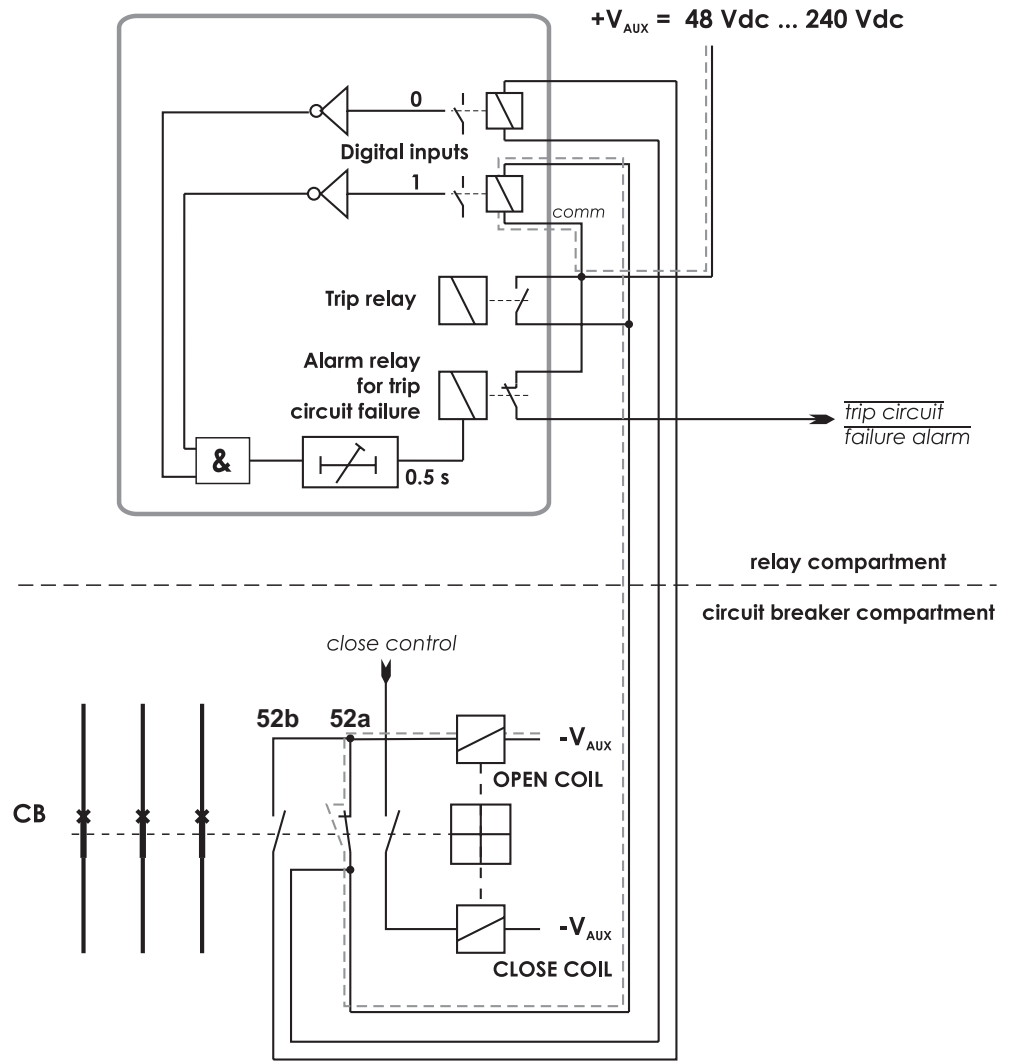

Figure 7.18: Trip circuit supervision with two digital inputs. The CB is closed. The supervised circuitry in this CB position is double-lined. The digital input is in active state when the trip circuit is complete. This is applicable for all digital inputs.

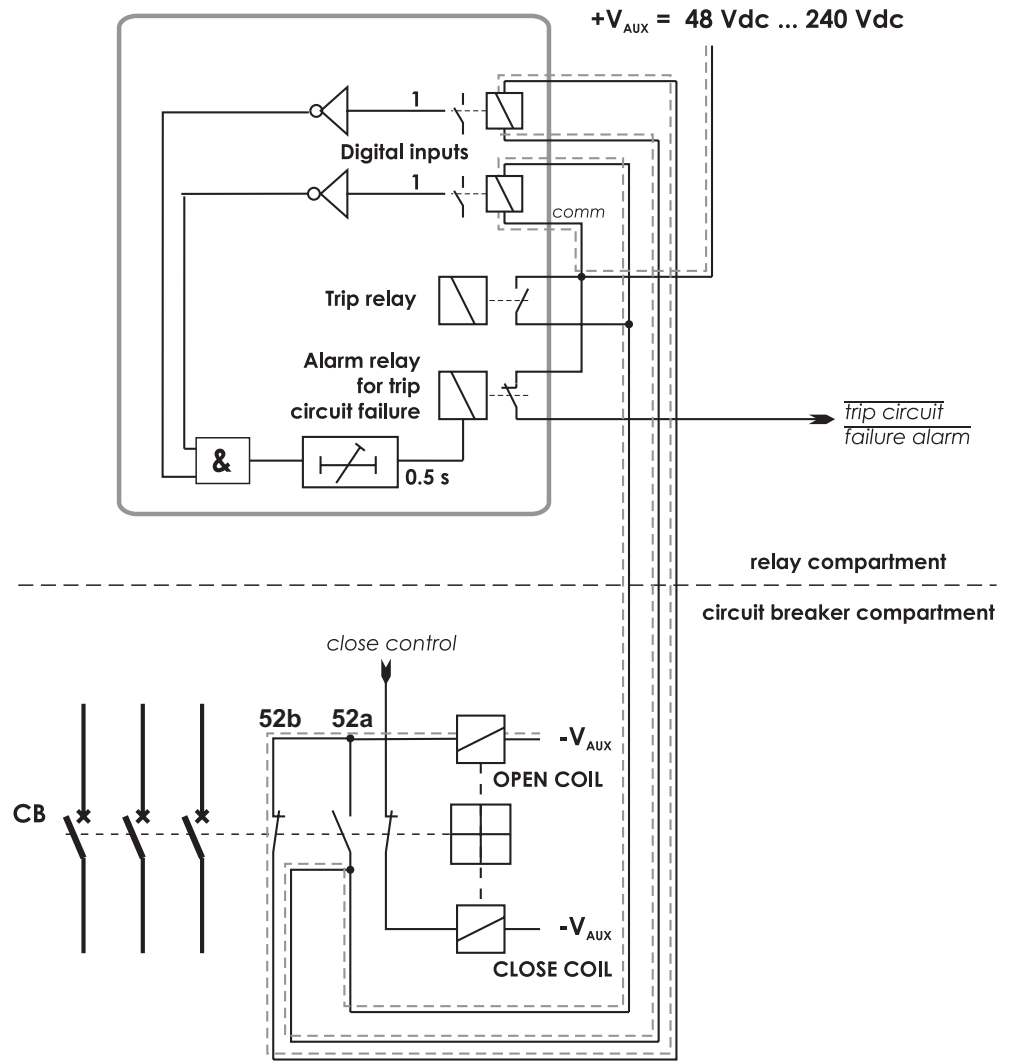

Figure 7.19: Trip circuit supervision with two digital inputs. The CB is in the open position. The two digital inputs are now in series.

DIGITAL INPUTS

Mode DC

Counters max value 16 bit

DIGITAL INPUTS

Input	Slot	State	Polarity	Delay	On Event	Off Event	Alarm display	Counters
1	2	1	NC	0.00	<input type="checkbox"/>	<input type="checkbox"/>	<input type="checkbox"/>	1
2	2	1	NC	0.00	<input type="checkbox"/>	<input type="checkbox"/>	<input type="checkbox"/>	1
3	2	0	NO	0.00	<input checked="" type="checkbox"/>	<input checked="" type="checkbox"/>	<input checked="" type="checkbox"/>	1
4	2	0	NO	0.00	<input checked="" type="checkbox"/>	<input checked="" type="checkbox"/>	<input checked="" type="checkbox"/>	1

Figure 7.20: An example of digital input configuration for trip circuit supervision with two digital inputs DI1 and DI2.

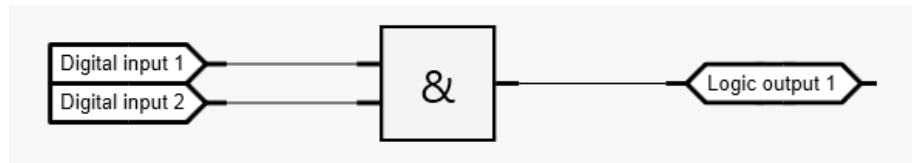

Figure 7.21: An example of logic configuration for trip circuit supervision with two digital inputs DI1 and DI2.

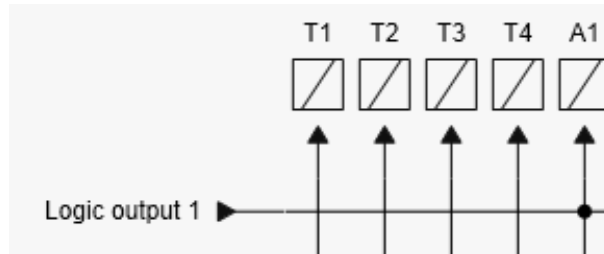

Figure 7.22: An example of output matrix configuration for trip circuit supervision with two digital inputs.

# 8 Communication and protocols

## 8.1 Communication ports

The relay has one fixed communication port: A USB port on the front panel for connection to Easergy Pro setting and configuration tool. Optionally, the relay may have up to 2 serial ports COM 3 and COM 4 for serial protocols (for example IEC 103) and one Ethernet port for Ethernet-based communication protocols (for example IEC 61850).

The number of available serial ports depends on the type of the communication option cards.



COM 1 and COM 2 ports

ETHERNET

**NOTE:** It is possible to have up to 2 serial communication protocols simultaneously in the same D9 and Ethernet connector but restriction is that same protocol can be used only once.

Protocol configuration menu contains selection for the protocol, port settings and message/error/timeout counters.

COM 1 PORT	
Enable communication port	<input checked="" type="checkbox"/> <span style="float: right;">🔌</span>
COM 1 port protocol	IEC-103 <span style="float: right;">🔌</span>
	- 9600/8N1
Message counter	0 <span style="float: right;">Clear</span>
Error counter	0 <span style="float: right;">Clear</span>
Timeout counter	0 <span style="float: right;">Clear</span>
COM 2 PORT	
Enable communication port	<input checked="" type="checkbox"/> <span style="float: right;">🔌</span>
COM 2 port protocol	ProfibusDP <span style="float: right;">🔌</span>
	- 9600/8N1
Message counter	0 <span style="float: right;">Clear</span>
Error counter	0 <span style="float: right;">Clear</span>
Timeout counter	0 <span style="float: right;">Clear</span>

Figure 8.1: Protocols can be enabled in the “protocol configuration” menu. Only serial communication protocols are valid with RS-232 interface.

**Table 8.1: Parameters**

Parameter	Value	Unit	Description	Note
Protocol			Protocol selection for COM port	Set
	None		-	
	SPA-bus		SPA-bus (slave)	
	ProfibusDP		Interface to Profibus DB module VPA 3CG (slave)	
	ModbusSlv		Modbus RTU slave	
	IEC-103		IEC-60870-5-103 (slave)	
	ExternalIO		Modbus RTU master for external I/O-modules	
	IEC 101		IEC-608670-5-101	
	DNP3		DNP 3.0	
	DeviceNet		Interface to DeviceNet module VSE 009	
	GetSet		Communicationi protocols for Easergy Pro interface	
Msg#	0 – $2^{32} - 1$		Message counter since the relay has restarted or since last clearing	Clr
Errors	0 – $2^{16} - 1$		Protocol interruption since the re- lay has restarted or since last clearing	Clr
Tout	0 – $2^{16} - 1$		Timeout interruption since the re- lay has restarted or since last clearing	Clr
	speed/DPS		Display of current communication parameters. speed = bit/s D = number of data bits P = parity: none, even, odd S = number of stop bits	1.

Set = An editable parameter (password needed)

Clr = Clearing to zero is possible

1. The communication parameters are set in the protocol specific menus. For the local port command line interface the parameters are set in configuration menu.



## 8.1.1 Ethernet port

The Ethernet port is used for Ethernet protocols like IEC61850 and Modbus TCP.

The physical interface is described in Chapter 10.5 Connections.

The parameters for the port can be set via the relay's front panel or using Easergy Pro. Two different protocols can be used simultaneously - both protocols use the same IP address and MAC address (but different port number).

ETHERNET PORT	
Enable communication port	<input checked="" type="checkbox"/>
MAC address	001AD3011561
Enable DHCP service	<input type="checkbox"/>
Enable IP verification service	<input type="checkbox"/>
IP Address	10.4.128.92
NetMask	255.255.240.0
Gateway ARP max tryouts	5
Gateway	10.4.128.254
NTP server	10.4.128.250
NTP server (BackUp)	0.0.0.0
IP port for setting tool	23
TCP keepalive interval	0 s
Ethernet packets received	0
Ethernet packets sent	0
Eth Port1 status	Link down
Eth Port2 status	Link down

Ethernet Protocol 1	
Enable communication port	<input checked="" type="checkbox"/>
Ethernet port protocol	None
IP port for protocol 1	502
Set protocol default IP port	-
Message counter	0
Error counter	0
Timeout counter	0

Ethernet Protocol 2	
Enable communication port	<input checked="" type="checkbox"/>
Ethernet port protocol 2nd inst	None
IP port for protocol 2	502
Set protocol default IP port	-
Message counter	0
Error counter	0
Timeout counter	0

REDUNDANCY PROTOCOL FOR ETHERNET	
Redundancy Protocol	PRP

Figure 8.2: Setting view for serial and Ethernet protocols

## 8.2 Communication protocols

The protocols enable the transfer of the following type of data:

- events
- status information
- measurements
- control commands
- clock synchronization
- some settings through SPA bus and IEC-103 protocols

### 8.2.1 Modbus RTU and Modbus TCP

Modbus RTU and Modbus TCP protocols are often used in power plants and industrial applications. The difference between these two protocols is the media. Modbus TCP uses Ethernet and Modbus RTU uses RS-485, optic fibre, or RS-232.

Easergy Pro shows a list of all available data items for Modbus. They are also available as a zip file ("Communication parameter protocol mappings.zip").

The Modbus communication is activated via a menu selection with the parameter "Protocol". See Chapter 8.1 Communication ports.

For more information on Modbus configuration, see the document *P3APS18025EN Modbus configuration instructions for P3 relays*.

For the Ethernet interface configuration, see Chapter 8.1.1 Ethernet port.

### 8.2.2 Profibus DP

The Profibus DP protocol is widely used in the industry. An external VPA 3CG and VX072 cables are required.

#### Device profile "continuous mode"

In this mode, the relay is sending a configured set of data parameters continuously to the Profibus DP master. The benefit of this mode is the speed and easy access to the data in the Profibus master. The drawback is the maximum buffer size of 128 bytes, which limits the number of data items transferred to the master. Some PLCs have their own limitation for the Profibus buffer size, which may further limit the number of transferred data items.

#### Device profile "Request mode"

Using the request mode, it is possible to read all the available data from the Easergy P3 relay and still use only a very short buffer for

---

Profibus data transfer. The drawback is the slower overall speed of the data transfer and the need of increased data processing at the Profibus master as every data item must be separately requested by the master.

**NOTE:** In the request mode, it is not possible to read continuously only one single data item. At least two different data items must be read in turn to get updated data from the relay.

There is a separate manual for VPA 3CG for the continuous mode and request mode. The manual is available for downloading on our website.

#### **Available data**

Easergy Pro shows the list of all available data items for both modes. A separate document "Communication parameter protocol mappings.zip" is also available.

The Profibus DP communication is activated usually for remote port via a menu selection with parameter "Protocol". See Chapter 8.1 Communication ports.

### **8.2.3**

#### **SPA-bus**

The relay has full support for the SPA-bus protocol including reading and writing the setting values. Also, reading multiple consecutive status data bits, measurement values or setting values with one message is supported.

Several simultaneous instances of this protocol, using different physical ports, are possible, but the events can be read by one single instance only.

There is a separate document "Communication parameter protocol mappings.zip" of SPA-bus data items available.

## 8.2.4 IEC 60870-5-103 (IEC-103)

The IEC standard 60870-5-103 "*Companion standard for the informative interface of protection equipment*" provides a standardized communication interface to a primary system (master system).

The unbalanced transmission mode of the protocol is used, and the relay functions as a secondary station (slave) in the communication. Data is transferred to the primary system using the "data acquisition by polling" principle.

### **The IEC functionality includes application functions:**

- station initialization
- general interrogation
- clock synchronization
- command transmission.

It is not possible to transfer parameter data or disturbance recordings via the IEC 103 protocol interface.

### **The following application service data unit (ASDU) types can be used:**

- ASDU 1: time-tagged message
- ASDU 3: Measurands I
- ASDU 5: Identification message
- ASDU 6: Time synchronization
- ASDU 8: Termination of general interrogation.

### **The relay accepts:**

- ASDU 6: Time synchronization
- ASDU 7: Initiation of general interrogation
- ASDU 20: General command.
- ASDU 23: Disturbance recorder file transfer

### **The data in a message frame is identified by:**

- type identification
- function type
- information number.

These are fixed for data items in the compatible range of the protocol, for example, the trip of I> function is identified by: type identification = 1, function type = 160 and information number = 90. "Private range" function types are used for such data items that are not defined by the standard (for example, the status of the digital inputs and the control of the objects).

The function type and information number used in private range messages is configurable. This enables flexible interfacing to different master systems.

For more information on IEC 60870-5-103 in Easergy P3 relays, see the "IEC 103 Interoperability List.pdf" and "Communication parameter protocol mappings.zip" documents.

## 8.2.5 DNP 3.0

The relay supports communication using the DNP 3.0 protocol. The following DNP 3.0 data types are supported:

- binary input
- binary input change
- double-bit input
- binary output
- analog input
- counters

For more information, see the "DNP 3.0 Device Profile Document" and "Communication parameter protocol mappings.zip". DNP 3.0 communication is activated via menu selection. RS-485 interface is often used but also RS-232 and fibre optic interfaces are possible.

## 8.2.6 IEC 60870-5-101 (IEC-101)

The IEC 60870-5-101 standard is derived from the IEC 60870-5 protocol standard definition. In Easergy P3 relays, the IEC 60870-5-101 communication protocol is available via menu selection. The relay works as a controlled outstation (slave) unit in unbalanced mode.

The supported application functions include process data transmission, event transmission, command transmission, general interrogation, clock synchronization, transmission of integrated totals, and acquisition of transmission delay.

For more information on IEC 60870-5-101 in Easergy P3 relays, see the "Communication parameter protocol mappings.zip" document.

## 8.2.7 IEC 61850

The IEC 61850 protocol is available with the optional communication module. It can be used to read or write static data from the relay or to receive events and to receive or send GOOSE messages from or to other relays.

The IEC 61850 server interface contains:

- configurable data model: selection of logical nodes corresponding to active application functions
- configurable pre-defined data sets
- supported dynamic data sets created by clients
- supported reporting function with buffered and unbuffered Report Control Blocks
- sending analogue values over GOOSE
- supported control modes:
  - direct with normal security
  - direct with enhanced security
  - select before operation with normal security
  - select before operation with enhanced security
- supported horizontal communication with GOOSE: configurable GOOSE publisher data sets, configurable filters for GOOSE subscriber inputs, GOOSE inputs available in the application logic matrix

Additional information can be obtained from the separate documents "IEC 61850 interface in Easergy P3 relays configuration instruction.pdf" and "Communication parameter protocol mappings.zip".

## 8.2.8 EtherNet/IP

The relay supports communication using the EtherNet/IP protocol which is a part of the Common Industrial Protocol (CIP) family. The EtherNet/IP protocol is available with the optional inbuilt Ethernet port. The protocol can be used to read or write data from or to the relay using request / response communication or via cyclic messages transporting data assigned to assemblies (sets of data).

For more detailed information and parameter lists for EtherNet/IP, refer to a separate application note "EtherNet/IP configuration instructions.pdf".

For the complete data model of EtherNet/IP, refer to the document "DeviceNet and EtherNetIP data model.pdf" and "Communication parameter protocol mappings.zip".

### 8.2.9 HTTP server – Webset

The Webset HTTPS configuration interface provides the option to configure the relay with a standard web browser such as Internet Explorer, Mozilla Firefox, or Google Chrome. The feature is available when the communication option C, D, N or R is in use.

A subset of the relays's features is available in the Webset interface. The group list and group view from the relay are provided, and most groups, except the LOGIC and the MIMIC groups are configurable.

# 9

## Applications and configuration examples

This chapter describes the protection functions in different protection applications.

The relay can be used for line/feeder protection of medium voltage networks with a grounded, low-resistance grounded, isolated or a compensated neutral point. The relays have all the required functions to be applied as a backup relay in high-voltage networks or to a transformer differential relay. In addition, the relay includes all the required functions to be applied as a motor protection relay for rotating machines in industrial protection applications.

The relays provide a circuit breaker control function. Additional primary switching relays (earthing switches and disconnecter switches) can also be controlled from the front panel or the control or SCADA/automation system. A programmable logic function is also implemented in the relay for various applications, for example interlockings schemes.



# 9.1 Industrial motor protection

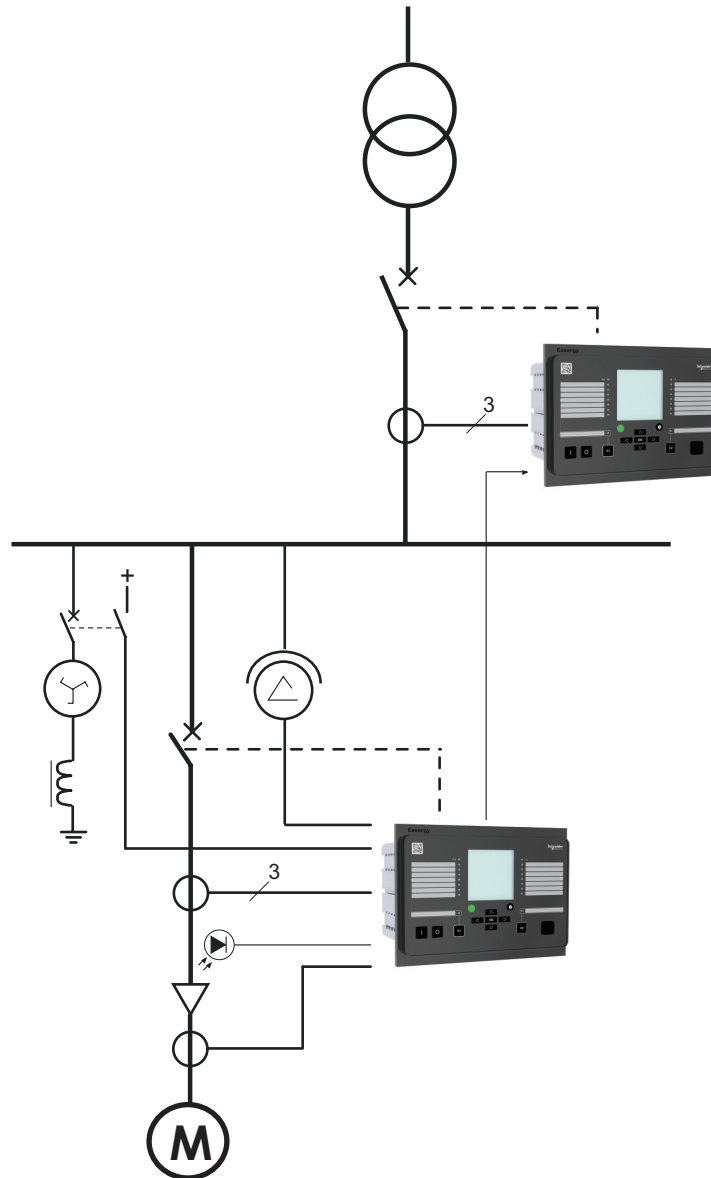

Figure 9.1: Easergy P3M30 and P3M32 used in cable protection of an industry plant network.

The relay supports directional earth fault protection and three-phase overcurrent protection which is required in a cable feeder. Furthermore, the thermal stage can be used to protect the cable against overloading. All necessary motor protection functions are supported when using motor application mode. This example also includes fast arc protection.

## 9.2 Using CSH120 and CSH200 with core balance CTs

### General

The CSH120 and CSH200 core balance CTs are for direct earth fault overcurrent measurement. The only difference between them is the diameter. Because of their low-voltage insulation, they can only be used on cables.

These core balance CTs can be connected to the Easergy P3 protection relay range when 0.2 A  $I_0$  input is used. This needs to be determined when ordering the protection relay (select 0.2 A for the earth fault current input in the order code).

### Settings in Easergy P3 protection relay

When CSH120 or CSH200 is connected to an Easergy P3 protection relay, to secure correct operation of the protection functions and measurement values, use the following values in the **Scaling** setting view:

- $I_{0X}$  CT primary: 470 A
- $I_{0X}$  CT secondary: 1 A
- Nominal  $I_{0X}$  input: 0.2 A

**NOTE:** X refers to the  $I_0$  input channel number (1 or 2).

I02 CT primary	<input type="text" value="470"/>	A
I02 CT secondary	<input type="text" value="1.0"/>	A
Nominal I02 input	<input type="text" value="0.2"/>	A

Figure 9.2: Scalings view for  $I_{02}$  input

### Measuring specifications

When CSH120 or CSH200 is used with Easergy P3 protection relays the measuring range is 0.2 A–300 A of primary current. The minimum setting for primary current is  $0.005 \times I_N$  which in this case means  $0.005 \times 470 \text{ A} = 2.35 \text{ A}$  of primary current.

Io input	Io2			
Io1 residual current	0.000			pu
Status	-			
Estimated time to trip	0.0			s
Start counter	0	<input type="button" value="Clear"/>		
Trip counter	0	<input type="button" value="Clear"/>		

---

Set group 1 DI control	-			
Set group 2 DI control	-			
Set group 3 DI control	-			
Set group 4 DI control	-			

---

Group	1			
	Group 1	Group 2	Group 3	Group 4
Pick-up setting [A]	2.35	23.50	23.50	23.50
Pick-up setting [pu]	0.005	0.050	0.050	0.050
Delay curve family	DT	DT	DT	DT
Delay type	DT	DT	DT	DT
Operation delay [s]	1.00	1.00	1.00	1.00

Figure 9.3: Earth fault overcurrent setting view

---

# 10 Installation

## 10.1 Checking the consignment

Check that the unit packaging and the seal are intact at the receipt of the delivery. Our products leave the factory in closed, sealed packaging. If the transport packaging is open or the seal is broken, the confidentiality and authenticity of the information contained in the products cannot be ensured.

## 10.2 Product identification

Each Easergy P3 relay is delivered in a separate package containing:

- Easergy P3 protection relay with the necessary terminal connectors
- Production testing certificate
- Quick Start manual

Optional accessories are delivered in separate packages.

To identify an Easergy P3 protection relay, see the labels on the package and on the side of the relay.

### Serial number label

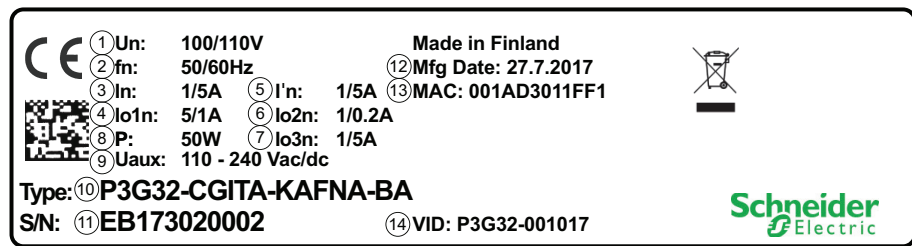

1. Rated voltage  $U_N$
  2. Rated frequency  $f_N$
  3. Rated phase current  $I_N$
  4. Rated earth fault current  $I_{01N}$
  5. Rated phase current  $I'_N$  (\*)
  6. Rated earth fault current  $I_{02N}$
  7. Rated earth fault current  $I_{03N}$  (\*)
  8. Power consumption
  9. Power supply operating range  $U_{AUX}$
  10. Order code
  11. Serial number
  12. Manufacturing date
  13. MAC address for TCP/IP communication
  14. Production identification
- \*) Available in P3M32, P3T32 and P3G32 models only

### Unit package label

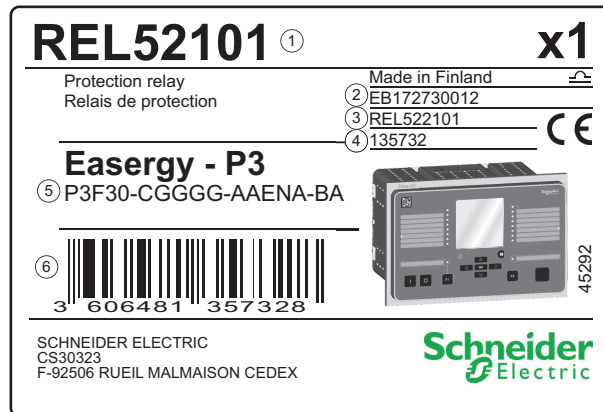

1. Short order code
2. Serial number
3. Short order code
4. Internal product code
5. Order code
6. EAN13 bar code

## 10.3 Storage

Store the relay in its original packaging in a closed, sheltered location with the following ambient conditions:

- ambient temperature: -40 °C to +70 °C (or -40 °F to +158 °F)
- humidity < 90 %.

Check the ambient conditions and the packaging yearly.

## 10.4 Mounting

### **⚠ DANGER**

#### **HAZARD OF ELECTRIC SHOCK, EXPLOSION, OR ARC FLASH**

- Wear your personal protective equipment (PPE) and comply with the safe electrical work practices. For clothing refer applicable local standards.
- Only qualified personnel should install this equipment. Such work should be performed only after reading this entire set of instructions and checking the technical characteristics of the relay.
- NEVER work alone.
- Turn off all power supplying this equipment before working on or inside it. Consider all sources of power, including the possibility of backfeeding.
- Always use a properly rated voltage sensing relay to ensure that all power is off.
- Do not open the secondary circuit of a live current transformer.
- Connect the relay's protective ground to functional earth according to the connection diagrams presented in this document.

**Failure to follow this instruction will result in death or serious injury.**

### **⚠ CAUTION**

#### **HAZARD OF CUTS**

Trim the edges of the cut-out plates to remove any jagged edges.

**Failure to follow these instructions can result in injury.**

Panel mounting

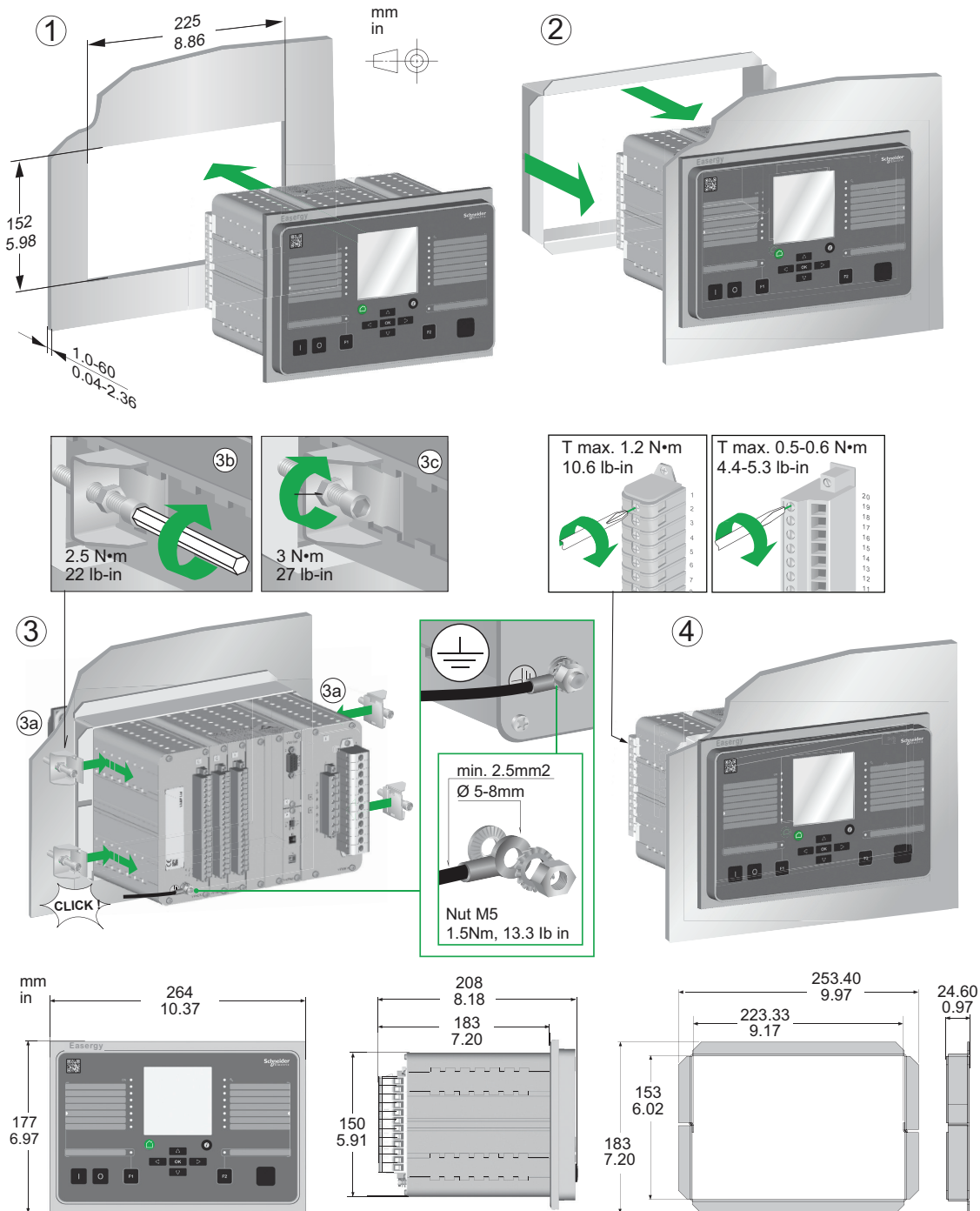

The conventional mounting technique has always been installing the relay on the secondary compartment's door. A limitation of this approach could be that the door construction is not strong enough for the relay's weight and wiring a large amount of secondary and communication cabling could be challenging.



Panel mounting with detachable display

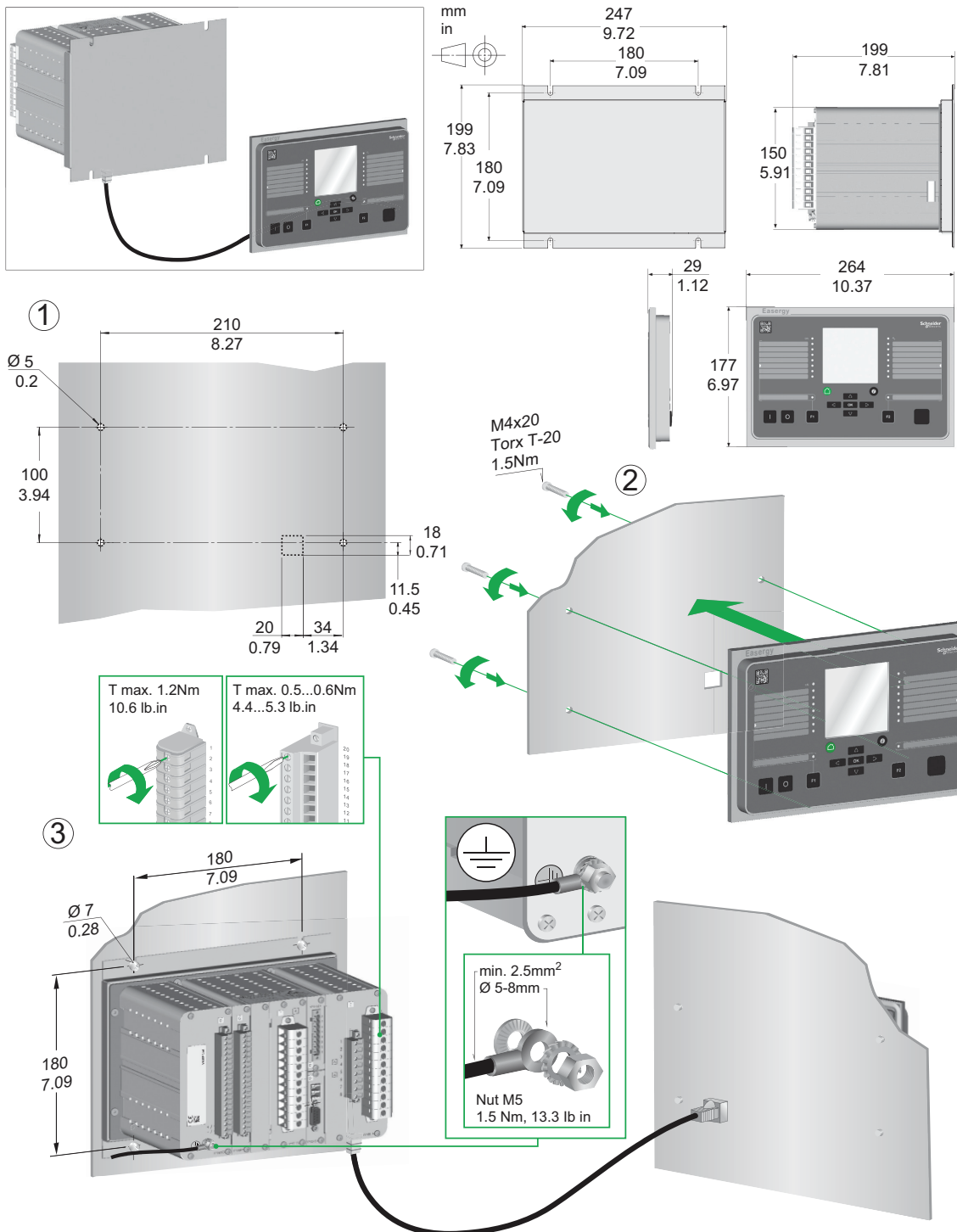

This mounting technique allows the door to be lighter as the relay's frame is installed on the back of the secondary compartment. Normally, the relay is mounted by the terminal blocks, hence the secondary wiring is short. Communication cabling is easier, too, as the door movement does not need to be considered. In this case, only the communication between relay base and display have to be wired.

Projection mounting

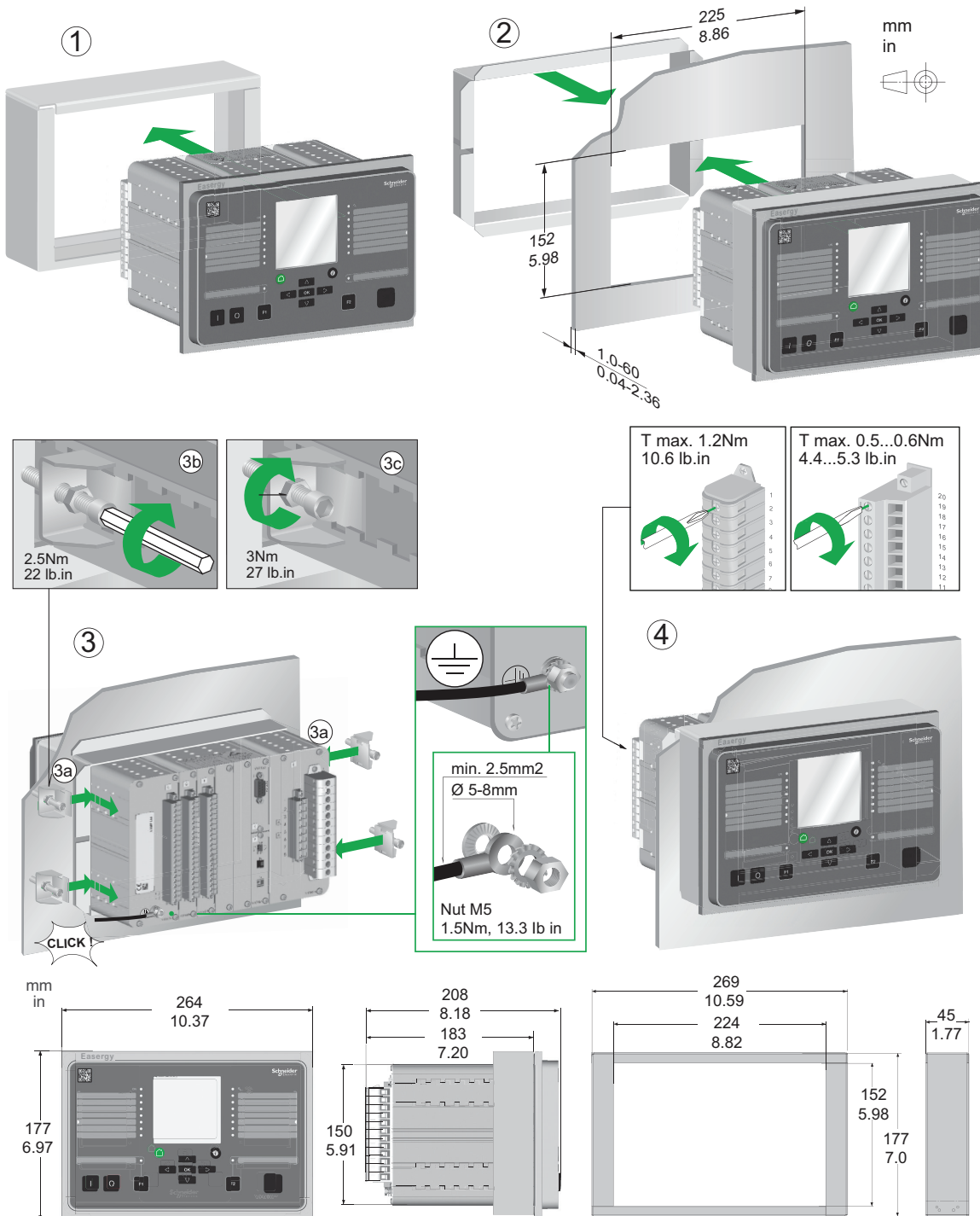

If the depth dimension behind the compartment door is limited, the relay can be equipped with a frame around the collar. This arrangement reduces the depth inside the compartment by 45 mm. More details please see Table 11.5.

**Example of the P3 alarm facial label insertion**

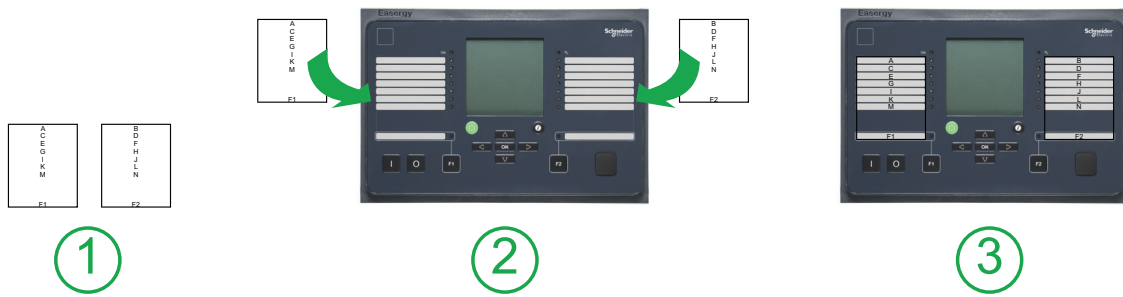

See "P3 Advanced Series facial label instruction" document for more information.

**Protective film**

<b><i>NOTICE</i></b>
<p><b>RISK OF DESTRUCTION OF THE RELAY</b></p> <p>The protective film on the relay's display is plastic and can melt if exposed to high temperatures intensive sunlight. Remove the protective film after mounting the relay.</p> <p><b>Failure to follow these instructions can result in equipment damage.</b></p>

## 10.5 Connections

The Easergy P3M30 and P3M32 has a fixed combination of analog interface, power supply, digital input and output, communication and arc flash protection cards as per the chosen order code. Do not remove cards from the relay's card slots in any circumstances.

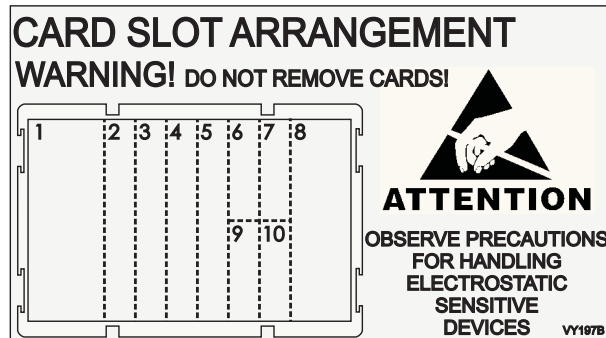

### 10.5.1 Supply voltage cards

#### Auxiliary voltage

**⚠ DANGER**

**HAZARD OF ELECTRIC SHOCK**

Before connecting the devices, disconnect the supply voltage to the unit.

**Failure to follow these instructions will result in death or serious injury.**

The external auxiliary voltage  $U_{AUX}$  (110–240 V ac/dc, or optionally 24–48 V dc) of the relay is connected to the pins 1/C/1:1–2 or 1/D/1:1–2.

**NOTE:** When an optional 24–48 V dc power module is used, the polarity is as follows: 1/D/2:2 positive (+), 1/D/2:1 negative (-).

**NOTICE**

**LOSS OF PROTECTION OR RISK OF NUISANCE TRIPPING**

- If the relay is no longer supplied with power or is in permanent fault state, the protection functions are no longer active and all the Easergy P3 digital outputs are dropped out.
- Check that the operating mode and SF relay wiring are compatible with the installation.

**Failure to follow these instructions can result in equipment damage and unwanted shutdown of the electrical installation.**



Figure 10.1: Example of supply voltage card Power C 110-240

Table 10.1: Supply voltage card Power C 110-240 & Power D 24-48

Pin No.	Symbol	Description
20	T12	Heavy duty trip relay 12 for arc protection
19	T12	Heavy duty trip relay 12 for arc protection
18	T11	Heavy duty trip relay 11 for arc protection
17	T11	Heavy duty trip relay 11 for arc protection
16	T10	Heavy duty trip relay 10 for arc protection
15	T10	Heavy duty trip relay 10 for arc protection
14	T9	Heavy duty trip relay 9 for arc protection
13	T9	Heavy duty trip relay 9 for arc protection
12	T1	Heavy duty trip relay 1 for arc protection
11	T1	Heavy duty trip relay 1 for arc protection
10	A1 NO	Signal relay 1, normal open connector
9	A1 NC	Signal relay 1, normal closed connector
8	A1 COMMON	Signal relay 1, common connector
7	SF NC	Service status output, normal closed
6	SF NO	Service status output, normal open
5	SF COMMON	Service status output, common
4		No connection
3		No connection
2	L / + / ~	Auxiliary voltage
1	N / - / ~	Auxiliary voltage

**⚠ DANGER****HAZARD OF ELECTRICAL SHOCK**

Connect the device's protective ground to functional earth according to the connection diagrams presented in this document.

**Failure to follow these instructions will result in death or serious injury.**

## 10.5.2 Analogue measurement cards

### **⚠ DANGER**

#### **HAZARD OF ELECTRICAL SHOCK**

Do not open the secondary circuit of a live current transformer.  
Disconnecting the secondary circuit of a live current transformer may cause dangerous overvoltages.

**Failure to follow these instructions will result in death or serious injury.**

10.5.2.1

**"E = 3L(5/1A) + 4U + 2I<sub>0</sub> (5/1A+1/0.2A)"**

This card contains connections for current transformers for measuring of the phase currents L1–L3 and two earth fault overcurrents I<sub>0</sub>, and four voltage transformers for measuring the U<sub>0</sub>, ULL or ULN.

The relay is able to measure three phase currents, and two earth fault overcurrents. It also measures up to four voltage signals: line-to-line, line-to-neutral, neutral displacement voltage and voltage from another side (synchrocheck). See the voltage modes selection below:

- 3LN+U<sub>0</sub>, 3LN+LL<sub>γ</sub>, 3LN+LN<sub>γ</sub>
- 2LL+U<sub>0</sub>+LL<sub>γ</sub>, 2LL+U<sub>0</sub>+LN<sub>γ</sub>
- LL+U<sub>0</sub>+LL<sub>γ</sub>+LL<sub>z</sub>, LN+U<sub>0</sub>+LN<sub>γ</sub>+LN<sub>z</sub>

**Table 10.2: Terminal pins 8/E/1:1–12**

Pin No.	Symbol	Description
1	IL1 (S1)	Phase current L1 5/1A (S1)
2	IL1 (S2)	Phase current L1 5/1A (S2)
3	IL2 (S1)	Phase current L2 5/1A (S1)
4	IL2 (S2)	Phase current L2 5/1A (S2)
5	IL3 (S1)	Phase current L3 5/1A (S1)
6	IL3 (S2)	Phase current L3 5/1A (S2)
7	Io1 (S1)	Earth fault overcurrent I <sub>01</sub> (S1) common for 5A and 1A
8	Io1 (S2)	Earth fault overcurrent I <sub>01</sub> 5A (S2)
9	Io1 (S2)	Earth fault overcurrent I <sub>01</sub> 1A (S2)
10	Io2 (S1)	Earth fault overcurrent I <sub>02</sub> (S1) common for 1A and 0.2A
11	Io2 (S2)	Earth fault overcurrent Io2 1A (S2)
12	Io2 (S2)	Earth fault overcurrent Io2 0.2A (S2)

**Table 10.3: Terminal pins 8/E/2:1–8**

Pin No.	Symbol	Description
1	ULL/ULN	Voltage ULL (a) /ULN (a)
2	ULL/ULN	Voltage ULL (b) /ULN (n)
3	ULL/ULN	Voltage ULL (a) /ULN (a)
4	ULL/ULN	Voltage ULL (b) /ULN (n)
5	Uo/ULL/ULN	Voltage Uo (a) / ULL (a) /ULN (a)
6	Uo/ULL/ULN	Voltage Uo (b) /ULL (b) /ULN (n)
7	Uo/ULN/ULL	Voltage Uo (da) / ULL (a) / ULN (n)
8	Uo/ULN/ULL	Voltage Uo (dn) / ULL (b) / ULN (n)

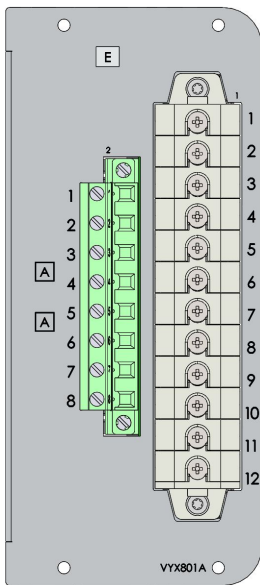

Figure 10.2: Analogue measurement card "E"



10.5.2.2

**"F = 3L(1A) + 4U + 2I<sub>0</sub> (5/1A+1/0.2A)"**

This card contains connections for current transformers for measuring the phase currents L1–L3 and two earth fault overcurrents I<sub>0</sub> and four voltage transformers for measuring the U<sub>0</sub>, ULL or ULN.

The relay is able to measure three phase currents, and two earth fault overcurrents. It also measures up to four voltage signals: line-to-line, line-to-neutral, zero-sequence voltage and voltage from another side (synchro-check). See the voltage modes selection below:

- 3LN+U<sub>0</sub>, 3LN+LL<sub>Y</sub>, 3LN+LN<sub>Y</sub>
- 2LL+U<sub>0</sub>+LL<sub>Y</sub>, 2LL+U<sub>0</sub>+LN<sub>Y</sub>
- LL+U<sub>0</sub>+LL<sub>Y</sub>+LL<sub>Z</sub>, LN+U<sub>0</sub>+LN<sub>Y</sub>+LN<sub>Z</sub>

**Table 10.4: Terminal pins 8/F/1:1–12**

Pin No.	Symbol	Description
1	IL1 (S1)	Phase current L1 1A (S1)
2	IL1 (S2)	Phase current L1 1A (S2)
3	IL2 (S1)	Phase current L2 1A (S1)
4	IL2 (S2)	Phase current L2 1A (S2)
5	IL3 (S1)	Phase current L3 1A (S1)
6	IL3 (S2)	Phase current L3 1A (S2)
7	Io1 (S1)	Earth fault overcurrent I <sub>01</sub> (S1) common for 5A and 1A
8	Io1 (S2)	Earth fault overcurrent I <sub>01</sub> 5A (S2)
9	Io2 (S2)	Earth fault overcurrent I <sub>01</sub> 1A (S2)
10	Io2 (S1)	Earth fault overcurrent I <sub>02</sub> (S1) common for 1A and 0.2A
11	Io2 (S2)	Earth fault overcurrent Io2 1A (S2)
12	Io2 (S2)	Earth fault overcurrent Io2 0.2A (S2)

**Table 10.5: Terminal pins 8/F/2:1–8**

Pin No.	Symbol	Description
1	ULL/ULN	Voltage ULL (a) /ULN (a)
2	ULL/ULN	Voltage ULL (b) /ULN (n)
3	ULL/ULN	Voltage ULL (a) /ULN (a)
4	ULL/ULN	Voltage ULL (b) /ULN (n)
5	ULL/ULN	Voltage ULL (a) /ULN (a)
6	ULL/ULN	Voltage ULL (b) /ULN (n)
7	U <sub>0</sub> /ULL/ULN	U <sub>0</sub> (da) / ULL (a) / ULN (a)
8	U <sub>0</sub> /ULL/ULN	U <sub>0</sub> (dn) / ULL (b) / ULN (n)

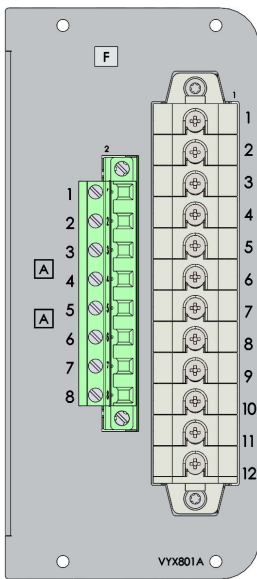

Figure 10.3: Analogue measurement card "F"

10.5.2.3

**“ $T = 3 \times I (5/1A) + I_0 (5/1A)$ ”**

This card contains connections for current measurement transformers for measuring the phase currents L1, L2 and L3 and earth fault overcurrent  $I_0$ .

Totally, the relay is able to measure six phase currents, three earth fault overcurrents and additionally four voltages.

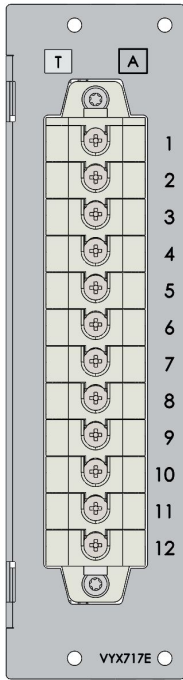

Figure 10.4: Analogue measurement card "T"

Table 10.6: Pins 4/A/1:1 – 12

Pin No.	Symbol	Description
1	I'L1	Phase current I'L1 (S1), common for 1A and 5A
2	I'L1 / 5A	Phase current I'L1 (S2)
3	I'L1 / 1A	Phase current I'L1 (S2)
4	I'L2	Phase current I'L2 (S1), common for 1A and 5A
5	I'L2 / 5A	Phase current I'L2 (S2)
6	I'L2 / 1A	Phase current I'L2 (S2)
7	I'L3	Phase current I'L3 (S1), common for 1A and 5A
8	I'L3 / 5A	Phase current I'L3 (S2)
9	I'L3 / 1A	Phase current I'L3 (S2)
10	I'o1	Earth fault overcurrent I'o1 (S1), common for 1A and 5A
11	I'o1 / 5A	Earth fault overcurrent I'o1 (S2)
12	I'o1 / 1A	Earth fault overcurrent I'o1 (S2)

### 10.5.3 I/O cards

#### 10.5.3.1 I/O card “G = 6DI+4DO”

This card provides 6 digital inputs and 4 relays outputs. The threshold level is selectable in the order code.

The card is equipped with 6 dry digital inputs with hardware-selectable activation/threshold voltage and four trip contacts. Input and output contacts are normally open.

**Table 10.7: Slots 2–5/G/1:1–20**

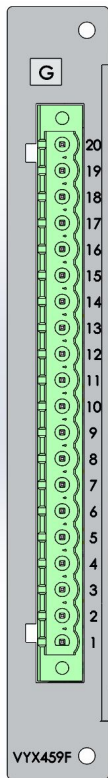

Pin No.	Symbol	Description
20	Tx	Trip relay
19		
18	Tx	Trip relay
17		
16	Tx	Trip relay
15		
14	Tx	Trip relay
13		
12	DIx	Digital input
11		
10	DIx	Digital input
9		
8	DIx	Digital input
7		
6	DIx	Digital input
5		
4	DIx	Digital input
3		
2	DIx	Digital input
1		

**NOTE:** Digital inputs are polarity free which means that the user can freely choose "-" and "+" terminals to each digital input.

### 10.5.3.2 I/O card "I = 10DI"

This card provides 10 digital inputs. The threshold level is selectable in the order code.

**Table 10.8: Slots 2–5/I/1:1–20**

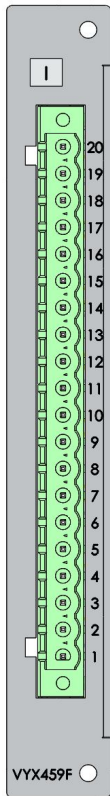

Pin No.	Symbol	Description
20	DIx	Digital input
19		
18	DIx	Digital input
17		
16	DIx	Digital input
15		
14	DIx	Digital input
13		
12	DIx	Digital input
11		
10	DIx	Digital input
9		
8	DIx	Digital input
7		
6	DIx	Digital input
5		
4	DIx	Digital input
3		
2	DIx	Digital input
1		

**NOTE:** Digital inputs are polarity-free which means that you can freely choose "-" and "+" terminals for each digital input.

### 10.5.3.3 I/O card “H = 6DI + 4DO (NC)”

This card provides 6 digital inputs and 4 relays outputs which are normally closed (NC). The threshold level is selectable in the order code.

The 6xDI+4xDO option card is equipped with 6 dry digital inputs with hardware-selectable activation/threshold voltage and four normally closed (NC) trip contacts.

**Table 10.9: Slots 2–5/G/1:1–20**

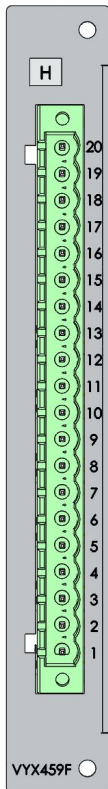

Pin No.	Symbol	Description
20	Tx	Trip relay
19		
18	Tx	Trip relay
17		
16	Tx	Trip relay
15		
14	Tx	Trip relay
13		
12	DIx	Digital input
11		
10	DIx	Digital input
9		
8	DIx	Digital input
7		
6	DIx	Digital input
5		
4	DIx	Digital input
3		
2	DIx	Digital input
1		

### 10.5.4 I/O option card “D= 4Arc”

This card contains 4 arc point connections to 4 arc light sensors (e.g. VA 1 DA). The card provides sensors 3 to 6.

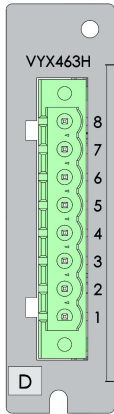

**Table 10.10: Pins 6/D/1:1–8 (slot 6)**



Pin No.	Symbol	Description
8	Sen 6 -	Arc sensor 6 negative terminal
7	Sen 6 +	Arc sensor 6 positive terminal
6	Sen 5 -	Arc sensor 5 negative terminal
5	Sen 5 +	Arc sensor 5 positive terminal
4	Sen 4 -	Arc sensor 4 negative terminal
3	Sen 4 +	Arc sensor 4 positive terminal
2	Sen 3 -	Arc sensor 3 negative terminal
1	Sen 3 +	Arc sensor 3 positive terminal

### 10.5.5 Communication cards

The communication card types and their pin assignments are introduced in Table 10.11.

**Table 10.11: Communication option modules and their pin numbering**

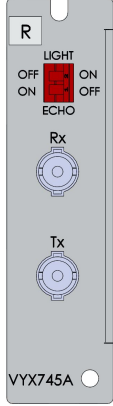
Type	Communication ports	Signal levels	Connectors	Pin usage
FibrePP (Slot 6 and 9)	Plastic fibre interface COM 1 port (if Slot 6 card) COM 3 port (if Slot 9 card)		Versatile Link fiber  The diagram shows a vertical communication card labeled VYX746A. It features a 'P' label at the top, a 'LIGHT' indicator with 'OFF' and 'ON' positions, an 'ECHO' indicator, an 'Rx' (Receiver) port, and a 'Tx' (Transmitter) port.	

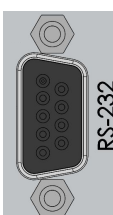
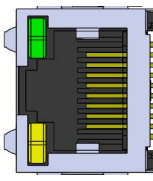
Type	Communication ports	Signal levels	Connectors	Pin usage
FibreGG (Slot 6 and 9)	Glass fibre interface (62.5/125 µm) COM 1 port (if Slot 6 card) COM 3 port (if Slot 9 card)		ST 	
232 (Slot 6)	COM 1 / COM 2	RS-232	D-connector 	1 = TX COM 2 2 = TX COM 1 3 = RX COM 1 7 = GND 8 = RX COM 2 9 = +12V
232 (Slot 9)	COM 3 / COM 4	RS-232	D-connector 	1 = TX COM 4 2 = TX COM 3 3 = RX COM 3 4 = IRIG-B 5 = IRIG-B GND 6 = 7 = GND 8 = RX COM 4 9 = +12V
232+Eth RJ (Slot 9)	COM 3 / COM 4	RS-232	D-connector 	1 = TX COM 4 2 = TX COM 3 3 = RX COM 3 4 = IRIG-B 5 = IRIG-B GND 6 = 7 = GND 8 = RX COM 4 9 = +12V
	ETHERNET	ETHERNET 100 Mbps	RJ-45 	1 = Transmit + 2 = Transmit - 3 = Receive + 4 = 5 = 6 = Receive - 7 = 8 =

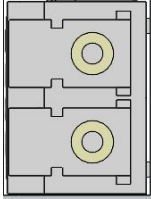
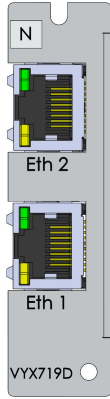
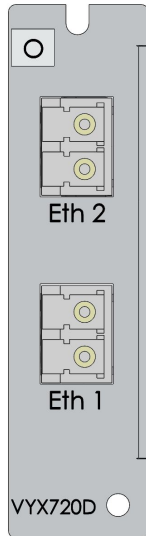
Type	Communication ports	Signal levels	Connectors	Pin usage
232+Eth LC (Slot 9)	COM 3 / COM 4	RS-232	D-connector 	1 = TX COM 4 2 = TX COM 3 3 = RX COM 3 4 = IRIG-B 5 = IRIG-B GND 6 = 7 = GND 8 = RX COM 4 9 = +12V
	ETHERNET	Light 100 Mbps	LC fiber connector 	1 = Receive 2 = Transmit
2EthRJ (Slot 9)	100Mbps Ethernet interface with IEC 61850	ETHERNET 100 Mbps	2 x RJ-45 	1=Transmit+ 2=Transmit- 3=Receive+ 4= 5= 6=Receive- 7= 8=
2EthLC (Slot 9)	100 Mbps Ethernet fibre interface with IEC 61850	Light 100 Mbps	2 x LC 	LC-connector from top: -Port 2 Tx -Port 2 Rx -Port 1 Tx -Port 1 Rx

**NOTE:** When a communication option module of type B, C or D is used in slot 9, serial ports COM 3 / COM 4 are available.



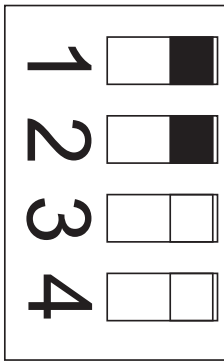

Figure 10.5: Dip switches in optic fibre options.

Dip switch number	Switch position	Function Fibre optics
1	Left	Echo off
1	Right	Echo on
2	Left	Light on in idle state
2	Right	Light off in idle state
3	Left	Not applicable
3	Right	Not applicable
4	Left	Not applicable
4	Right	Not applicable

### 10.5.5.1

### COM 3–COM 4 ports

COM 3 and COM 4 PORT are ports for serial communication protocols. The type of the physical interface on these ports depends on the type of the selected communication option module. The use of some protocols may require a certain type of option module. The parameters for these ports are set via the front panel or with Easergy Pro in menus COM 3 PORT – COM 4 PORT.

Communication information is normally sent to the control system (SCADA), but it is also possible to use certain communication-related notifications internally, for example alarms. This is can be done for example via the logic and different matrices.

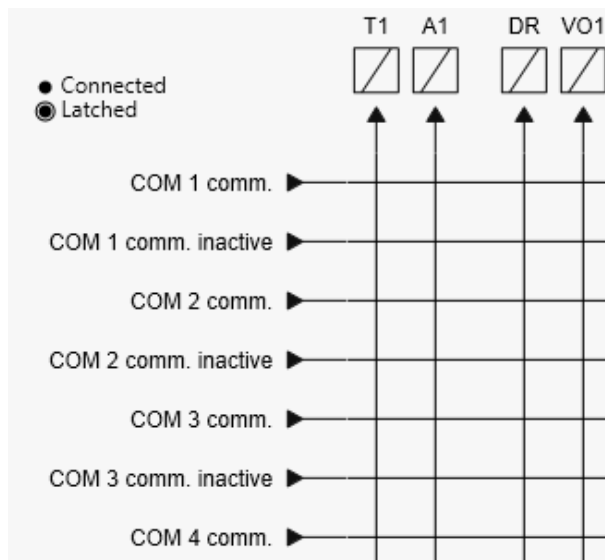



Figure 10.6: Communication-related notifications can be connected to trip contacts in the “output matrix” menu.

**Table 10.12: COM 3 port**

Type	External module	Order code	Cable / order code	Typically used protocols
232+00 or 232+Eth RJ or 232+Eth LC (Slot 9) 	None	None	None	-None -IEC-101 -IRIG-B -GetSet
	VSE-009	VSE009	None	-None -DeviceNet
	VIO12-AB and VSE-002	VIO 12 AB  VSE002	None	-None -ExternalIO
	VIO12-AC and VSE-002	VIO 12 AC  VSE002	None	-None -ExternalIO
	VIO12-AD and VSE-002	VIO 12 AD  VSE002	None	-None -ExternalIO
	VSE-001	VSE001	None	-None -IEC-103 -ModbusSiv -SpaBus
	VSE-002	VSE002	None	-None -IEC-103 -ModbusSiv -SpaBus -DNP3
	VPA-3CG	VPA3CG	VX072	-None -ProfibusDP

To be able to use COM 4 port, the RS-232 communication interface (Option B, C or D) has to be split in two by using a VX067 cable. When the VX-067 cable is connected, the below-mentioned protocols can be used in the COM 4 port:

**Table 10.13: COM 4 port**

Type	External module	Order code	Cable / order code	Typically used protocols
232+00 or 232+Eth RJ or 232+Eth LC +VX067 (Split cable) (Slot 9) 	None	None	None	-None -IEC-101 -IRIG-B -GetSet
	VSE-009	VSE-009	None	-None -DeviceNet
	VIO12-AB and VSE-002	VIO 12 AB  VSE002	None	-None -ExternalIO
	VIO12-AC and VSE-002	VIO 12 AC  VSE002	None	-None -ExternalIO
	VIO12-AD and VSE-002	VIO 12 AD  VSE002	None	-None -ExternalIO
	VSE-001	VSE001	None	-None -IEC-103 -ModbusSiv -SpaBus
	VSE-002	VSE002	None	-None -IEC-103 -ModbusSiv -SpaBus -DNP3
	VPA-3CG	VPA3CG	VX068	-None -ProfibusDP

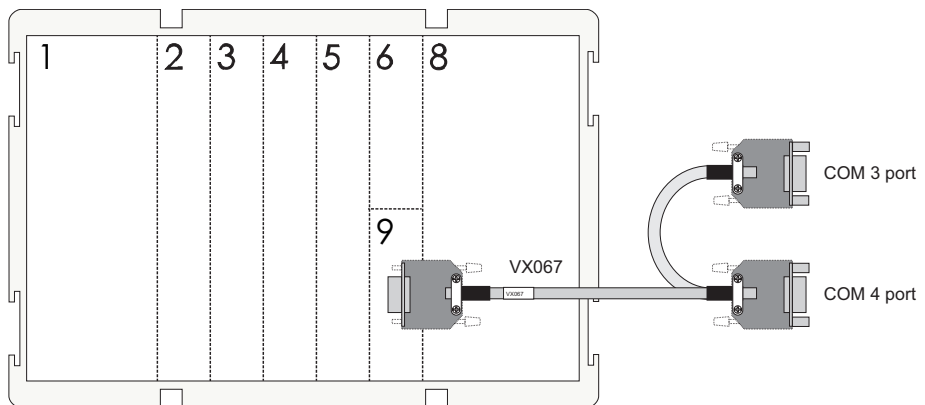

*Figure 10.7: To be able to use COM 3 and COM 4 ports, VX067 must be used on the D-connector of slot 9 option card.*

**NOTE:** It is possible to use 2 serial communication protocols simultaneously but the restriction is that the same protocol can be used only once.

The protocol configuration menu contains the selection for the protocol, port settings and message/error/timeout counters.

**COM 1 PORT**

Enable communication port  ↻

COM 1 port protocol IEC-103 ↻

- 9600/8N1

Message counter 0 Clear

Error counter 0 Clear

Timeout counter 0 Clear

---

**COM 2 PORT**

Enable communication port  ↻

COM 2 port protocol ProfibusDP ↻

- 9600/8N1

Message counter 0 Clear

Error counter 0 Clear

Timeout counter 0 Clear

Figure 10.8: Protocols can be enabled in the “protocol configuration” menu. Only serial communication protocols are valid with the RS-232 interface.

Table 10.14: Parameters

Parameter	Value	Unit	Description	Note
Protocol			Protocol selection for COM port	Set
	None		-	
	SPA-bus		SPA-bus (slave)	
	ProfibusDP		Interface to Profibus DB module VPA 3CG (slave)	
	ModbusSlv		Modbus RTU slave	
	IEC-103		IEC-60870-5-103 (slave)	
	ExternalIO		Modbus RTU master for external I/O-modules	
	IEC 101		IEC-608670-5-101	
	DNP3		DNP 3.0	
	DeviceNet		Interface to DeviceNet module VSE 009	
GetSet		Communicationi protocols for Easergy Pro interface		
Msg#	0 – 2 <sup>32</sup> - 1		Message counter since the relay has restarted or since last clearing	Clr
Errors	0 – 2 <sup>16</sup> - 1		Protocol interruption since the relay has restarted or since last clearing	Clr
Tout	0 – 2 <sup>16</sup> - 1		Timeout interruption since the relay has restarted or since last clearing	Clr

---

Parameter	Value	Unit	Description	Note
	speed/DPS		Display of current communication parameters. speed = bit/s D = number of data bits P = parity: none, even, odd S = number of stop bits	1.

Set = An editable parameter (password needed). Clr = Clearing to zero is possible.

1. The communication parameters are set in the protocol-specific menus. For the local port command line interface, the parameters are set in the configuration menu.

---

## 10.5.6 Local port (Front panel)

The relay has a USB port in the front panel.

### Protocol for the USB port

The front panel USB type B port is always using the command line protocol for Easergy Pro.

The speed of the interface is defined in the CONF/DEVICE SETUP menu via the front panel. The default settings for the relay are 38400/8N1.

It is possible to change the front USB port's bit rate. This setting is visible only on the relay's local display. The bit rate can be set between 1200 and 187500. This changes the bit rate of the relay, and the Easergy Pro bit rate has to be set separately. If the bit rate in the setting tool is incorrect, it takes a longer time to establish the communication.

**NOTE:** Use the same bit rate in the relay and the Easergy Pro setting tool.

## 10.5.7 Connection data

**Table 10.15: Auxiliary power supply**

$U_{AUX}$	110 (-20%) – 240 (+10%) V ac/dc 110/120/220/240 V ac 110/125/220 V dc or 24–48 $\pm$ 20% V dc 24/48 V dc
Power consumption - Normal state - Maximum state (all outputs activated)	< 20 W < 28 W
Terminal block: - MSTB2.5–5.08	Wire cross section: Maximum 2.5 mm <sup>2</sup> (13–14 AWG) Minimum 1.5 mm <sup>2</sup> (15–16 AWG) Wire type: single strand or stranded with insulated crimp terminal

**Table 10.16: Digital inputs technical data**

Number of inputs	As per the order code
Voltage withstand	255 V ac/dc
(as per the order code letters) Nominal operation voltage for DI inputs	A: 24–230 V ac/dc (max. 255 V ac/dc) B: 110–230 V ac/dc (max. 255 V ac/dc) C: 220–230 V ac/dc (max. 255 V ac/dc)
Typical switching threshold (as per order code letters)	A: 12 V dc B: 75 V dc C: 155 V dc
Current drain	< 4 mA (typical approx. 3mA)
Cycle time	10 ms
Activation time dc/ac	< 11 ms / < 15 ms
Reset time dc/ac	< 11 ms / < 15 ms
Terminal block: - MSTB2.5–5.08	Wire cross section: Maximum 2.5 mm <sup>2</sup> (13–14 AWG) Minimum 1.5 mm <sup>2</sup> (15–16 AWG) Wire type: single strand or stranded with insulated crimp terminal

**NOTE:** Set the dc/ac mode according to the used voltage in Easergy Pro.

**Table 10.17: Trip contact, high break**

Number of contacts	5 normal open contacts
Rated voltage	250 V ac/dc
Continuous carry	5 A
Minimum making current	100 mA @ 24 Vdc
Make and carry, 0.5 s at duty cycle 10%	30 A
Make and carry, 3 s at duty cycle 10%	15 A
Breaking capacity, AC	2 000 VA
Breaking capacity, DC (L/R=40ms)	
at 48 V dc:	5 A
at 110 V dc:	3 A
at 220 V dc	1 A
Contact material	AgNi 90/10
Terminal block: - MSTB2.5–5.08	Wire cross section: Maximum 2.5 mm <sup>2</sup> (13–14 AWG) Minimum 1.5 mm <sup>2</sup> (15–16 AWG) Wire type: single strand or stranded with insulated crimp terminal

**NOTE:** High-break trip contacts exist in power module C and D only.

**Table 10.18: Trip contact, Tx**

Number of contacts	As per the order code
Rated voltage	250 V ac/dc
Continuous carry	5 A
Minimum making current	100 mA at 24 Vdc
Make and carry, 0.5 s	30 A
Make and carry, 3 s	15 A
Breaking capacity, ac	2 000 VA
Breaking capacity, dc (L/R = 40ms)	
at 48 V dc:	1.15 A
at 110 V dc:	0.5 A
at 220 V dc:	0.25 A
Contact material	AgNi 90/10
Terminal block: - MSTB2.5 - 5.08	Wire cross section: Maximum 2.5 mm <sup>2</sup> (13–14 AWG) Minimum 1.5 mm <sup>2</sup> (15–16 AWG) Wire type: single strand or stranded with insulated crimp terminal



**Table 10.19: Signal contact, A1**

Number of contacts:	1
Rated voltage	250 V ac/dc
Continuous carry	5 A
Minimum making current	100 mA at 24 V ac/dc
Breaking capacity, dc (L/R = 40ms)	
at 48 V dc:	1 A
at 110 V dc:	0.3 A
at 220 V dc:	0.15 A
Contact material	AgNi 0.15 gold plated
Terminal block - MSTB2.5 - 5.08	Wire cross section Maximum 2.5 mm <sup>2</sup> (13–14 AWG) Minimum 1.5 mm <sup>2</sup> (15–16 AWG) Wire type: single strand or stranded with insulated crimp terminal

**Table 10.20: Signal contact, SF**

Number of contacts:	1
Rated voltage	250 V ac/dc
Continuous carry	5 A
Minimum making current	100 mA @ 24 V ac/dc
Breaking capacity, DC (L/R = 40ms)	
at 48 V dc:	1 A
at 110 V dc:	0.3 A
at 220 V dc	0.15 A
Contact material	AgNi 0.15 gold plated
Terminal block - MSTB2.5 - 5.08	Wire cross section Maximum 2.5 mm <sup>2</sup> (13–14 AWG) Minimum 1.5 mm <sup>2</sup> (15–16 AWG) Wire type: single strand or stranded with insulated crimp terminal

**Table 10.21: Local serial communication port**

Number of ports	1 on front
Electrical connection	USB
Data transfer rate	1 200 – 187 500 b/s
Protocols	GetSet

**Table 10.22: COM 3-4 serial communication port**

Number of physical ports	0 - 1 on rear panel (option)
Electrical connection	RS-232 (option, IRIG-B included) RS-485 (option) Profibus (option, external module) Glass fibre connection (option, external module)
Protocols	Modbus RTU, master Modbus RTU, slave Spabus, slave IEC 60870-5-103 IEC 61870-5-101 Profibus DP DNP 3.0 IRIG-B

**Table 10.23: Ethernet communication port**

Number of ports	0-2 on rear panel (option)
Electrical connection	RJ-45 100 Mbps (option) LC 100Mbps (option)
Protocols	IEC 61850 Modbus TCP DNP 3.0 EtherNet/IP IEC 61870-5-101

**Table 10.24: Fiber Ethernet communication port**

Number of ports	0 or 2 on rear panel (option)
Connection type	LC 100 Mbps
Optical Characteristics:	Operates with 62.5/125 $\mu$ m and 50/125 $\mu$ m multimode fiber Center Wavelength: 1300 nm typical Output Optical Power: <ul style="list-style-type: none"> <li>• Fiber: 62.5/125 <math>\mu</math>m, NA = 0.275 23.0 dBm</li> <li>• Fiber: 50/125 <math>\mu</math>m, NA = 0.20 26.0 dBm</li> </ul> Input Optical Power: -31 dBm
Protocols	IEC 61850 Modbus TCP DNP 3.0 EtherNet/IP IEC 61870-5-101

**Table 10.25: BIO inputs/outputs, slot 2 option B**

Rated output voltage	+30 V dc
Rated input voltage	+18 – 265 V dc
Rated current (BO)	20 mA
Rated current (BI)	5 mA
BI line (IN)	3 x BI inputs
BO lines (OUT)	3 x BO inputs
Connection cable	Twisted pair with shield. Shield shall be grounded.

**Table 10.26: BIO inputs/outputs, slot 2 option C**

Maximum number of Inputs	4 x inputs
Connector	ST
Fibre	50/125 $\mu\text{m}$ , 62.5/125 $\mu\text{m}$ , 100/140 $\mu\text{m}$ , and 200 $\mu\text{m}$
Max link distance	2 km (62.5/125 $\mu\text{m}$ )
Max link attenuation	7 db
BI line (IN)	2 pcs
BO lines ( OUT )	2 pcs

**Table 10.27: Arc sensor inputs**

Number of inputs	As per the order code
Supply to sensor	Isolated 12 V dc

Table 10.28: Measuring circuits

Phase current inputs I' (5/1 A)	Slot 4: $T = 3 \times I (5/1A) + I_0 (5/1A)$	
Rated phase current	5 A	1 A
- Current measuring range	0.05–250 A	0.02–50 A
- Thermal withstand		
• continuously	20 A	4 A
• 10 s	100 A	20 A
• 1 s	500 A	100 A
• 10 ms	1250 A	250 A
- Burden	0.075 VA	0.02 VA
- Impedance	0.003 Ohm	0.02 Ohm
$I_0$ input (5A and 1A)		
Rated earth fault overcurrent	5 A	1 A
- Current measuring range	0.05–250 A	0.02–50 A
- Thermal withstand		
• continuously	20 A	4 A
• 10 s	100 A	20 A
• 1 s	500 A	100 A
- Burden	0.075 VA	0.02 VA
- Impedance	0.003 Ohm	0.02 Ohm
Phase current inputs I (1A, 5 A)	Slot 8: $E = 3L (5/1A) + 4U + 2I_0 (5/1A+1/0.2A)$	- $F = 3L (1 A) + 4U + 2I_0 (5/1A+1/0.2A)$
Rated phase current	5 A	1A
- Current measuring range	0.05–250 A	0.02–50 A
- Thermal withstand		
• continuously	20 A	4 A
• 10 s	100 A	20 A
• 1 s	500 A	100 A
• 10 ms	1250 A	250 A
- Burden	0.075 VA	0.02 VA
- Impedance	0.003 Ohm	0.02 Ohm
$I_0$ input (5 A)	Slot 8: $E = 3L (5/1A) + 4U + 2I_0 (5/1A+1/0.2A)$	
Rated earth fault overcurrent	5 A (configurable for CT secondaries 0.1–10 A)	
- Current measuring range	0.015–50 A	
- Thermal withstand		
• continuously	20 A	
• 10 s	100 A	
• 1 s	500 A	
- Burden	0.075 VA	
- Impedance	0.003 Ohm	
$I_0$ input (1 A)	Slot 8: $E = 3L (5/1A) + 4U + 2I_0 (5/1A+1/0.2A)$	
Rated earth fault overcurrent	1 A (configurable for CT secondaries 0.1 – 10.0 A)	
- Current measuring range	0.003–10 A	
- Thermal withstand		
• continuously	4 A	
• 10 s	20 A	
• 1 s	100 A	
- Burden	0.02 VA	
- Impedance	0.02 Ohm	

<b>I<sub>0</sub> input (0.2 A)</b>	<b>Slot 8:</b> E = 3L (5/1A) + 4U + 2I <sub>0</sub> (5/1A+1/0.2A)
Rated earth fault overcurrent - Current measuring range - Thermal withstand	0.2 A (configurable for CT secondaries 0.1 – 10.0 A) 0.0006–2 A
• continuously	0.8 A
• 10 s	4 A
• 1 s	20 A
- Burden	0.02 VA
- Impedance	0.02 Ohm
<b>Voltage inputs</b>	
Rated voltage U <sub>N</sub> - Voltage measuring range - Thermal withstand	100 V (configurable for VT secondaries 50–250 V) 0.5–190 V (100 V / 110 V)
• continuously	250 V
• 10 s	600 V
- Burden	< 0.5 VA
<b>Frequency</b>	
Rated frequency f <sub>N</sub> Measuring range	45–65 Hz (protection operates accurately) 16–95 Hz < 44Hz / > 66Hz (other protection is not steady except frequency protection)

**Table 10.29: Analog interface cross section and tightening torque**

Terminal characteristics		
	Current inputs	Voltage inputs
Maximum wire cross section, mm <sup>2</sup> (AWG)	4 (10-12)	2.5 (13-14)
Maximum wiring screw tightening torque Nm (lb-in)	1.2 (10.6)	0.5-0.6 (4.4-5.3)
Maximum connector retention tightening torque Nm (lb-in)	-	0.3-0.4 (2.7-3.5)
Wire type	Single strand or stranded with insulated crimp terminal	

## 10.5.8 External option modules

### 10.5.8.1 VSE-001 fiber optic interface module

#### **⚠ DANGER**

##### **HAZARD OF ELECTRIC SHOCK, EXPLOSION, OR ARC FLASH**

- This equipment must only be installed or serviced by qualified electrical personnel.
- Turn off all power supplying this device and the equipment in which it is installed before working on the device or equipment.
- Connect protective ground (earth) before turning on any power supplying this device.

**Failure to follow these instructions will result in death or serious injury.**

An external fiber optic module VSE-001 is used to connect the relay to a fiber optic loop or a fiber optic star. There are four different types of serial fiber optic modules:

- VSE001PP (Plastic - plastic)
- VSE001GG (Glass - glass)

The modules provide a serial communication link up to 1 km (0.62 miles) with VSE 001 GG. With a serial fibre interface module it is possible to have the following serial protocols in use:

- None
- IEC-103
- Modbus slave
- SpaBus

The power for the module is taken from pin 9 of the D-connector or from an external power supply interface.

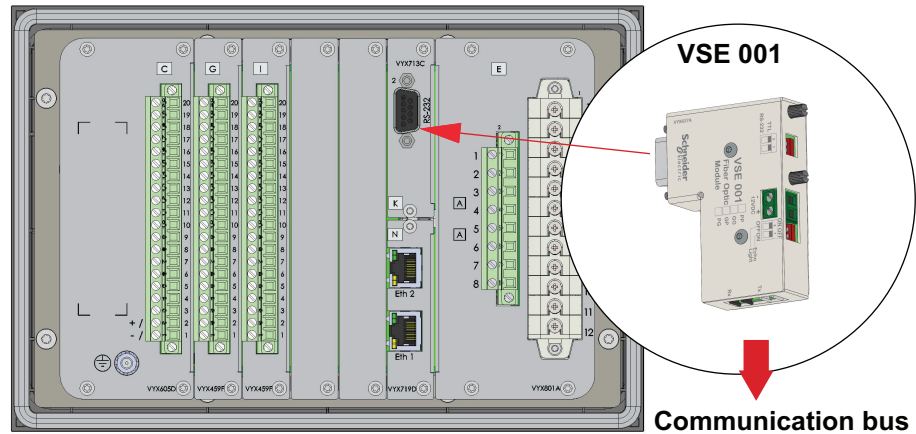

Figure 10.9: The VSE-001 module brings a serial-fiber interface to the relay. The Module is connected to the RS-232 serial port.

### Module interface to the relay

The physical interface of the VSE-001 is a 9-pin D-connector. The signal level is RS-232.

**NOTE:** The product manual for VSE-001 can be found on our website.

10.5.8.2 VSE-002 RS-485 interface module

**⚠ DANGER**

**HAZARD OF ELECTRIC SHOCK, EXPLOSION, OR ARC FLASH**

- This equipment must only be installed or serviced by qualified electrical personnel.
- Turn off all power supplying this device and the equipment in which it is installed before working on the device or equipment.
- Connect protective ground (earth) before turning on any power supplying this device.

**Failure to follow these instructions will result in death or serious injury.**

An external RS-485 module VSE-002 (VSE002) is used to connect Easergy P3 protection relays to RS-485 bus. With the RS-485 serial interface module, the following serial protocols can be used:

- None
- IEC-103
- ModbusSlv
- SpaBus

The power for the module is taken from pin 9 of the D-connector or from an external power supply interface.

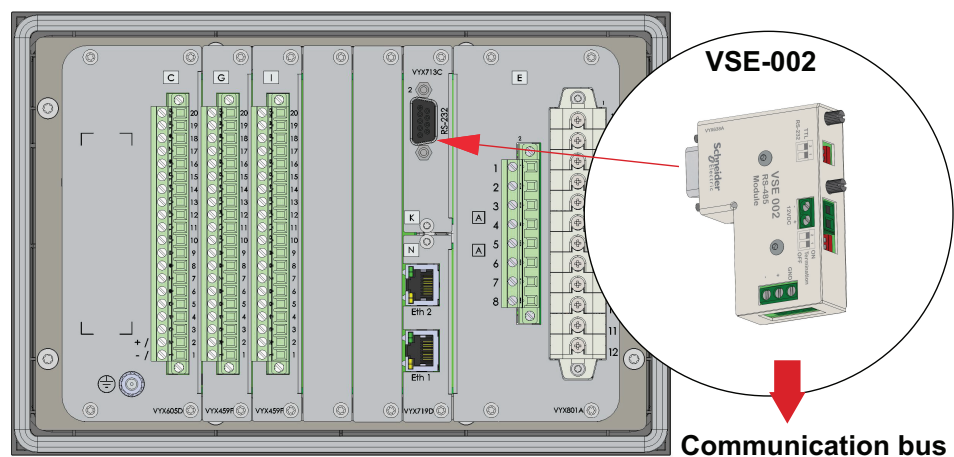

Figure 10.10: The VSE-002 module brings a serial RS-485 interface to the relay. The module is connected to the RS-232 serial port.



### Module interface to the relay

The physical interface of the VSE-002 is a 9-pin D-connector. The signal level is RS-232 and therefore, the interface type for the module has to be selected as **RS-232**.

It is possible to connect multiple relays in daisychain. “Termination” has to be selected as **on** for the last unit in the chain. The same applies when only one unit is used.

VSE-002 operates with the relay in RS-232 mode. Therefore the “interface type” has to be selected as RS-232.

Pin number	TTL mode	RS-232 mode
1	-	-
2	RXD (in)	RXD (in)
3	TXD (out)	TXD (out)
4	RTS (in)	RTS (in)
5		
6		
7	GND	GND
8		
9	+8V (in)	+8V (in)

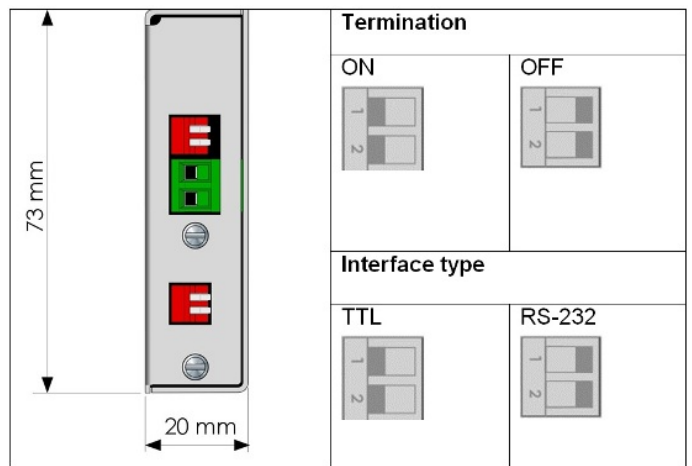

10.5.8.3 VSE-009 DeviceNet interface module

**⚠ DANGER**

**HAZARD OF ELECTRIC SHOCK, EXPLOSION, OR ARC FLASH**

- This equipment must only be installed or serviced by qualified electrical personnel.
- Turn off all power supplying this device and the equipment in which it is installed before working on the device or equipment.
- Connect protective ground (earth) before turning on any power supplying this device.

**Failure to follow these instructions will result in death or serious injury.**

VSE-009 (VSE009) is a DeviceNet interface module for the Easergy P3M30 and P3M32. The relay can be connected to the network using DeviceNet as the protocol. VSE-009 is attached to the RS-232 D-connector at the back of the relay. With the DeviceNet interface module, the following protocols can be used:

- None
- DeviceNet

An external +24VDC power supply interface is required.

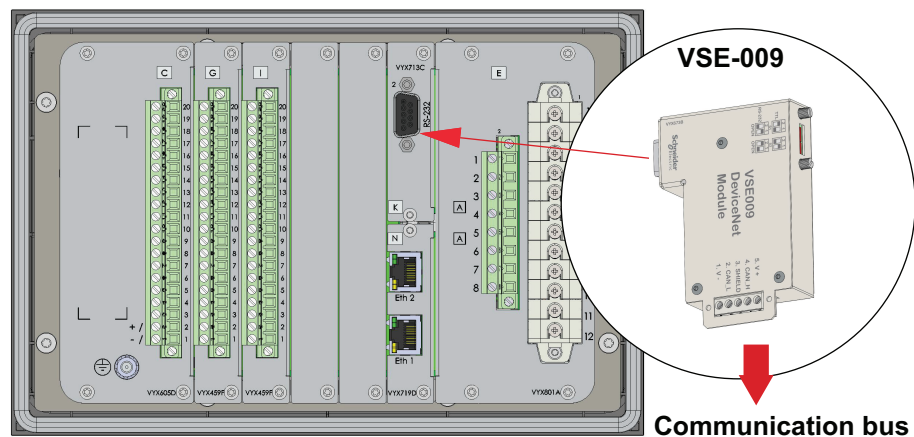

Figure 10.11: The VSE-009 module brings DeviceNet interface to the relay. The module is connected to the RS-232 serial port.

## 10.5.8.4

## VPA-3CG profibus interface module

**⚠ DANGER****HAZARD OF ELECTRIC SHOCK, EXPLOSION, OR ARC FLASH**

- This equipment must only be installed or serviced by qualified electrical personnel.
- Turn off all power supplying this device and the equipment in which it is installed before working on the device or equipment.
- Connect protective ground (earth) before turning on any power supplying this device.

**Failure to follow these instructions will result in death or serious injury.**

Easergy P3M30 and P3M32 can be connected to Profibus DP by using an external profibus interface module VPA-3CG (VPA3CG). The relay can then be monitored from the host system. VPA-3CG is attached to the RS-232 D-connector at the back of the relay with a VX-072 (VX072) cable. With the profibus interface module, the following protocols can be used:

- None
- ProfibusDP

The power for the module is taken from an external power supply interface.

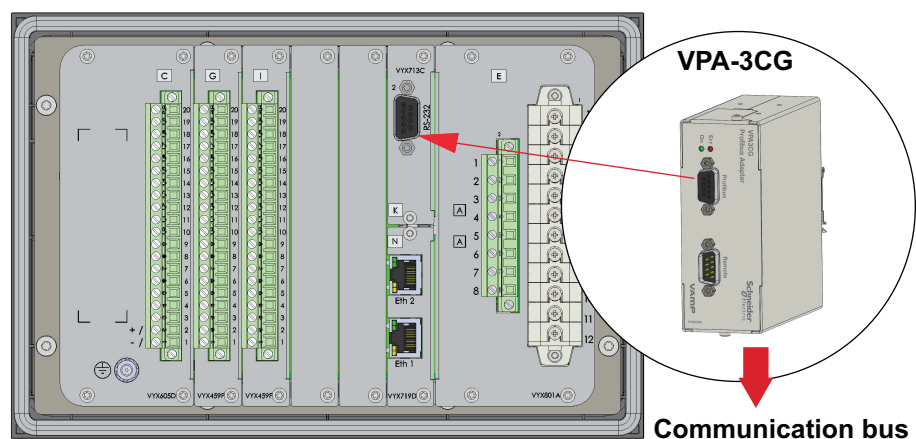

Figure 10.12: VPA-3CG module brings a profibus interface to the relay. The module is connected to the RS-232 serial port via a VX-072 cable.

**Module interface to the relay**

The physical interface of the VPA-3CG profibus interface module is a 9-pin D-connector.

Profibus devices are connected in a bus structure. Up to 32 stations (master or slave) can be connected in one segment. The bus is terminated by an active bus terminator at the beginning and end of each segments. When more than 32 stations are used, repeaters (line amplifiers) must be used to connect the individual bus segments. The maximum cable length depends on the transmission speed and cable type. The specified cable length can be increased by the use of repeaters. The use of more than 3 repeaters in a series is not recommended.

A separate product manual for VPA-3CG can be found on our website.

#### **10.5.8.5**

#### **VIO 12A RTD and analog input / output modules**

VIO 12A I/O modules can be connected to Easergy P3M30 and P3M32 using VSE 001 or VSE 002 interface modules.

A separate product manual for VIO 12A is available.

### 10.5.9 Block diagrams

The status of the output contacts is shown when the relay is energized but none of the protection, controlling or self-supervision elements are activated.

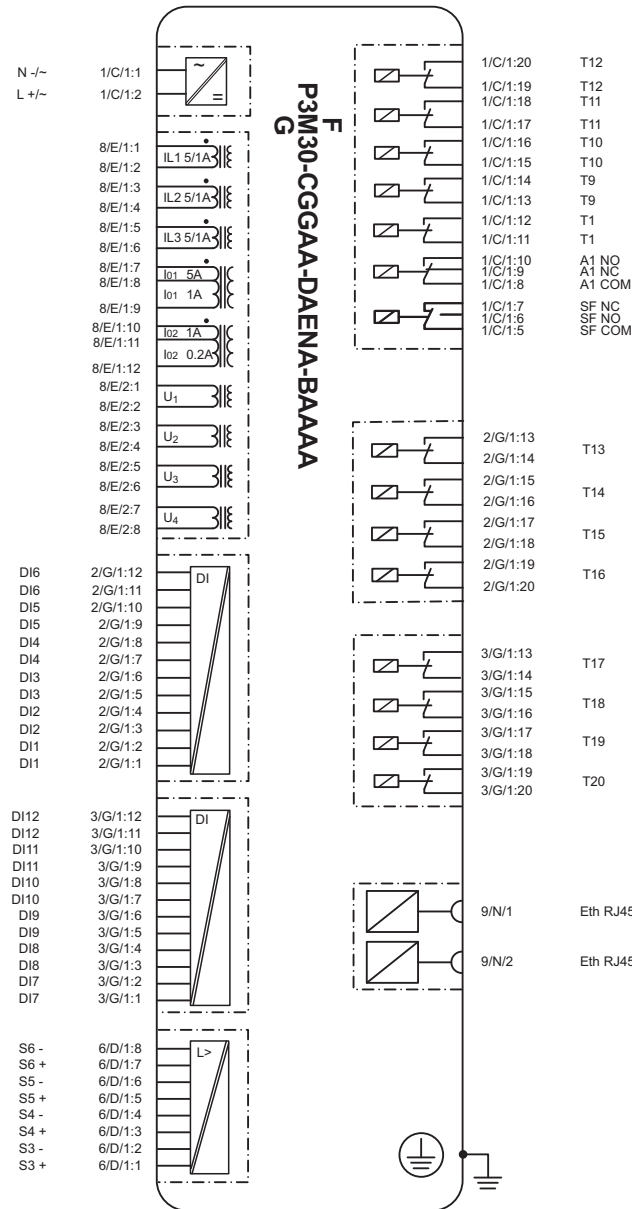

Figure 10.13: Typical block diagram for P3F30, P3M30 and P3G30 relays

**⚠ DANGER**

**HAZARD OF ELECTRIC SHOCK, EXPLOSION, OR ARC FLASH**

Connect the relay's protective ground to functional earth according to the connection diagrams presented in this document.

**Failure to follow this instruction will result in death or serious injury.**

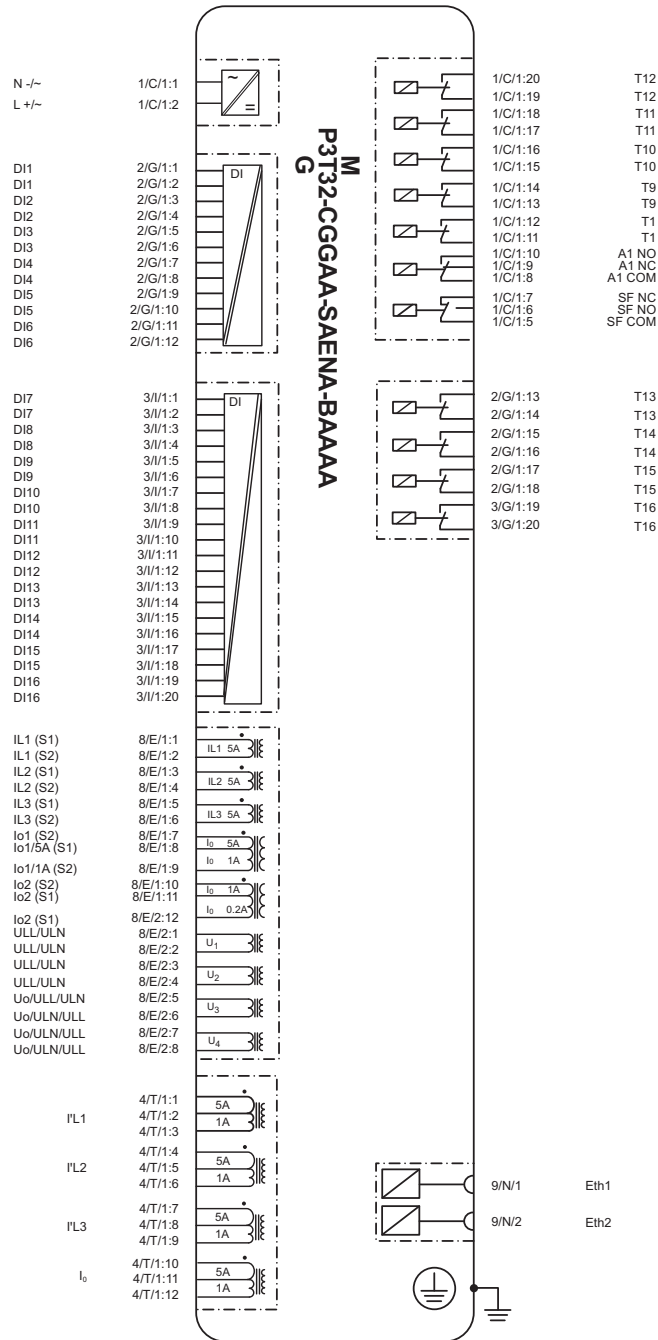

Figure 10.14: Typical block diagram for P3M32, P3T32 and P3G32 relays

**⚠ DANGER**

**HAZARD OF ELECTRIC SHOCK, EXPLOSION, OR ARC FLASH**

Connect the relay's protective ground to functional earth according to the connection diagrams presented in this document.

**Failure to follow this instruction will result in death or serious injury.**

### 10.5.10 Connection examples

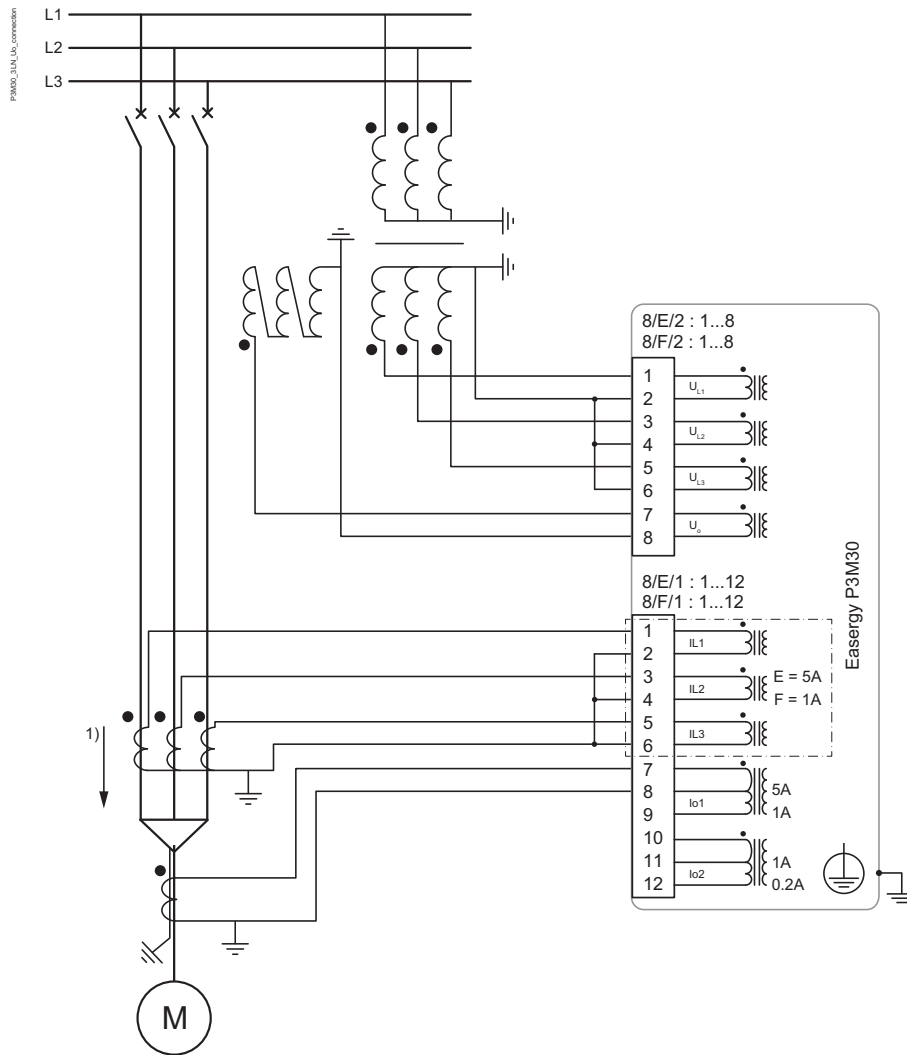

1) Positive current and exported energy direction

Figure 10.15: P3M30 connection for motor protection

## ⚠ DANGER

### HAZARD OF ELECTRIC SHOCK, EXPLOSION, OR ARC FLASH

- Always connect the polarity of the current transformer (CT) and / or the voltage transformer (VT) and their secondary ground wiring according to the connection diagrams presented in this document.
- Connect the relay's protective ground to functional earth according to the connection diagrams presented in this document.

**Failure to follow this instruction will result in death or serious injury.**

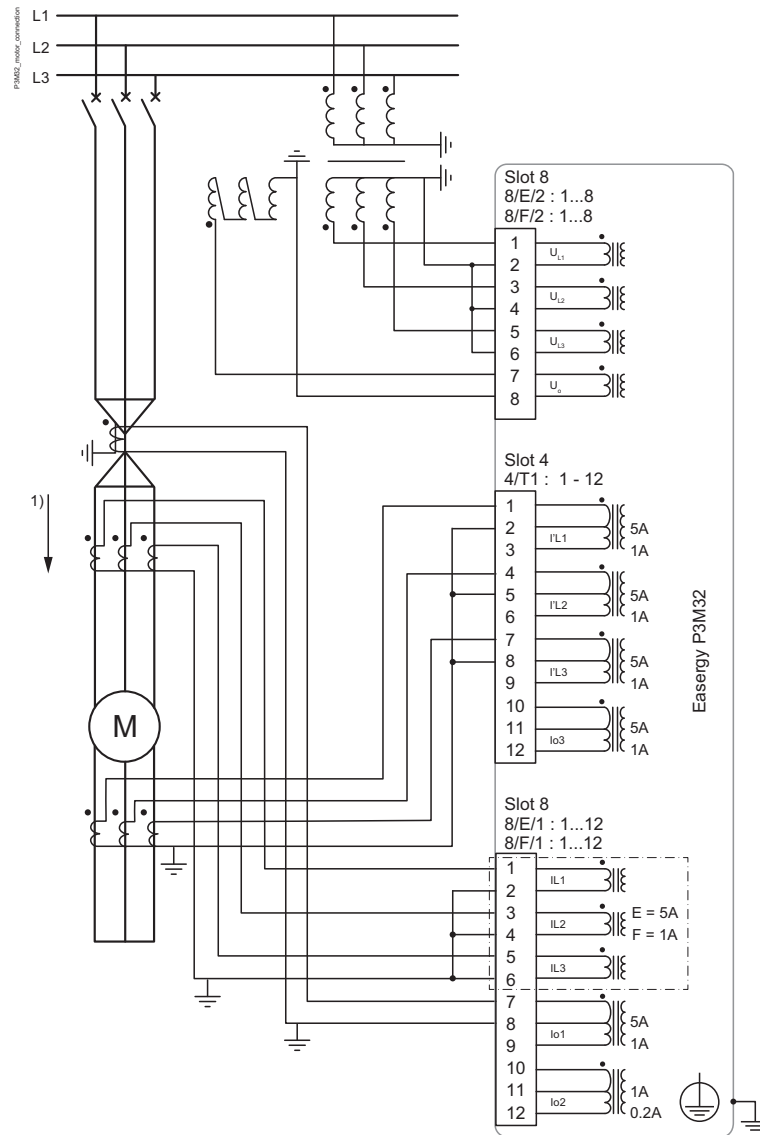

1) Positive current and exported energy direction

Figure 10.16: P3M32 connection for motor differential application

## ⚠ DANGER

### HAZARD OF ELECTRIC SHOCK, EXPLOSION, OR ARC FLASH

- Always connect the polarity of the current transformer (CT) and / or the voltage transformer (VT) and their secondary ground wiring according to the connection diagrams presented in this document.
- Connect the relay's protective ground to functional earth according to the connection diagrams presented in this document.

**Failure to follow this instruction will result in death or serious injury.**



# 10.6 Voltage measurement modes

Depending on the application and available voltage transformers, the relay can be connected either to zero-sequence voltage, line-to-line voltage or line-to-neutral voltage. The configuration parameter "Voltage measurement mode" must be set according to the type of connection used.

## Voltage measuring modes correlation for E and F analogue measurement cards

U1, U2, U3 and U4 are voltage channels for the relay.

The physical voltage transformer connection in the Easergy P3M30 and P3M32 depends on the used voltage transformer connection mode. This setting is defined in the scalings setting view. See Table 10.30.

**Table 10.30: Correlation between voltage measuring mode and physical voltage input in Terminals 8/E/1 and 8/F/2**

Terminal	8/E/2 and 8/F/2							
	1	2	3	4	5	6	7	8
<b>Voltage channel</b>	<b>U1</b>		<b>U2</b>		<b>U3</b>		<b>U4</b>	
<b>Mode / Used voltage</b>								
3LN	UL1		UL2		UL3		Not in use	
3LN+U <sub>0</sub>							U <sub>0</sub>	
3LN+LLy							LLy	
3LN+LNy							LNy	
2LL+U <sub>0</sub>	U12		U23		U <sub>0</sub>		Not in use	
2LL+U <sub>0</sub> +LLy							LLy	
2LL+U <sub>0</sub> +LNy							LNy	
LL+LLy+U <sub>0</sub> +LLz							U12z	
LN+LNy+U <sub>0</sub> +LNz	UL1	UL1y					UL1z	

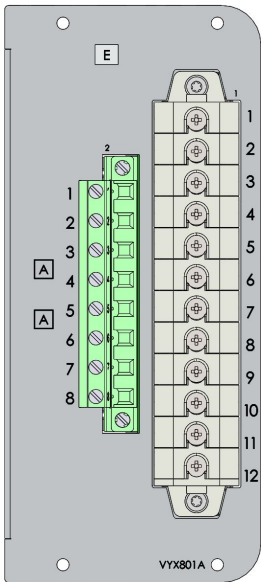

Figure 10.17: Example of Terminal 8/E/1 and 8/E/2

## 10.6.1 Multiple channel voltage measurement

The slot 8 can accommodate four different analogue measurement cards. Each of them have four voltage measurement channels.

This section introduces various voltage connections and the required voltage measuring modes for the connections. The settings are defined in the **Scalings** view.

**3LN**

- Voltages measured by VTs:  $U_{L1}$ ,  $U_{L2}$ ,  $U_{L3}$
- Values calculated:  $U_{L12}$ ,  $U_{L23}$ ,  $U_{L31}$ ,  $U_1$ ,  $U_2$ ,  $U_2/U_1$ ,  $f$ ,  $U_0$
- Measurements available: All
- Protection functions not available: ANSI 25

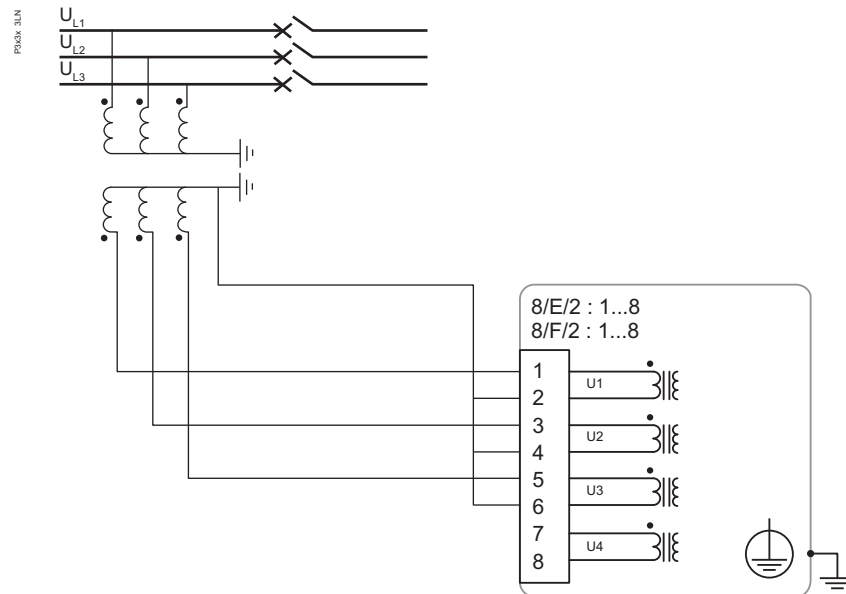
**⚠ DANGER****HAZARD OF ELECTRIC SHOCK, EXPLOSION, OR ARC FLASH**

- Always connect the polarity of the current transformer (CT) and / or the voltage transformer (VT) and their secondary ground wiring according to the connection diagrams presented in this document.
- Connect the relay's protective ground to functional earth according to the connection diagrams presented in this document.

**Failure to follow this instruction will result in death or serious injury.**

**3LN+U<sub>0</sub>**

This connection is typically used for feeder and motor protection schemes.

- Voltages measured by VTs:  $U_{L1}$ ,  $U_{L2}$ ,  $U_{L3}$ ,  $U_0$
- Values calculated:  $U_{L12}$ ,  $U_{L23}$ ,  $U_{L31}$ ,  $U_1$ ,  $U_2$ ,  $U_2/U_1$ ,  $f$
- Measurements available: All
- Protection functions not available: ANSI 25

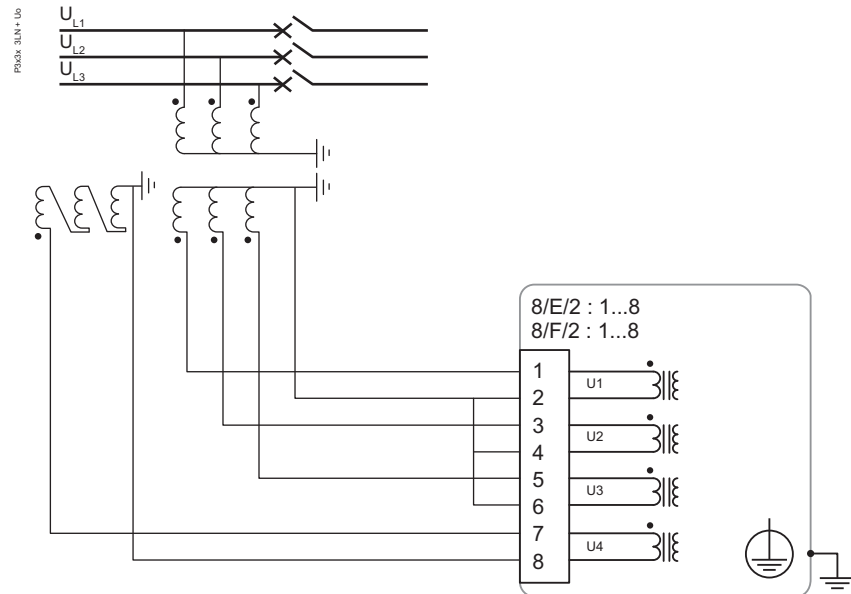
**⚠ DANGER****HAZARD OF ELECTRIC SHOCK, EXPLOSION, OR ARC FLASH**

- Always connect the polarity of the current transformer (CT) and / or the voltage transformer (VT) and their secondary ground wiring according to the connection diagrams presented in this document.
- Connect the relay's protective ground to functional earth according to the connection diagrams presented in this document.

**Failure to follow this instruction will result in death or serious injury.**

### 3LN+LLy

#### Voltage measuring mode: 3LN+LLy

Connection of voltage transformers for synchrocheck application. The other side of the CB has line-to-line connection for reference voltage.

- Voltages measured by VTs:  $U_{L1}$ ,  $U_{L2}$ ,  $U_{L3}$ ,  $U_{L12y}$
- Values calculated:  $U_{L12}$ ,  $U_{L23}$ ,  $U_{L31}$ ,  $U_1$ ,  $U_2$ ,  $U_2/U_1$ ,  $f$ ,  $U_0$
- Measurements available: All
- Protection functions not available: -

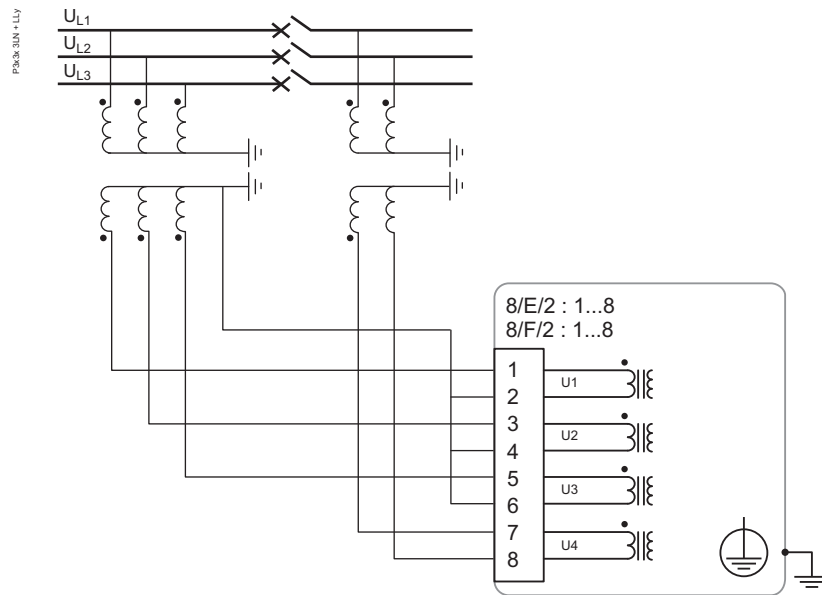

## **⚠ DANGER**

### **HAZARD OF ELECTRIC SHOCK, EXPLOSION, OR ARC FLASH**

- Always connect the polarity of the current transformer (CT) and / or the voltage transformer (VT) and their secondary ground wiring according to the connection diagrams presented in this document.
- Connect the relay's protective ground to functional earth according to the connection diagrams presented in this document.

**Failure to follow this instruction will result in death or serious injury.**

### 3LN+LNy

#### Voltage measuring mode: 3LN+LNy

This connection is typically used for feeder protection scheme where line-to-neutral voltage is required for synchrocheck application.

- Voltages measured by VTs:  $U_{L1}$ ,  $U_{L2}$ ,  $U_{L3}$ ,  $U_{L1y}$
- Values calculated:  $U_{L12}$ ,  $U_{L23}$ ,  $U_{L31}$ ,  $U_1$ ,  $U_2$ ,  $U_2/U_1$ ,  $f$ ,  $U_0$
- Measurements available: All
- Protection functions not available: -

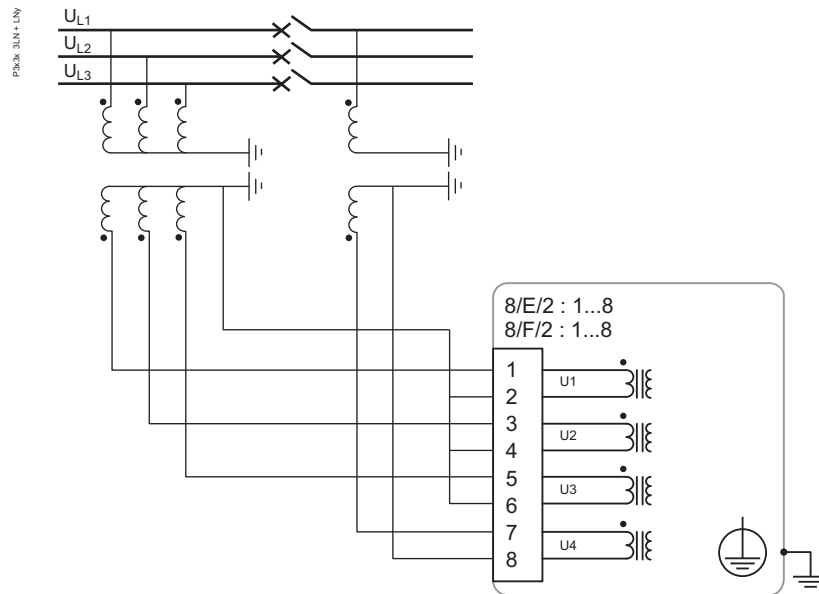

## **⚠ DANGER**

### **HAZARD OF ELECTRIC SHOCK, EXPLOSION, OR ARC FLASH**

- Always connect the polarity of the current transformer (CT) and / or the voltage transformer (VT) and their secondary ground wiring according to the connection diagrams presented in this document.
- Connect the relay's protective ground to functional earth according to the connection diagrams presented in this document.

**Failure to follow this instruction will result in death or serious injury.**

**2LL+U<sub>0</sub>**

Connection of two line-to-line and neutral displacement voltage measurement schemes.

- Voltages measured by VTs:  $U_{L12}$ ,  $U_{L23}$ ,  $U_0$
- Values calculated:  $U_{L31}$ ,  $U_{L1}$ ,  $U_{L2}$ ,  $U_{L3}$ ,  $U_1$ ,  $U_2$ ,  $U_2/U_1$ ,  $f$
- Measurements available: All
- Protection functions not available: ANSI 25

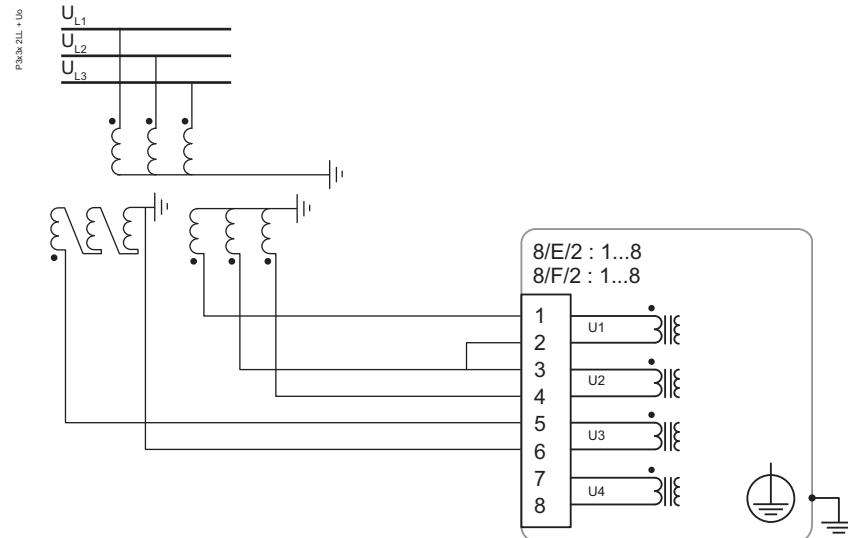

## ⚠ DANGER

### HAZARD OF ELECTRIC SHOCK, EXPLOSION, OR ARC FLASH

- Always connect the polarity of the current transformer (CT) and / or the voltage transformer (VT) and their secondary ground wiring according to the connection diagrams presented in this document.
- Connect the relay's protective ground to functional earth according to the connection diagrams presented in this document.

**Failure to follow this instruction will result in death or serious injury.**

### 2LL+U<sub>0</sub>+LLy

Connection of two line-to-line and neutral displacement voltage schemes. Line-to-line reference voltage is taken from the other side of the CB for synchrocheck scheme.

- Voltages measured by VTs: U<sub>L12</sub>, U<sub>L23</sub>, U<sub>0</sub>, U<sub>L12y</sub>
- Values calculated: U<sub>L31</sub>, U<sub>L1</sub>, U<sub>L2</sub>, U<sub>L3</sub>, U<sub>1</sub>, U<sub>2</sub>, U<sub>2/U1</sub>, f
- Measurements available: All
- Protection functions not available: -

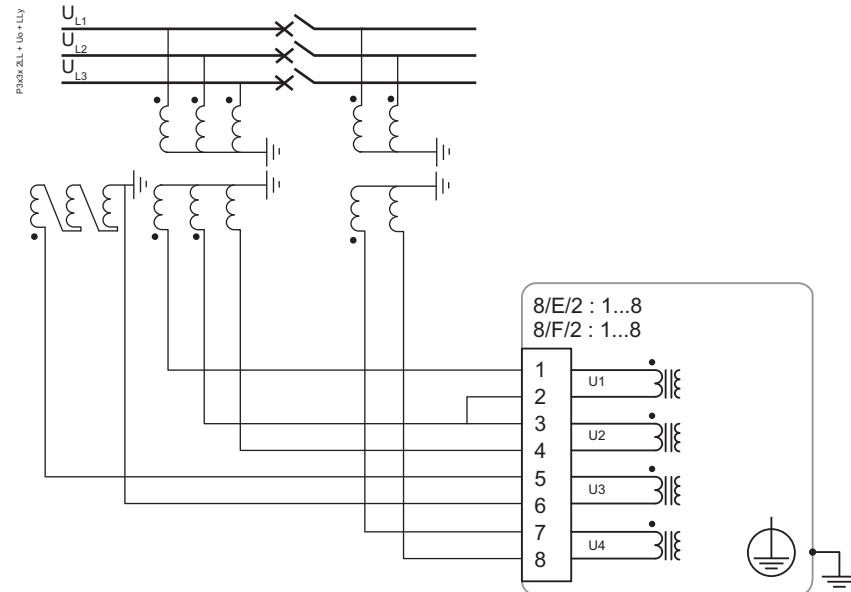

## **⚠ DANGER**

### **HAZARD OF ELECTRIC SHOCK, EXPLOSION, OR ARC FLASH**

- Always connect the polarity of the current transformer (CT) and / or the voltage transformer (VT) and their secondary ground wiring according to the connection diagrams presented in this document.
- Connect the relay's protective ground to functional earth according to the connection diagrams presented in this document.

**Failure to follow this instruction will result in death or serious injury.**

**2LL+U<sub>0</sub>+LNy**

Connection of two line-to-line and neutral displacement voltage schemes. The other side of the CB has phase-to-neutral connection for synchrocheck.

- Voltages measured by VTs: U<sub>L12</sub>, U<sub>L23</sub>, U<sub>0</sub>, U<sub>L1y</sub>
- Values calculated: U<sub>L31</sub>, U<sub>L1</sub>, U<sub>L2</sub>, U<sub>L3</sub>, U<sub>1</sub>, U<sub>2</sub>, U<sub>2/U1</sub>, f
- Measurements available: All
- Protection functions not available: -

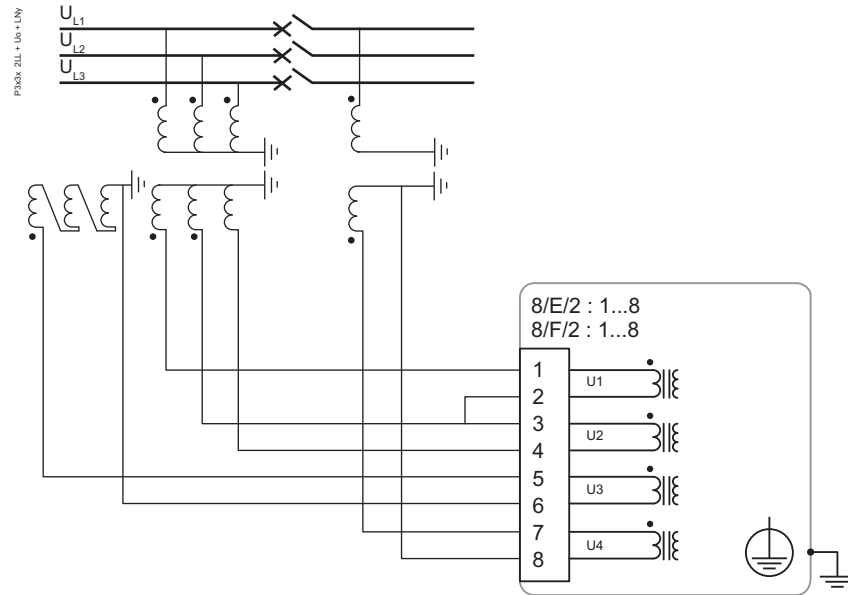

**⚠ DANGER**

**HAZARD OF ELECTRIC SHOCK, EXPLOSION, OR ARC FLASH**

- Always connect the polarity of the current transformer (CT) and / or the voltage transformer (VT) and their secondary ground wiring according to the connection diagrams presented in this document.
- Connect the relay's protective ground to functional earth according to the connection diagrams presented in this document.

**Failure to follow this instruction will result in death or serious injury.**



### LL+U<sub>0</sub>+LLy+LLz

This scheme has two CBs to be synchronized. The left side of the bus bar has line-to-line and the right side line-to-line connection for synchrocheck's reference voltages. In the middle, the system voltages are measured by phase-to-neutral and open delta connection.

- Voltages measured by VTs: U<sub>L12</sub>, U<sub>0</sub>, U<sub>L12y</sub>, U<sub>L12z</sub>
- Values calculated: U<sub>L1</sub>, U<sub>L2</sub>, U<sub>L3</sub>, f
- Measurements available: -
- Protection functions not available: ANSI 67

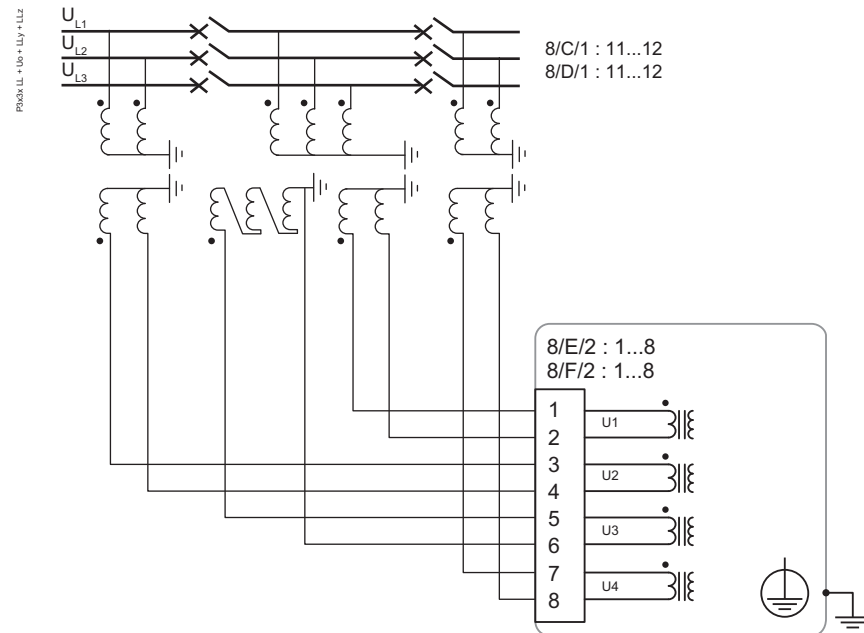

## **⚠ DANGER**

### **HAZARD OF ELECTRIC SHOCK, EXPLOSION, OR ARC FLASH**

- Always connect the polarity of the current transformer (CT) and / or the voltage transformer (VT) and their secondary ground wiring according to the connection diagrams presented in this document.
- Connect the relay's protective ground to functional earth according to the connection diagrams presented in this document.

**Failure to follow this instruction will result in death or serious injury.**

### LN+U<sub>0</sub>+LNY+LNz

This scheme has two CBs to be synchronized. The left and right sides of the bus bar have line-to-neutral connections for synchrocheck's reference voltages. In the middle, system voltages are measured by phase-to-neutral and broken delta connection.

- Voltages measured by VTs:  $U_L+U_0+U_{LY}+U_{LZ}$
- Values calculated:  $U_{L12}$ ,  $U_{L23}$ ,  $U_{L31}$ ,  $f$
- Measurements available: -
- Protection functions not available: ANSI 67

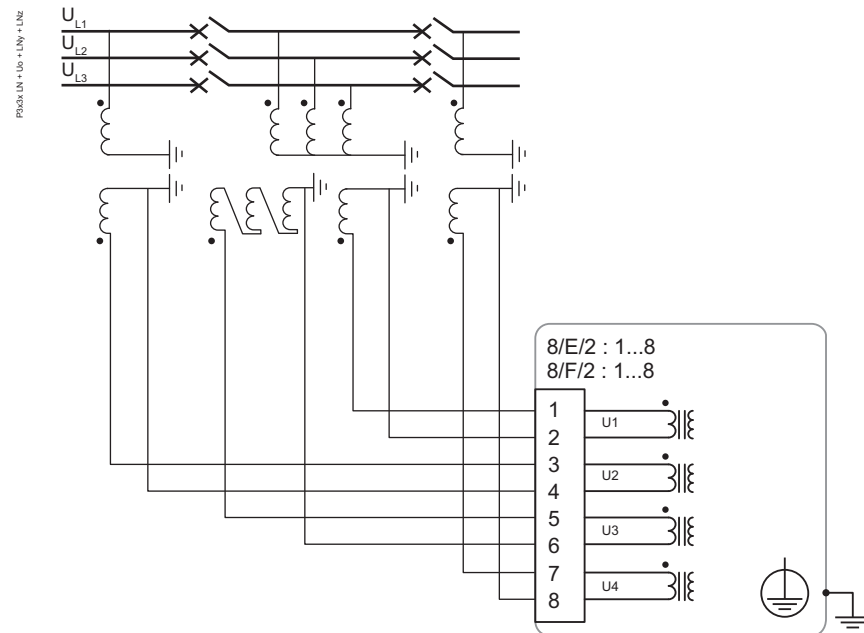

## **⚠ DANGER**

### **HAZARD OF ELECTRIC SHOCK, EXPLOSION, OR ARC FLASH**

- Always connect the polarity of the current transformer (CT) and / or the voltage transformer (VT) and their secondary ground wiring according to the connection diagrams presented in this document.
- Connect the relay's protective ground to functional earth according to the connection diagrams presented in this document.

**Failure to follow this instruction will result in death or serious injury.**

# 10.7 CSH120 and CSH200 Core balance CTs

## Function

The specifically designed CSH120 and CSH200 core balance CTs are for direct earth fault overcurrent measurement. The difference between CSH120 and CSH200 is the inner diameter.

Due to their low voltage insulation, they can only be used on cables.

## Characteristics



Figure 10.18: CSH120 and CSH200 core balance CTs.

	CSH120	CSH200
Inner diameter	120 mm (4.7 in)	200 mm (7.9 in)
Weight	0.6 kg (1.32 lb)	1.4 kg (3.09 lb)
Accuracy	±5% at 20°C (68°F) ±6% max. from -25°C to 70°C (-13°F to +158°F)	
Transformation ratio	1/470	
Maximum permissible current	20 kA - 1 s	
Operating temperature	-25°C to +70°C (-13°F to +158°F)	
Storage temperature	-40°C to +85°C (-40°F to +185°F)	

## Dimensions

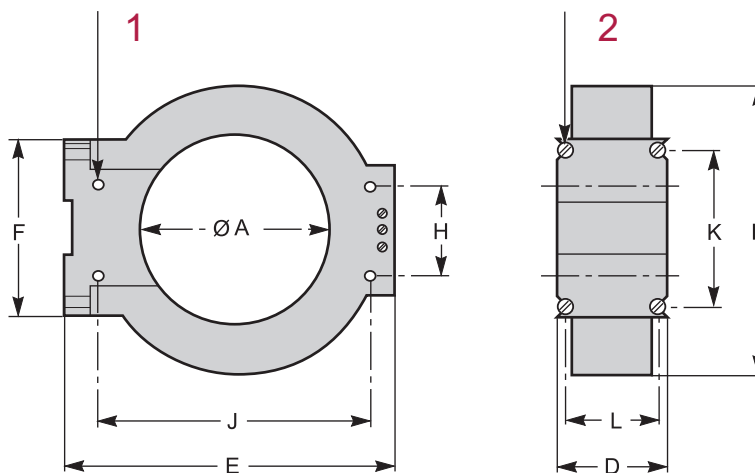

(1): 4 horizontal mounting holes Ø 6

(2): 4 vertical mounting holes Ø 6

Dimensions	A	B	D	E	F	H	J	K	L
CSH120 (in)	120 (4.75)	164 (6.46)	44 (1.73)	190 (7.48)	80 (3.14)	40 (1.57)	166 (6.54)	65 (2.56)	35 (1.38)
CSH200 (in)	196 (7.72)	256 (10.1)	46 (1.81)	274 (10.8)	120 (4.72)	60 (2.36)	254 (10)	104 (4.09)	37 (1.46)

**⚠ DANGER****HAZARD OF ELECTRIC SHOCK, ELECTRIC ARC OR BURNS**

- Only qualified personnel should install this equipment. Such work should be performed only after reading this entire set of instructions and checking the technical characteristics of the device.
- NEVER work alone.
- Turn off all power supplying this equipment before working on or inside it. Consider all sources of power, including the possibility of backfeeding.
- Always use a properly rated voltage sensing device to confirm that all power is off.
- Only CSH120 and CSH200 core balance CTs can be used for direct earth fault overcurrent measurement.
- Install the core balance CTs on insulated cables.
- Cables with a rated voltage of more than 1000 V must also have an earthed shielding.

**Failure to follow these instructions will result in death or serious injury.**

**Assembly**

Group the MV cable (or cables) in the middle of the core balance CT.

Use non-conductive binding to hold the cables.

Remember to insert the 3 medium voltage cable shielding earthing cables through the core balance CT.

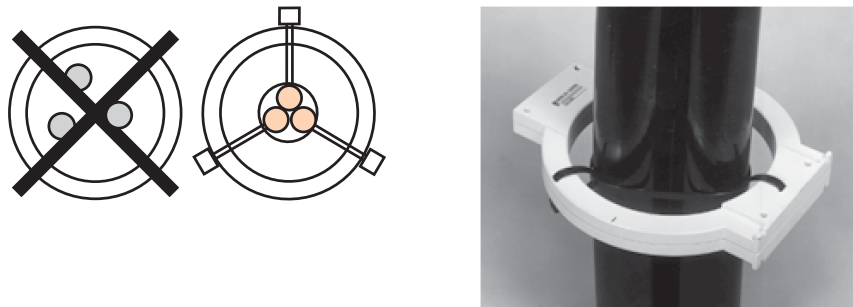

Figure 10.19: Assembly on MV cables

## ⚠ CAUTION

### HAZARD OF NON-OPERATION

Connect the secondary circuit and the cable shielding of the CSH core balance CTs to earth in the shortest possible manner according to the connection diagram presented in this document.

**Failure to follow these instructions can result in equipment damage.**

### Connection

Connection to Easergy P3M30 and P3M32

To earth fault current  $I_0$  input, on connector X1, terminals 9 and 10 (shielding).

### Recommended cable

- Sheathed cable, shielded by tinned copper braid
- Minimum cable cross-section 0.93 mm<sup>2</sup> (AWG 18)
- Resistance per unit length < 100 mΩ/m (30.5 mΩ/ft)
- Minimum dielectric strength: 1000 V (700 Vrms)
- Connect the cable shielding in the shortest manner possible to Easergy P3M30 and P3M32
- Flatten the connection cable against the metal frames of the cubicle.

The connection cable shielding is grounded in Easergy P3M30 and P3M32.

The maximum resistance of the Easergy P3M30 and P3M32 connection wiring must not exceed 4 Ω (i.e. 20 m maximum for 100 mΩ/m or 66 ft maximum for 30.5 mΩ/ft).

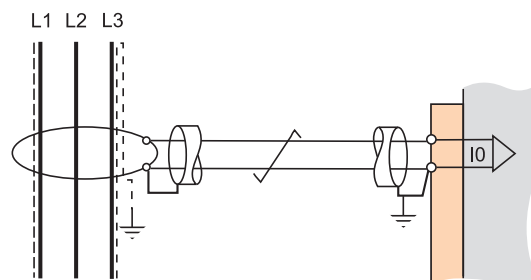

# 11 Test and environmental conditions

**Table 11.1: Disturbance tests**

Test	Standard & Test class / level	Test value
<b>Emission</b>	<b>IEC/EN 60255-26 (ed3)</b>	
Conducted	EN 55022, Class A / IEC 60255-25 / CISPR 22	0.15 – 30 MHz
Emitted	EN 55011, Class A / IEC 60255-25 / CISPR 11	30 – 1000 MHz
<b>Immunity</b>	<b>IEC/EN 60255-26 (ed3)</b>	
1 Mhz damped oscillatory wave	IEC/EN 61000-4-18, IEC 60255-22-1	±2.5kVp CM ±2.5kVp DM
Static discharge (ESD)	IEC/EN 61000-4-2 Level 4, IEC 60255-22-2	±8 kV contact ±15 kV air
Emitted HF field	IEC/EN 61000-4-3 Level 3, IEC 60255-22-3	80 - 2700 MHz, 10 V/m
Fast transients (EFT)	IEC/EN 61000-4-4 Level 4, IEC 60255-22-4	±4 kV, 5/50 ns, 5 kHz
Surge	IEC/EN 61000-4-5 Level 4, IEC 60255-22-5	±4 kV, 1.2/50 µs, CM ±2 kV, 1.2/50 µs, DM
Conducted HF field	IEC/EN 61000-4-6 Level 3, IEC 60255-22-6	0.15 - 80 MHz, 10 Vrms
Power-frequency magnetic field	IEC/EN 61000-4-8	300A/m (continuous) 1000A/m 1 – 3s
Pulse magnetic field	IEC/EN 61000-4-9 Level 5	1000A/m, 1.2/50 µs
ac and dc voltage dips	IEC/EN 61000-4-29, IEC/EN 61000-4-11	0% of rated voltage - Criteria A <ul style="list-style-type: none"> <li>ac: ≥ 0.5 cycle</li> <li>dc: ≥ 10 ms</li> </ul> 40% of rated voltage - Criteria C <ul style="list-style-type: none"> <li>ac: 10 cycles</li> <li>dc: 200 ms</li> </ul> 70% of rated voltage - Criteria C <ul style="list-style-type: none"> <li>ac: 25 cycles</li> <li>dc: 500 ms</li> </ul>
ac and dc voltage interruptions	IEC/EN 61000-4-29, IEC/EN 61000-4-11	100% interruption - Criteria C <ul style="list-style-type: none"> <li>ac: 250 cycles</li> <li>dc: 5 s</li> </ul>
Voltage alternative component	IEC/EN 61000-4-17	15% of operating voltage (dc) / 10min

**Table 11.2: Electrical safety tests**

Test	Standard & Test class / level	Test value
Impulse voltage withstand	IEC/EN 60255-27, EN 60255-5, Class III	5 kV, 1.2/50 $\mu$ s, 0.5 J 1 kV, 1.2/50 $\mu$ s, 0.5 J Communication
Dielectric test	IEC/EN 60255-27, EN 60255-5, Class III	2 kV, 50 Hz 0.5 kV, 50 Hz Communication
Insulation resistance	IEC/EN 60255-27, EN 60255-5	
Protective bonding resistance	IEC/EN 60255-27	
Clearance and creepage distance	Design criteria for distances as per IEC 60255-27 Annex C (pollution degree 2, overvoltage category 3)	
Power supply burden	IEC 60255-1	

**Table 11.3: Mechanical tests**

Test	Standard & Test class / level	Test value
<b>Device in operation</b>		
Vibrations	IEC 60255-21-1, Class II / IEC 60068-2-6, Fc	1 Gn, 10 Hz – 150 Hz
Shocks	IEC 60255-21-2, Class II / IEC 60068-2-27, Ea	10 Gn / 11 ms
Seismic	IEC 60255-21-3 Method A, Class II	2G horizontal / 1G vertical, 1–35 Hz
<b>Device de-energized</b>		
Vibrations	IEC 60255-21-1, Class II / IEC 60068-2-6, Fc	2 Gn, 10 Hz – 150 Hz
Shocks	IEC 60255-21-2, Class II / IEC 60068-2-27, Ea	30 Gn / 11 ms
Bump	IEC 60255-21-2, Class II / IEC 60068-2-27, Ea	20 Gn / 16 ms

**Table 11.4: Environmental tests**

Test	Standard & Test class / level	Test value
<b>Device in operation</b>		
Dry heat	EN / IEC 60068-2-2, Bd	70°C (158°F)
Cold	EN / IEC 60068-2-1, Ad	-40°C (-40°F)
Damp heat, cyclic	EN / IEC 60068-2-30, Db	From 25°C (77°F) to 55°C (131°F) From 93% RH to 98% RH Testing duration: 6 days
Damp heat, static	EN / IEC 60068-2-78, Cab	40°C (104°F) 93% RH Testing duration: 10 days
Change of temperature	IEC / EN 60068-2-14, Nb	<ul style="list-style-type: none"> <li>Lower temp -40°C</li> <li>Upper temp 70°C</li> <li>5 cycles</li> </ul>
Flowing mixed gas corrosion test, method 1	IEC 60068-2-60, Ke	25° C (77° F), 75 % RH, 21 days 100 ppb H <sub>2</sub> S, 500 ppb SO <sub>2</sub>
Flowing mixed gas corrosion test, method 4	IEC 60068-2-60, Ke	25° C (77° F), 75 % RH, 21 days 10 ppb H <sub>2</sub> S, 200 ppb NO <sub>2</sub> , 10 ppb CL <sub>2</sub> , 200 ppb SO <sub>2</sub>
<b>Device in storage</b>		
Dry heat	EN / IEC 60068-2-2, Bb	70°C (158°F)
Cold	EN / IEC 60068-2-1, Ab	-40°C (-40°F)

**Table 11.5: Environmental conditions**

Ambient temperature, in-service * **	-40 – 60°C (-40 – 140°F)***
Ambient temperature, storage	-40 – 70°C (-40 – 158°F)
Relative air humidity	< 95%, no condensation allowed
Maximum operating altitude	2000 m (6561.68 ft)

\*) The display contrast is affected by ambient temperatures below -25°C (-13°F).

\*\*) After a cold start, in temperatures below -30°C (-22°F), allow the relay to stabilize for a few minutes to achieve the specified accuracy.

\*\*\*)Recommended values with VYX 695 projection mounting frame:

- Easergy P3M30 and P3M32 with 1 x raising frame → maximum ambient temperature 55°C
- Easergy P3M30 and P3M32 with 2 x raising frame → maximum ambient temperature 50°C

**Table 11.6: Casing**

Degree of protection (IEC 60529)	IP54 Front panel, IP20 rear side
Dimensions (W x H x D)	270 x 176 x 230 mm / 10.63 x 6.93 x 9.06 in
Weight	4.2 kg (9.272 lb) or higher (depends of options)



# 12 Maintenance

## **⚠ DANGER**

### **HAZARD OF ELECTRIC SHOCK, EXPLOSION, OR ARC FLASH**

- Wear your personal protective equipment (PPE) and comply with the safe electrical work practices. For clothing refer applicable local standards.
- Only qualified personnel should install this equipment. Such work should be performed only after reading this entire set of instructions and checking the technical characteristics of the device.
- NEVER work alone.
- Turn off all power supplying this equipment before working on or inside it. Consider all sources of power, including the possibility of backfeeding.
- Always use a properly rated voltage sensing device to ensure that all power is off.
- Do not open the secondary circuit of a live current transformer.
- Always connect the polarity of the current transformer (CT) and the voltage transformer (VT) and their secondary ground wiring according to the connection diagrams presented in this document.
- Connect the relay's protective ground to functional earth according to the connection diagrams presented in this document.

**Failure to follow this instruction will result in death or serious injury.**

The Easergy P3 protection relays and arc flash protection products together with their extension units, communication accessories, arc flash detection sensors and cabling, later called “device”, require maintenance in work according to their specification. Keep a record of the maintenance actions. The maintenance can include, but is not limited to, the following actions.

---

## 12.1 Preventative maintenance

Check the device visually when the switchgear is de-energized. During the inspection, pay attention to:

- dirty components
- loose wire connections
- damaged wiring
- indicator lights (see section LED test sequence)
- other mechanical connections

Perform visual inspection every three (3) years minimum.

## 12.2 Periodical testing

Test the device periodically according to the end user's safety instructions and national safety instructions or law. Carry out functional testing every five (5) years minimum.

Conduct the testing with a secondary injection principle for the protection stages used in the device and its extension units.

In corrosive or offshore environments, carry out functional testing every three (3) years. For the testing procedures, see separate testing manuals.

## 12.3 Hardware cleaning

Special attention must be paid that the device do not become dirty. If cleaning is required, wipe out dirt from the units.

## 12.4 Arc sensor condition and positioning check

After commissioning, sensor replacement, modification procedure, cleaning and periodical testing, always check that the sensor positioning remains as it was originally designed.

## 12.5 System status messages

If the device's self checking detects an unindented system status, it will in most cases provide an alarm by activating the service LED and indication status notification on the LCD screen. If this happens, store the possible message and contact your local representative for further guidance.

## 12.6 Spare parts

Use an entire unit as a spare part for the device to be replaced. Always store spare parts in storage areas that meet the requirements stated in the user documentation.

## 12.7 Self-supervision

### **NOTICE**

#### **LOSS OF PROTECTION OR RISK OF NUISANCE TRIPPING**

- If the relay is no longer supplied with power or is in permanent fault state, the protection functions are no longer active and all the Easergy P3 digital outputs are dropped out.
- Check that the operating mode and SF relay wiring are compatible with the installation.

**Failure to follow these instructions can result in equipment damage and unwanted shutdown of the electrical installation.**

#### **Description**

The electronic parts and the associated circuitry as well as the program execution are supervised by means of a separate watchdog circuit. Besides supervising the device, the watchdog circuit attempts to restart the microcontroller in an inoperable situation. If the microcontroller does not restart, the watchdog issues a self-supervision signal indicating a permanent internal condition.

When the watchdog circuit detects a permanent fault, it always blocks any control of other digital outputs (except for the self-supervision SF output). In addition, the internal supply voltages are supervised. Should the auxiliary supply of the device disappear, an indication is automatically given because the device status inoperative (SF) output functions on a working current principle. This means that the SF relay is energized, the 1/C/1:5–7 (or 1/D/1:5-7) contact closed, when the auxiliary supply is on and the Easergy P3M30 and P3M32 device is fully operational.

In addition to the dedicated self-supervision function, the protection relay has several alarm signals that can be connected to outputs through the output matrix. The alarms include:

- remote communication inactive
- extension I/O communication inactive
- communication Port 1 down
- communication Port 2 down
- selfdiag 1, 2 or 3 alarm

- password open

**NOTE:** SF output is referenced as "service status output" in the setting tool.

To get self-supervision alarms to SF output contact, they must be linked in the DIAGNOSIS setting view's section SELFDIAG SIGNAL CONFIGURATION. Required alarms are first linked to a Selfdiag1, Selfdiag2 or Selfdiag3 group (Figure 12.1).

SELFDIAG SIGNAL CONFIGURATION	
SecPulse	Selfdiag1
Relays	Selfdiag1
E2PROM	Selfdiag1
Stack usage	Selfdiag1
Memory check	Selfdiag1
Background task	Selfdiag1
Parameter range check	Selfdiag1
CPU load	Selfdiag1
Internal voltage +	Selfdiag1
Low auxiliary voltage	Selfdiag1
Internal temperature	Selfdiag1
ADC check 1	Selfdiag1
COM buffer	Selfdiag1
Slot card	Selfdiag1
Order code	Selfdiag1
FPGA version	Selfdiag2
FPGA configuration	Selfdiag2
Arc sensor	Selfdiag2
BI	Selfdiag2

Figure 12.1: Selfdiag alarm signal configuration

Having the Selfdiag alarm grouping made, the appropriate alarms can be assigned to SF relay. By default, selfdiag alarm 2 is linked to SF relay (Figure 12.2). The function of this default setup is the same as in the older systems where this configuration was not possible.

Link selfdiag 1 to SF relay

Link selfdiag 2 to SF relay

Link selfdiag 3 to SF relay

Figure 12.2: Linking Selfdiag alarm 1-3 to SF relay

It is possible to choose what selfdiag alarms 1-3 do when activated. This option can be done through the output matrix (Figure 12.3). This allows you to categorize and prioritize actions for each selfdiag alarms individually. For example, in this configuration, selfdiag alarm 3 activates VO6.

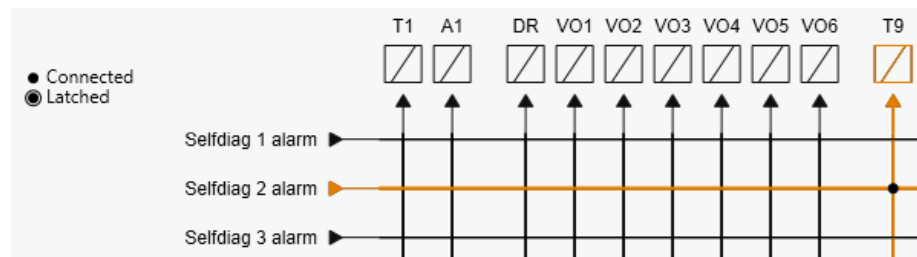

Figure 12.3: Selecting selfdiag 1-3 actions. The number of outputs varies depending on the device and order code.

## 12.7.1 Diagnostics

The device runs self-diagnostic tests for hardware and software in boot sequence and also performs runtime checking.

### Permanent inoperative state

If a permanent inoperative state has been detected, the device releases an SF relay contact and the status LED is set on. The local panel also displays a detected fault message. The permanent inoperative state is entered when the device is not able to handle main functions.

### Temporal inoperative state

When the self-diagnostic function detects a temporal inoperative state, a Selfdiag matrix signal is set and an event (E56) is generated. If the inoperative state was only temporary, an off event is generated (E57). The self-diagnostic state can be reset via the front panel.

### Diagnostic registers

There are four 16-bit diagnostic registers which are readable through remote protocols. Table 12.1 shows the meaning of each diagnostic register and their bits.

**Table 12.1: Readable registers through remote communication protocols**

Register	Bit	Code	Description
SelfDiag1	0 (LSB)	(Reserved)	(Reserved)
	1	(Reserved)	(Reserved)
	2	T1	Detected digital output fault
	3	T2	
	4	T3	
	5	T4	
	6	T5	
	7	T6	
	8	T7	
	9	T8	
	10	A1	
	11	A2	
	12	A3	
	13	A4	
	14	A5	
	15	T9	

Register	Bit	Code	Description
SelfDiag2	0 (LSB)	T10	Detected digital output fault
	1	T11	
	2	T12	
	3	T13	
	4	T14	
	5	T15	
	6	T16	
	7	T17	
	8	T18	
	9	T19	
	10	T20	
	11	T21	
	12	T22	
	13	T23	
	14	T24	
SelfDiag4	0 (LSB)	+12V	Detected internal voltage fault
	1	ComBuff	BUS: detected buffer error
	2	Order Code	Detected order code error
	3	Slot card	Detected option card error
	4	FPGA conf.	Detected FPGA configuration error
	5	I/O unit	Detected ARC I/O unit error
	6	Arc sensor	Detected faulty arc sensor
	7	QD-card error	Detected QD-card error
	8	BI	Detected ARC BI error
	9	LowAux	Low auxiliary supply voltage

The code is displayed in self-diagnostic events and on the diagnostic menu on the local panel and Easergy Pro.

**NOTE:** All signals are not necessarily available in every Easergy P3 product.

---

# 13 Order code

When ordering, state:

- Order code of the relay
- Quantity
- Accessories (see the order codes in section Accessories)



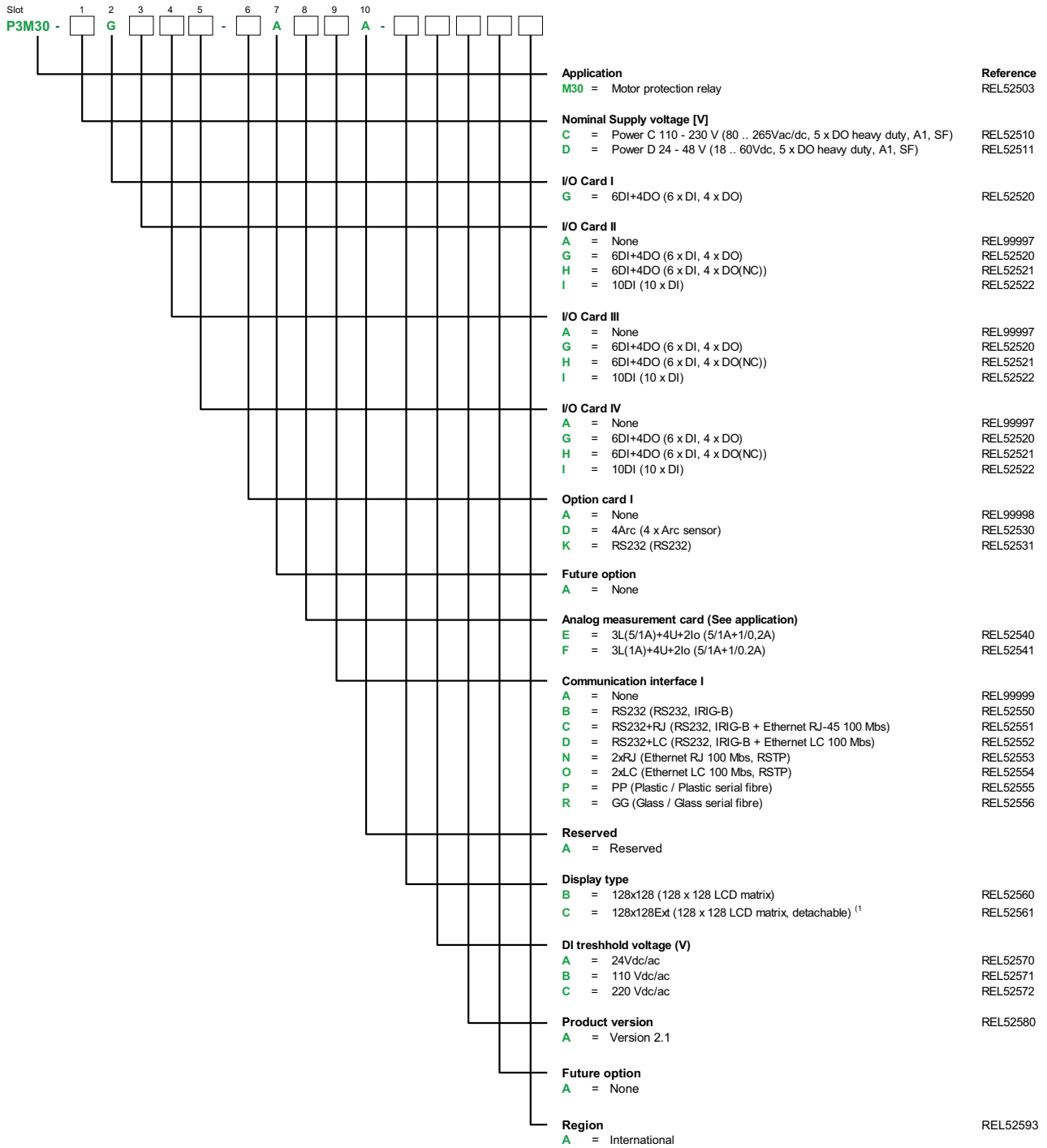

1) By default, the cable length is 2 m (6.56 ft). You can order cables of other length separately: VX001-1 (1 m/3.28 ft), Vx001-3 (3 m/9.84 ft) or VX001-5 (5 m/16.40 ft).

**NOTE:** All PCBA cards are conformally coated.

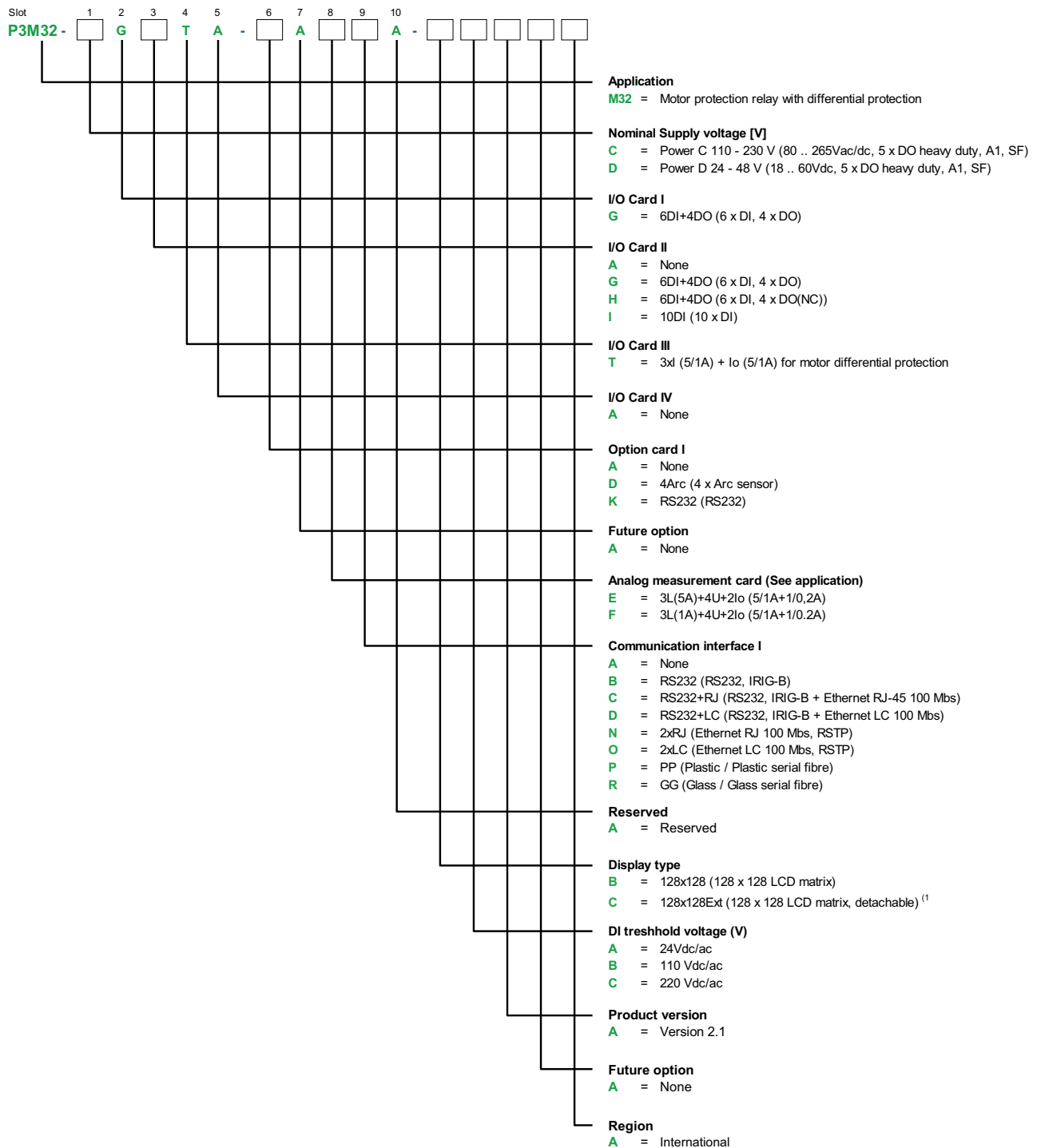

1) By default, the cable length is 2 m (6.56 ft). You can order cables of other length separately: VX001-1 (1 m/3.28 ft), Vx001-3 (3 m/9.84 ft) or VX001-5 (5 m/16.40 ft).

**NOTE:** All PCBA cards are conformally coated.

## Accessories

**Table 13.1: Easergy P3M30 and P3M32 accessories**

Order code	Product Reference	Description
REL52801	VA1DA-20	Arc sensor, 20 m (66 ft)
REL52803	VA1DA-20S	Arc sensor, 20 m (66 ft), shielded
REL52804	VA1DA-6	Arc sensor, 6 m (20 ft) connect cable
REL52806	VA1DA-6S	Arc sensor, 6 m (20 ft), shielded
REL52807	VA1EH-20	Arc sensor, 20 m (66 ft) pipe sensor
REL52809	VA1EH-6	Arc sensor, 6 m (20 ft) pipe sensor
REL52812	VIO12ABSE	RTD module, 12pcs RTD inputs, RS485
REL52813	VIO12ACSE	RTD module, 12pcs RTD inputs, mA in/out
REL52814	VIO12ADSE	RTD module, 12pcs RTD inputs, mA in/out
REL52815	VPA3CGSE	Profibus interface module
REL52816	VSE001-GGSE	Fiber optic module (Glass - Glass)
REL52819	VSE001-PPSE	Fiber optic module (Plastic - Plastic)
REL52820	VSE002	RS485 module
REL52821	VSE009	DeviceNet module
REL52822	VX052-3	USB programming cable (eSetup Easergy Pro)
REL52823	VX067	P3x split cable for COM1-2&COM3-4 ports
REL52824	VX072	P3x Profibus cable
REL52832	VYX695	Raising frame, P3x, 45 mm (1.8 in)

# 14 Firmware revision

**Table 14.1: Firmware revisions**

FW revision	Changes
<b>Version:</b> 30.108 <b>Release date:</b> December 2018	<ul style="list-style-type: none"> <li>• Intermittent earth fault (ANSI 67NI) changed:             <ul style="list-style-type: none"> <li>- New start setting "Sensitive/Normal" and <math>U_0</math> check for trip added</li> </ul> </li> <li>• CB condition monitoring upgraded with opening counts and opening, closing and charging times</li> <li>• Fault locator enhanced to allow multiple line segments.</li> <li>• LED matrix in P3x3x enhanced:             <ul style="list-style-type: none"> <li>- LEDs can now be configured more flexibly.</li> <li>- It is now possible to select for each individual LED whether it should be blinking, latched, or non-volatile (keep its state over reboot).</li> <li>- Each LED also has a configurable description, one for green colour and another for red.</li> </ul> </li> <li>• COMTRADE files can be read over Modbus.</li> <li>• Product and vendor data changed to Schneider Electric in EDS file. This change affects CIP protocols: DeviceNet and EtherNet/IP.</li> <li>• Pole slip protection (ANSI 78) added for P30G and P3G32.</li> <li>• New CBFP functions added: "CBFP1" and "CBFP2".</li> <li>• Restricted earth fault protection (ANSI 64REF) for P3T32 and P3G32.</li> <li>• Faulty phase detection added for ANSI 67N (<math>I_0Dir</math>) stage.</li> <li>• Ethernet's redundancy protocols are now in separate menus.</li> </ul>
<b>Version:</b> 30.106 <b>Release date:</b> 16.5.2018	<ul style="list-style-type: none"> <li>• The setting "Inv. time coefficient k" in stages <math>I&gt;</math>, <math>I\phi&gt;</math>, <math>I\phi&gt;&gt;</math>, <math>I_0&gt;</math>, <math>I_0\phi&gt;</math>, <math>I_0\phi&gt;&gt;</math>, <math>I_0\phi&gt;&gt;&gt;</math> has three decimals instead of two and the minimum value for the earth fault overcurrent was changed from 0.05 to 0.025.</li> <li>• Communication protocol updates</li> </ul>
<b>Version:</b> 30.104 <b>Release date:</b> 2.10.2017	First release





## Customer Care Centre

<http://www.schneider-electric.com/CCC>

**Schneider Electric**

35 rue Joseph Monier  
92500 Rueil-Malmaison  
FRANCE

Phone: +33 (0) 1 41 29 70 00

Fax: +33 (0) 1 41 29 71 00

[www.schneider-electric.com](http://www.schneider-electric.com)

Publication version: P3M/en M/B004

Publishing: Schneider Electric

12/2018