

MiCOM P821

Breaker Failure Protection

P821/EN T/J31

Software Version 10.E
Hardware Suffix Issue 2

Technical Guide

Note

The technical manual for this device gives instructions for its installation, commissioning, and operation. However, the manual cannot cover all conceivable circumstances or include detailed information on all topics. In the event of questions or specific problems, do not take any action without proper authorization. Contact the appropriate Schneider Electric technical sales office and request the necessary information.

Any agreements, commitments, and legal relationships and any obligations on the part of Schneider Electric including settlements of warranties, result solely from the applicable purchase contract, which is not affected by the contents of the technical manual.

This device **MUST NOT** be modified. If any modification is made without the express permission of Schneider Electric, it will invalidate the warranty, and may render the product unsafe.

The Schneider Electric logo and any alternative version thereof are trademarks and service marks of Schneider Electric.

All trade names or trademarks mentioned herein whether registered or not, are the property of their owners.

This manual is provided for informational use only and is subject to change without notice.

© 2012, Schneider Electric. All rights reserved.

CONTENTS

Chapter Number	Chapter	Chapter ID
	Safety Information	Pxxx/EN SI/G12
1	Introduction	P821/EN IT/I31
2	Installation	P821/EN IN/I31
3	User Guide	P821/EN FT/I31
4	Menu Content Tables	P821/EN HI/I31
5	Application Guide	P821/EN AP/J31
6	Connection Diagrams	P821/EN CO/I31
7	Technical Data	P821/EN TD/I31
8	Communications	P821/EN CT/I31
9	Commissioning Guide	P821/EN CM/I31
10	Hardware/Software Version History	P821/EN VC/J31
11	Symbols and Glossary	Pxxx/EN SG/A05

Notes:

SAFETY INFORMATION

CHAPTER SI

CONTENTS

1	INTRODUCTION	5
2	HEALTH AND SAFETY	6
3	SYMBOLS AND LABELS ON THE EQUIPMENT	7
3.1	Symbols	7
3.2	Labels	7
4	INSTALLING, COMMISSIONING AND SERVICING	8
5	DE-COMMISSIONING AND DISPOSAL	11
6	TECHNICAL SPECIFICATIONS FOR SAFETY	12
6.1	Protective Fuse Rating	12
6.2	Protective Class	12
6.3	Installation Category	12
6.4	Environment	12

Notes:

1 INTRODUCTION

This guide and the relevant equipment documentation provide full information on safe handling, commissioning and testing of this equipment. This Safety Information section also includes reference to typical equipment label markings.

Documentation for equipment ordered from Schneider Electric is dispatched separately from manufactured goods and may not be received at the same time. Therefore this guide is provided to ensure that printed information which may be present on the equipment is fully understood by the recipient.

The technical data in this Safety Information section is typical only, see the technical data section of the relevant product publication(s) for data specific to a particular equipment.

**WARNING**

Before carrying out any work on the equipment the user should be familiar with the contents of this Safety Information section and the ratings on the equipment's rating label.

Reference should be made to the external connection diagram before the equipment is installed, commissioned or serviced.

Language-specific, self-adhesive User Interface labels are provided in a bag for some equipment.

2 HEALTH AND SAFETY

The information in the Safety Information section of the equipment documentation is intended to ensure that equipment is properly installed and handled in order to maintain it in a safe condition.

It is assumed that everyone who will be associated with the equipment will be familiar with the contents of that Safety Information section, or this Safety Guide.

When electrical equipment is in operation, dangerous voltages will be present in certain parts of the equipment. Failure to observe warning notices, incorrect use, or improper use may endanger personnel and equipment and also cause personal injury or physical damage.

Before working in the terminal strip area, the equipment must be isolated.

Proper and safe operation of the equipment depends on appropriate shipping and handling, proper storage, installation and commissioning, and on careful operation, maintenance and servicing. For this reason only qualified personnel may work on or operate the equipment.

Qualified personnel are individuals who:

- Are familiar with the installation, commissioning, and operation of the equipment and of the system to which it is being connected;
- Are able to safely perform switching operations in accordance with accepted safety engineering practices and are authorized to energize and de-energize equipment and to isolate, ground, and label it;
- Are trained in the care and use of safety apparatus in accordance with safety engineering practices;
- Are trained in emergency procedures (first aid).

The equipment documentation gives instructions for its installation, commissioning, and operation. However, the manuals cannot cover all conceivable circumstances or include detailed information on all topics. In the event of questions or specific problems, do not take any action without proper authorization. Contact the appropriate Schneider Electric technical sales office and request the necessary information.

3 SYMBOLS AND LABELS ON THE EQUIPMENT

For safety reasons the following symbols and external labels, which may be used on the equipment or referred to in the equipment documentation, should be understood before the equipment is installed or commissioned.

3.1 Symbols



Caution: refer to equipment documentation



Caution: risk of electric shock



Protective Conductor (*Earth) terminal



Functional/Protective Conductor (*Earth) terminal

Note: This symbol may also be used for a Protective Conductor (Earth) Terminal if that terminal is part of a terminal block or sub-assembly e.g. power supply.

***CAUTION: The term “Earth” used throughout this technical manual is the direct equivalent of the North American term “Ground”.**

3.2 Labels

See Safety Guide (SFTY/4L M) for typical equipment labeling information.

**Manual Handling**

Plan carefully, identify any possible hazards and determine whether the load needs to be moved at all. Look at other ways of moving the load to avoid manual handling. Use the correct lifting techniques and Personal Protective Equipment to reduce the risk of injury.

Many injuries are caused by:

- Lifting heavy objects
- Lifting things incorrectly
- Pushing or pulling heavy objects
- Using the same muscles repetitively.

Follow the Health and Safety at Work, etc Act 1974, and the Management of Health and Safety at Work Regulations 1999.

**Equipment Connections**

Personnel undertaking installation, commissioning or servicing work for this equipment should be aware of the correct working procedures to ensure safety.

The equipment documentation should be consulted before installing, commissioning, or servicing the equipment.

Terminals exposed during installation, commissioning and maintenance may present a hazardous voltage unless the equipment is electrically isolated.

The clamping screws of all terminal block connectors, for field wiring, using M4 screws shall be tightened to a nominal torque of 1.3 Nm.

Equipment intended for rack or panel mounting is for use on a flat surface of a Type 1 enclosure, as defined by Underwriters Laboratories (UL).

Any disassembly of the equipment may expose parts at hazardous voltage, also electronic parts may be damaged if suitable ElectroStatic voltage Discharge (ESD) precautions are not taken.

If there is unlocked access to the rear of the equipment, care should be taken by all personnel to avoid electric shock or energy hazards.

Voltage and current connections shall be made using insulated crimp terminations to ensure that terminal block insulation requirements are maintained for safety.

Watchdog (self-monitoring) contacts are provided in numerical relays to indicate the health of the device. Schneider Electric strongly recommends that these contacts are hardwired into the substation's automation system, for alarm purposes.

To ensure that wires are correctly terminated the correct crimp terminal and tool for the wire size should be used.

The equipment must be connected in accordance with the appropriate connection diagram.

**Protection Class I Equipment**

- Before energizing the equipment it must be earthed using the protective conductor terminal, if provided, or the appropriate termination of the supply plug in the case of plug connected equipment.
- The protective conductor (earth) connection must not be removed since the protection against electric shock provided by the equipment would be lost.
- When the protective (earth) conductor terminal (PCT) is also used to terminate cable screens, etc., it is essential that the integrity of the protective (earth) conductor is checked after the addition or removal of such functional earth connections. For M4 stud PCTs the integrity of the protective (earth) connections should be ensured by use of a locknut or similar.

The recommended minimum protective conductor (earth) wire size is 2.5 mm² (3.3 mm² for North America) unless otherwise stated in the technical data section of the equipment documentation, or otherwise required by local or country wiring regulations.

The protective conductor (earth) connection must be low-inductance and as short as possible.

All connections to the equipment must have a defined potential. Connections that are pre-wired, but not used, should preferably be grounded when binary inputs and output relays are isolated. When binary inputs and output relays are connected to common potential, the pre-wired but unused connections should be connected to the common potential of the grouped connections.



Pre-Energization Checklist

Before energizing the equipment, the following should be checked:

- Voltage rating/polarity (rating label/equipment documentation);
- CT circuit rating (rating label) and integrity of connections;
- Protective fuse rating;
- Integrity of the protective conductor (earth) connection (where applicable);
- Voltage and current rating of external wiring, applicable to the application.



Accidental Touching of Exposed Terminals

If working in an area of restricted space, such as a cubicle, where there is a risk of electric shock due to accidental touching of terminals which do not comply with IP20 rating, then a suitable protective barrier should be provided.



Equipment Use

If the equipment is used in a manner not specified by the manufacturer, the protection provided by the equipment may be impaired.



Removal of the Equipment Front Panel/Cover

Removal of the equipment front panel/cover may expose hazardous live parts, which must not be touched until the electrical power is removed.



UL and CSA/CUL Listed or Recognized Equipment

To maintain UL and CSA/CUL Listing/Recognized status for North America the equipment should be installed using UL or CSA Listed or Recognized parts for the following items: connection cables, protective fuses/fuseholders or circuit breakers, insulation crimp terminals and replacement internal battery, as specified in the equipment documentation.

For external protective fuses a UL or CSA Listed fuse shall be used. The Listed type shall be a Class J time delay fuse, with a maximum current rating of 15 A and a minimum d.c. rating of 250 Vd.c., for example type AJT15.

Where UL or CSA Listing of the equipment is not required, a high rupture capacity (HRC) fuse type with a maximum current rating of 16 Amps and a minimum d.c. rating of 250 Vd.c. may be used, for example Red Spot type NIT or TIA.



Equipment Operating Conditions

The equipment should be operated within the specified electrical and environmental limits.



Current Transformer Circuits

Do not open the secondary circuit of a live CT since the high voltage produced may be lethal to personnel and could damage insulation. Generally, for safety, the secondary of the line CT must be shorted before opening any connections to it.

For most equipment with ring-terminal connections, the threaded terminal block for current transformer termination has automatic CT shorting on removal of the module. Therefore external shorting of the CTs may not be required, the equipment documentation should be checked to see if this applies.

For equipment with pin-terminal connections, the threaded terminal block for current transformer termination does NOT have automatic CT shorting on removal of the module.



External Resistors, including Voltage Dependent Resistors (VDRs)

Where external resistors, including Voltage Dependent Resistors (VDRs), are fitted to the equipment, these may present a risk of electric shock or burns, if touched.



Battery Replacement

Where internal batteries are fitted they should be replaced with the recommended type and be installed with the correct polarity to avoid possible damage to the equipment, buildings and persons.

**Insulation and Dielectric Strength Testing**

Insulation testing may leave capacitors charged up to a hazardous voltage. At the end of each part of the test, the voltage should be gradually reduced to zero, to discharge capacitors, before the test leads are disconnected.

**Insertion of Modules and PCB Cards**

Modules and PCB cards must not be inserted into or withdrawn from the equipment whilst it is energized, since this may result in damage.

**Insertion and Withdrawal of Extender Cards**

Extender cards are available for some equipment. If an extender card is used, this should not be inserted or withdrawn from the equipment whilst it is energized. This is to avoid possible shock or damage hazards. Hazardous live voltages may be accessible on the extender card.

**External Test Blocks and Test Plugs**

Great care should be taken when using external test blocks and test plugs such as the MMLG, MMLB and MiCOM P990 types, hazardous voltages may be accessible when using these. *CT shorting links must be in place before the insertion or removal of MMLB test plugs, to avoid potentially lethal voltages.

**Note: When a MiCOM P992 Test Plug is inserted into the MiCOM P991 Test Block, the secondaries of the line CTs are automatically shorted, making them safe.*

**Fiber Optic Communication**

Where fiber optic communication devices are fitted, these should not be viewed directly. Optical power meters should be used to determine the operation or signal level of the device.

**Cleaning**

The equipment may be cleaned using a lint free cloth dampened with clean water, when no connections are energized. Contact fingers of test plugs are normally protected by petroleum jelly, which should not be removed.

5

DE-COMMISSIONING AND DISPOSAL

**De-commissioning**

The supply input (auxiliary) for the equipment may include capacitors across the supply or to earth. To avoid electric shock or energy hazards, after completely isolating the supplies to the equipment (both poles of any dc supply), the capacitors should be safely discharged via the external terminals prior to de-commissioning.

**Disposal**

It is recommended that incineration and disposal to water courses is avoided. The equipment should be disposed of in a safe manner. Any equipment containing batteries should have them removed before disposal, taking precautions to avoid short circuits. Particular regulations within the country of operation, may apply to the disposal of the equipment.

6 TECHNICAL SPECIFICATIONS FOR SAFETY

Unless otherwise stated in the equipment technical manual, the following data is applicable.

6.1 Protective Fuse Rating

The recommended maximum rating of the external protective fuse for equipments is 16A, High Rupture Capacity (HRC) Red Spot type NIT, or TIA, or equivalent. Unless otherwise stated in equipment technical manual, the following data is applicable. The protective fuse should be located as close to the unit as possible.



DANGER CTs must NOT be fused since open circuiting them may produce lethal hazardous voltages.

6.2 Protective Class

IEC 60255-27: 2005	Class I (unless otherwise specified in the equipment documentation).
EN 60255-27: 2005	This equipment requires a protective conductor (earth) connection to ensure user safety.

6.3 Installation Category

IEC 60255-27: 2005	Installation Category III (Overvoltage Category III)
EN 60255-27: 2005	Distribution level, fixed installation.
	Equipment in this category is qualification tested at 5 kV peak, 1.2/50 μ s, 500 Ω , 0.5 J, between all supply circuits and earth and also between independent circuits.

6.4 Environment

The equipment is intended for indoor installation and use only. If it is required for use in an outdoor environment then it must be mounted in a specific cabinet of housing which will enable it to meet the requirements of IEC 60529 with the classification of degree of protection IP54 (dust and splashing water protected).

Pollution Degree	Pollution Degree 2 Compliance is demonstrated by reference to safety standards.
Altitude	Operation up to 2000m

INTRODUCTION

CHAPTER 1

Date (month/year)	02/2016
Software Version	10.E
Hardware Suffix	Phase 2
Serial Number	Hardware installed

CONTENTS

Page (IT) 1-

1	How to Use this Manual	5
2	Introduction to the Relay	6
3	Main Functions	7
4	Equivalence Tables	8

TABLES

Page (IT) 1-

Table 1 - MiCOM P821 main functions	7
Table 2 - MiCOM P821 and functionally-equivalent models	8

Notes:

1 HOW TO USE THIS MANUAL

The MiCOM P821 relay has been designed to control, protect and monitor industrial installations, public distribution networks and substations, and to be used as back-up protection for EHV and HV transmission networks. This manual provides a description of the relays functions and settings. It enables the user to become familiar with the application, installation, setting and commissioning of these relays. This manual has the following format:

Chapter No	Description	Document ID Number
	Safety Information	Pxxx/EN SI
	This chapter provides safety-related details which apply to every-one who may come into contact with this or any other relay.	
1	Introduction	P821/EN IT
	This chapter provides details of the contents of this manual and gives a general introduction to the relay.	
2	Installation	P821/EN IN
	This chapter provides handling and installation information; as well as the precautions to be taken when handling electronic equipment. It also provides information about case dimensions for the relay.	
3	User Guide	P821/EN FT
	This chapter provides a detailed description of the features of the relay.	
4	Menu Content Diagrams	P821/EN HI
	This chapter provides a detailed map of the various menus available on the relay.	
5	Application Guide	P821/EN AP
	This chapter provides a description of common power system applications of the relay, calculations of suitable settings, some typical worked examples, and how to apply the settings to the relay.	
6	Connection Diagrams	P821/EN CO
	This chapter provides a mechanical and electrical description of the relay - including details of any external wiring connections.	
7	Technical Data	P821/EN TD
	This chapter provides comprehensive details on nominal values, setting ranges, specifications and curve characteristics.	
8	Communications	P821/EN CT
	This chapter provides an overview regarding the communication interfaces of the relay. Detailed protocol mappings, semantics, profiles and interoperability tables are not provided within this manual. Separate documents are available per protocol, available for download from our website.	
9	Commissioning Guide	P821/EN CM
	This chapter provides instructions on how to commission the relay, comprising checks on the calibration and functionality of the relay are included.	
10	Hardware/Software Version History	P821/EN VC
	This chapter provides a history of all hardware and software releases for the product.	
11	Symbols and Glossary	Pxxx/EN SG
	This chapter provides a list of commonly used abbreviations, symbols and industry-standard terminology.	

2 INTRODUCTION TO THE RELAY

The range of MiCOM protection relays follows on from the success of the MIDOS, K and MODN ranges by incorporating the last changes in digital technology. The relay provides more protection for the most demanding applications.

Each relay has a large number of functions for controlling and collecting data. This can form part of a fully integrated system covering protection, control, instrumentation, data acquisition and the recording of faults, events and disturbances. The relays are equipped on the front panel with a Liquid Crystal Display (LCD) with 2 x 16 back-lit alphanumerical characters, a tactile seven-button keypad (to gain access to all the parameters, alarms and measurements) and eight LEDs simply displaying the state of the relay. In addition, the use of the RS485 communication port makes it possible to read, re-initialise and change the settings of the relays, if required, from a local or remote PC computer equipped with the software MiCOM S1.

Its flexibility of use, reduced maintenance requirements and ease of integration allow the relay to provide an evolving solution for the problems of the protection of electric networks.

The relay provides comprehensive breaker fail phase and earth fault protection for utilities networks, industrial plants and networks in addition to other applications where breaker fail protection is required. The earth fault protection is sufficiently sensitive for electric networks in which the earth fault current is low.

3 MAIN FUNCTIONS

Table 1 shows the functions available for the MiCOM P821 relay.

Functions	ANSI Code	MiCOM P821
CB FAIL	50BF (Ph), I<	X
CB FAIL Earth	50BF (N), IN<	X
CB FAIL Negative Sequence Current	50BF, I2<	X
Stage 1 Timer	tBF1	X
Stage 2 Timer	tBF2	X
Dead Zone (End Zone)	DBI	X
Pole discrepancy	Poles Not Together	X
Circuit Breaker monitoring, control and Statistics		X
Auxiliary timers	tAUX	2
Latching output contacts	86, Lockout	X
Setting groups		2
Measurements (True RMS)	Metering	4
Event records	SOE	250
Fault records		25
Disturbance records	Oscillography	15 sec
RS 232 front communication	Comms	X
RS 485 rear communication	Comms	X

Table 1 - MiCOM P821 main functions

4 EQUIVALENCE TABLES

Table 2 shows the MiCOM P821 relay together with other existing relays:

MiCOM range	MIDOS range	TROPIC2 range	K range
P821	MCTI 14, 34, 44 MCTI 15, 35 with MVTT 14, 15		

Table 2 - MiCOM P821 and functionally-equivalent models

INSTALLATION

CHAPTER 2

Date (month/year)	02/2016
Software Version	10.E
Hardware Suffix	Phase 2
Serial Number	Hardware installed

CONTENTS

Page (IN) 2-

1	Receipt and Handling of Relays	5
1.1	Receipt of Relays	5
1.2	ElectroStatic Discharge (ESD)	5
1.3	Handling Electronic Equipment	5
1.4	Mechanical Handling	6
1.4.1	Relay Mounting	6
1.4.2	Unpacking	6
1.4.3	Storage	6
2	Dimensions	7
2.1	Connection of Power Terminals, and Signals Terminals	7
2.2	RS485 Communication port	8
2.3	Earthing	8
3	Case Dimensions	9

FIGURES

Page (IN) 2-

Figure 1 - Connection of Push-on Connectors	7
Figure 2 - Connection of Ring Tongue Terminals	7
Figure 3 - Relay case dimensions	9

Notes:

1 RECEIPT AND HANDLING OF RELAYS

1.1 Receipt of Relays

Protective relays, although generally of robust construction, require careful treatment before installation on site. On receipt, relays should be examined immediately to ensure no damage has been sustained in transit. If damage has been sustained during transit a claim should be made to the transport contractor and Schneider Electric should be promptly notified.

Relays that are supplied unmounted and not intended for immediate installation should be returned to their protective polythene bags.

1.2 ElectroStatic Discharge (ESD)

The relays use components that are sensitive to electrostatic discharges.

The electronic circuits are well protected by the metal case. Do not remove the internal module from the case unnecessarily. When handling the module outside its case, care should be taken to avoid contact with components and electrical connections. If removed from the case for storage, the module should be placed in an electrically conducting anti-static bag.

The internal module has no setting adjustments and should not be disassembled unnecessarily. Although the printed circuit boards are plugged together, the connectors are a manufacturing aid. They are not intended for frequent dismantling and considerable effort may be required to separate them. Touching the printed circuit board should be avoided, since Complementary Metal Oxide Semiconductors (CMOS) are used, which can be damaged by static electricity discharged from the body.

1.3 Handling Electronic Equipment

A person's normal movements can easily generate electrostatic potentials of several thousand volts. Discharge of these voltages into semiconductor devices when handling electronic circuits can cause serious damage, which often may not be immediately apparent but reduces the reliability of the circuit.

The electronic circuits are protected from electrostatic discharge when housed in the case. Do not expose them to risk of damage by withdrawing modules unnecessarily.

Each module incorporates the highest practicable protection for its semiconductor devices. However, if it becomes necessary to withdraw a module, the following precautions should be taken to preserve the high reliability and long life for which the equipment has been designed and manufactured.

1. Before removing a module, touch the case to ensure that you are at the same electrostatic potential as the equipment.
2. Handle the modules by their frame and printed circuit boards by the edges only. Do not touch the electronic components, printed circuit tracks or connectors.
3. Do not pass the module to another person without first ensuring you are both at the same electrostatic potential. Shaking hands achieves this.
4. Place the module on an anti-static surface, or on a conducting surface which is at the same potential as yourself. Touching the surface achieves this.
5. Store or transport the module in a conductive bag.

If you are making measurements on the internal electronic circuitry of equipment in service, wear a conductive wrist strap earthed (grounded) to the case. Wrist straps should have a resistance to ground between 500k Ω – 10M Ω .

If a wrist strap is not available keep regular contact with the case to prevent a build-up of static potential. Instrumentation which may be used for making measurements should be earthed to the case whenever possible.

Detailed investigations on electronic circuitry or modification work should be carried out in a special handling. For more information on safe working procedures for all electronic equipment, see BS5783 and IEC 147-OF.

1.4 Mechanical Handling

1.4.1 Relay Mounting

Relays are dispatched either individually or as part of a panel or rack assembly.

If a MMLG or a P99x test block is to be included it should be positioned at the right-hand side of the assembly (viewed from the front). Modules should remain protected by their metal case during assembly into a panel or rack.

For individually mounted relays an outline diagram is supplied in section 6 of this chapter showing the panel cut-outs and hole centres.

1.4.2 Unpacking

Care must be taken when unpacking and installing the relays so that none of the parts is damaged or the settings altered. Relays must only be handled by skilled personnel. The installation should be clean, dry and reasonably free from dust and excessive vibration. The site should be well lit to facilitate inspection. Relays that have been removed from their cases should not be left in situations where they are exposed to dust or damp. This particularly applies to installations which are being carried out at the same time as construction work.

1.4.3 Storage

If relays are not to be installed immediately on receipt, they should be stored in a place free from dust and moisture in their original cartons. Where de-humidifier bags have been included in the packing they should be retained. The action of the de-humidifier crystals will be impaired if the bag has been exposed to ambient conditions and may be restored by gently heating the bag for about an hour, before replacing it in the carton.

Dust which collects on a carton may, on subsequent unpacking, find its way into the relay. In damp conditions the carton and packing may become impregnated with moisture and the de-humidifier will lose its efficiency.

Storage temperature : –25°C to +70°C.

2 DIMENSIONS

2.1 Connection of Power Terminals, and Signals Terminals

The individual equipment are delivered with sufficient M4 screws to connect the relay using annular terminals, with a maximum recommended of two annular terminals per contact.

If necessary, Schneider Electric can provide annular terminals to crimp. Five references exist according to the section of the wire (see Figure 1 and Figure 2). Each reference corresponds to a sachet of 100 terminals.

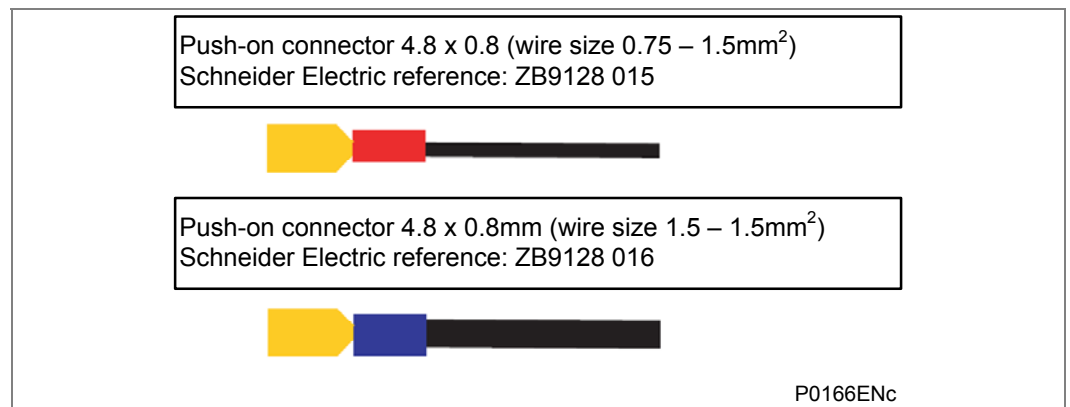

Figure 1 - Connection of Push-on Connectors

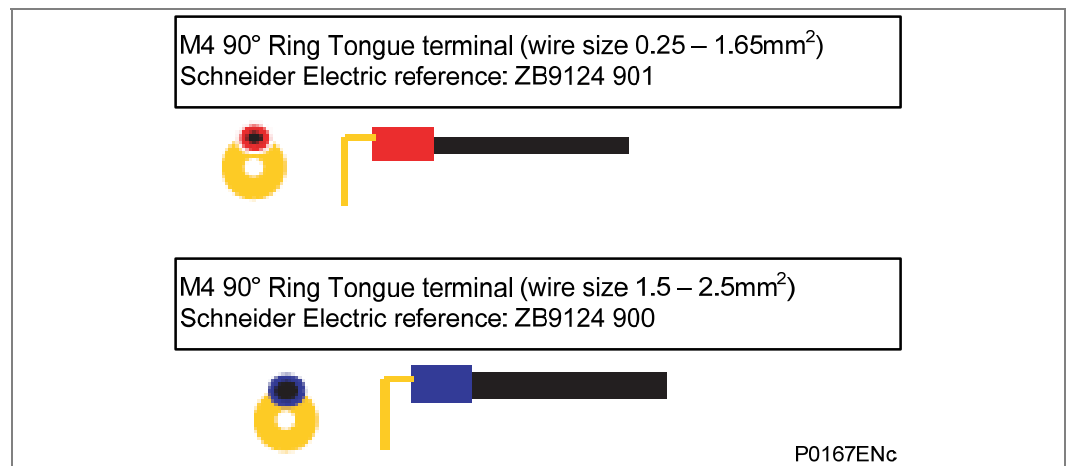

Figure 2 - Connection of Ring Tongue Terminals

To ensure the terminals are correctly insulated and to respect the security and safety instructions, an isolating sleeve can be used.

We recommend the following cable cross-sections:

- Auxiliary sources Vaux: 1.5 mm²
- Communication Port see the Connection Diagrams chapter
- Other circuits 1.0 mm²

Because of the limitations of the annular terminals, the maximum wire cross-section which can be used for the connector blocks (for current inputs and signals) is 6 mm² by using non -insulated annular terminals. When only pre-insulated terminals can be used, the maximum wire cross-section is reduced to 2.63 mm² for each annular terminal. If a more significant wire cross-section is necessary, two wires can be put in parallel, each one finished by a separate annular terminal.

All the terminal blocks used for connections, except of the RS485 port, must be able to withstand a nominal voltage of minimum 300 V peak value.

We recommend using a type NIT or TIA fuse rated at 16 A to protect the auxiliary source connection. For security reasons, never install fuses in current transformer circuits. The other circuits must be protected by fuses.

2.2 RS485 Communication port

RS485 connections are made using annular terminals. A two core screened cable is recommended with a maximum total length of 1000 m or a200 nF total cable capacitance.

Typical specification:

- Each core : 16/0.2 mm copper conductor, PVC insulated.
- Nominal conductor area : 0.5 mm² per core
- Screen : Overall braid, PVC sheathed
- Linear capacitance between conductor and earth : 100pF/m

2.3 Earthing

Each item of equipment must be connected to a local earth terminal by the intermediary of M4 earth terminals. We recommend a wire of minimal section of 2.5 mm², with annular terminals on the side of the equipment. Because of the limitations of the annular terminals, the possible wire section is 6 mm². If a larger section is necessary, use cables connected in parallel, each one ending with an annular terminal separated on the side of the equipment. Also a metal bar can be used.

<i>Note</i>	<i>To prevent any electrolytic risk between the copper conductor or brass conductor and the back plate of the equipment, isolate them from each other. For example, this can be done by inserting a plated nickel or insulated ring washer between the conductor and the case or by using tin terminals.</i>
-------------	--------------------------------------------------------------------------------------------------------------------------------------------------------------------------------------------------------------------------------------------------------------------------------------------------------------

3 CASE DIMENSIONS

The MiCOM P821 relay is available in a 4U metal case for panel or flush mounting.

Weight :	2.1 Kg		
External size :	Height	case	152 mm
		front panel	177 mm
	Width	case	97 mm
		front panel	103 mm
	Depth	case	226 mm
		front panel + case	252 mm

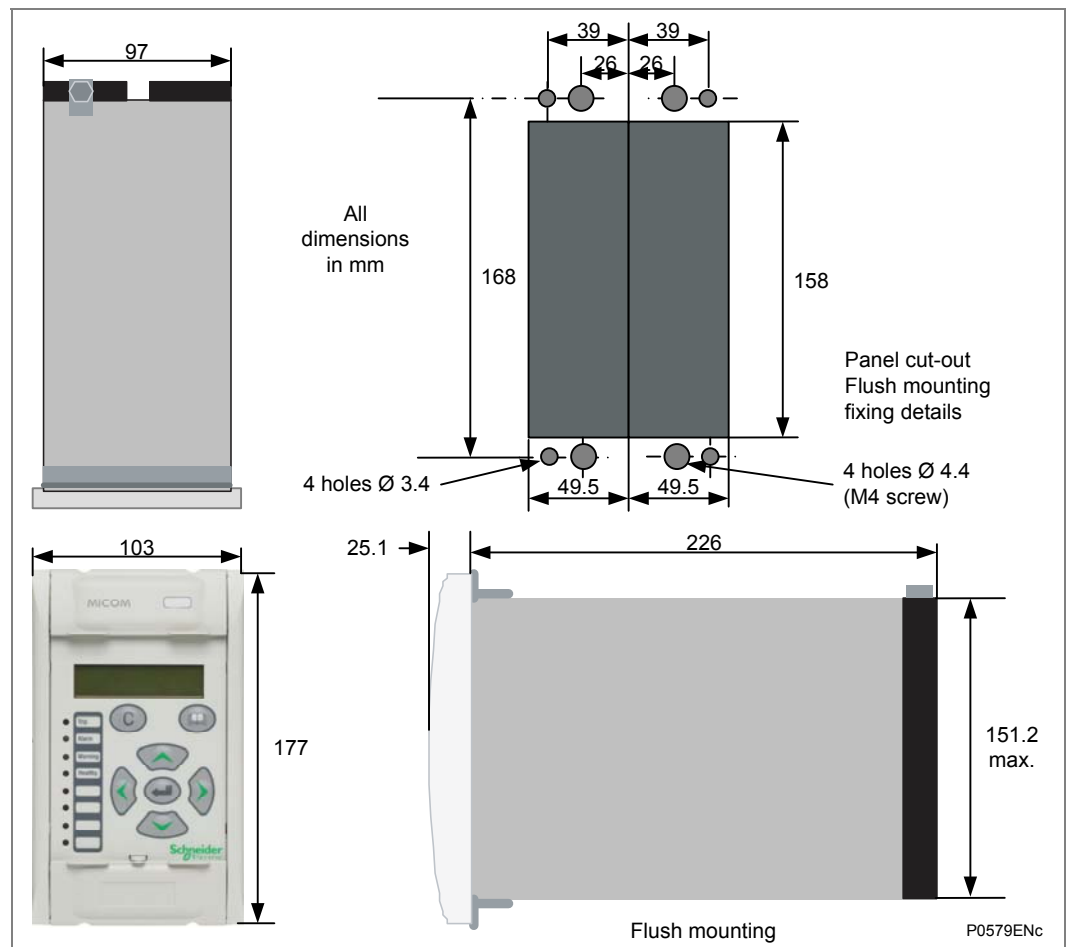

Figure 3 - Relay case dimensions

Note For flush mounting, use the screws supplied, with head diameter smaller than the hole of the front face. Otherwise the active part will not be plugged properly (do not add washers). Do not discard these screws.

Notes:

USER GUIDE

CHAPTER 3

Date (month/year)	02/2016
Software Version	10.E
Hardware Suffix	Phase 2
Serial Number	Hardware installed

CONTENTS

Page (FT) 3-

1	Description of the Relay	7
2	User Interface	8
2.1	LCD Display and Keypad Description	8
2.1.1	LCD Display	8
2.1.2	Keypad	9
2.2	LEDs	10
2.3	Under the Top and Bottom Flaps	11
2.3.1	Relay Identification	11
2.3.2	Lower Flap	11
3	Menus	12
3.1	Breaker Fail [50BF]	12
3.1.1	Function	12
3.1.2	Configuration and Logic Inputs	12
3.1.3	Logical Outputs	13
3.2	End Fault Protection (Dead Zone Protection)	13
3.2.1	Function	13
3.2.2	Configuration	13
3.2.3	Outputs	13
3.3	Pole Discrepancy	14
3.3.1	Function	14
3.3.2	Configuration	14
3.3.3	Logic Outputs	14
3.4	Auxiliary Timers	14
3.4.1	Function	14
3.4.2	Configuration	14
3.4.3	Function	14
3.4.4	Outputs	14
3.5	Wiring Security	15
3.5.1	Function	15
3.5.2	Configuration	15
3.5.3	Automation	15
3.5.4	Outputs	15
3.6	CB Monitoring, Control and Statistics	16
3.6.1	Tripping Time Supervision	16
3.6.2	Number of Breaker Operations	16
3.6.3	Sum of Broken Current Squared	16
3.6.4	Statistics	17
3.7	Blocking Logic	17
4	Setting the Protection	18

5	Menu Columns	19
6	General Settings	20
6.1	OP Parameters Menu	20
6.2	Configuration Menu	21
6.2.1	Display Sub-Menu	21
6.2.2	CT Ratio Sub-Menu	21
6.2.3	LEDs 5 To 8 Configuration Sub-Menu	22
6.2.4	Group Select Sub-Menu	24
6.2.5	Alarms Sub-Menu	25
6.2.6	Configuration Inputs Sub-Menu	25
6.2.7	Date Format Sub-Menu	25
6.3	Measurement Menu	26
6.4	Event Counters Menu	26
6.5	Communication Menu	28
6.6	Protection G1 Menu	29
6.6.1	Circuit Breaker Failure Protection Function [50BF] Sub-Menu	29
6.6.2	Dead Zone Protection Function Sub-Menu	30
6.6.3	Poles Discrepancy Function Sub-Menu	31
6.7	Protections (G2) Menu	31
6.8	Automatic Ctrl Menu	31
6.8.1	Trip Command Sub-Menu	31
6.8.2	Latch Trip Order Sub-Menu	33
6.8.3	Output Relays Sub-Menu	34
6.8.4	Latch Output Relays Sub-Menu	36
6.8.5	Inputs Sub-Menu	36
6.8.6	CB Supervision Sub-Menu	38
6.8.7	Wiring Security Sub-Menu	38
6.8.8	Blocking Logic1/2 Sub-Menu	39
6.8.9	Logic Equations Sub-Menu	39
6.9	Records Menu	41
6.9.1	CB Monitoring Sub-Menu	41
6.9.2	Fault Record Sub-Menu	42
6.9.3	Disturbance Record Sub-Menu	42
7	Wiring	43
7.1	Auxiliary Supply	43
7.2	Current Measurement Inputs	43
7.3	Logic Inputs	44
7.4	Output Relays	44
7.5	Communication	44
7.5.1	RS485 Rear Communications Port	44
7.5.2	RS232 Front Communication Port:	44
7.6	Password	45
7.6.1	Password Protection	45
7.6.2	Entering the Password	45

7.6.3	Changing the Password	45
7.7	Alarm Display	46
7.7.1	Electrical System Alarms	46
7.7.2	Relay Hardware or Software Alarms	48

FIGURES

	Page (FT) 3-
Figure 1 - Front panel MICOM P821	8
Figure 2 - P821 keypad	9
Figure 3 - P821 LEDs	10
Figure 4 - Rear connectors	43
Figure 5 - RS232 front port communication cable wiring	44

Notes:

1 DESCRIPTION OF THE RELAY

The MiCOM P821 is a fully numerical relay which provides protection and control functions.

3 phase current inputs are available for 1 A and another 3 phase current inputs for 5 A.

Separate neutral current inputs are also provided for both 1A and 5A.

All the output relays (8 outputs) are fully programmable to respond to any of the available control or protection functions, the Logic inputs (5 inputs) are also settable and can be allocated to various control functions.

The MiCOM P821 can be supplied by either AC or DC voltage auxiliary supply (3 ranges are available). Any short dip (<50ms) is filtered and regulated through the auxiliary supply.

The front panel enables the user to navigate through the menu very easily to get access to data, setting values, measurements and records. Eight LEDs on the front panel allow a clear and simple presentation of the events. The various alarms detected are displayed on the backlit LCD display. No password is needed to read these alarm messages. The setting values can only be modified after entering the password.

For local communication, the relay provides a standard RS232 on the front panel. This is used to connect a PC where the user can communicate with the relay using Schneider Electric setting software MiCOM S1 . This front communication is a MODBUS communication.

The MiCOM P821 provides also a standard RS485 through its rear panel, communication protocol can be chosen when ordering the relay (MODBUS, COURIER, IEC60870-5-103 or DNP3). Using the communication channel, all the stored information (measurements, alarms, and parameters) can be read and the settings can be modified (except IEC60870-5-103 and DNP3). This rear connection allows the P821 to be directly linked to a digital control system (PACiS for example). All the available data are then placed at the disposal of the supervisor and can be processed either locally or remotely.

2 USER INTERFACE

The MiCOM P821 relay front panel allows the user to enter relay settings, display measured values and alarms, and to display the status of the relay.



Figure 1 - Front panel MICOM P821

The front panel of the relay has three separate sections:

- The Liquid Crystal Display (LCD) display and the keypad
- The LEDs
- The two zones under the upper and lower flaps

2.1 LCD Display and Keypad Description

2.1.1 LCD Display

On the front panel, a Liquid Crystal Display (LCD) displays settings, measured values and alarms. Data is accessed through a menu structure.

The LCD has two lines, with sixteen characters each. A back-light is activated when a key is pressed and remains lit for five minutes after the last key press. This allows the user to read the display in most lighting conditions.

2.1.2

Keypad

The keypad has seven keys, divided into two groups

- Two keys just under the screen: clear (C) and read (📖).
- Main keys to navigate through the menus ⬅️, ➡️, ⬆️, ⬇️.

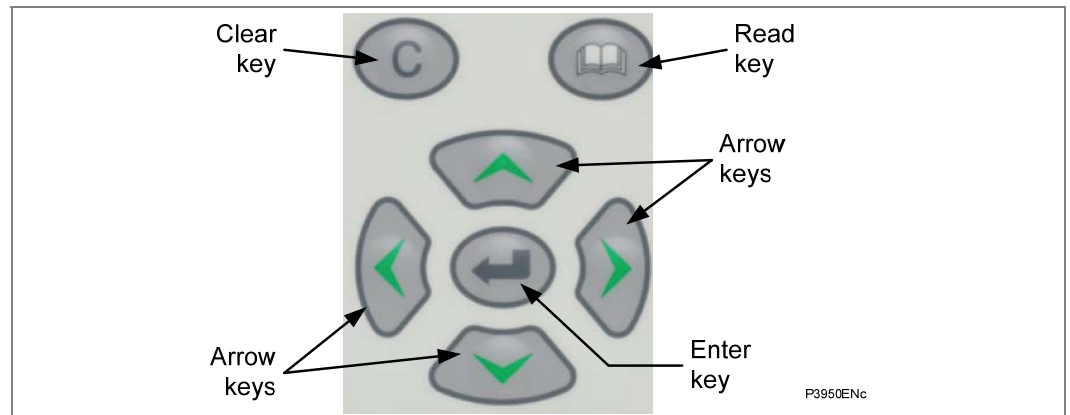

Figure 2 - P821 keypad

2.1.2.1

Alarm Keys

The read (📖) and clear (C) keys are used to read and acknowledge alarms. To display successive alarms, press the read key. The most recent alarm is displayed first. To acknowledge the alarms, either acknowledge each alarm using the clear key or go to the end of the ALARM menu and acknowledge all the alarms at the same time using the clear key.

When navigating through submenus, the clear key is also used to go back to the head line of the corresponding menu.

Note To acknowledge a relay output that is latched, refer to the submenu section.

Warning The alarms can be acknowledged without a password.

2.1.2.2

Programming Keys

The five keys in the middle of the front panel are used to set the relay.

The four arrow keys ⬅️, ➡️, ⬆️, ⬇️ are used to navigate through the menus and submenus and to do the setting of the relay.

The enter key ⏎ is used to validate a choice or value (modification of settings).

2.2 LEDs

The LED labels on the front panel are by default in English, however, **MiCOM** relays are supplied with self-adhesive labels. These are in French or other languages.

The top four LEDs indicate the status of the relay (Trip condition, alarm LED, equipment failure, and auxiliary supply).

The four lower LEDs are user programmable and can be assigned to display, for example, a threshold crossing (available for all models) or to show of the state of the logic inputs and outputs.

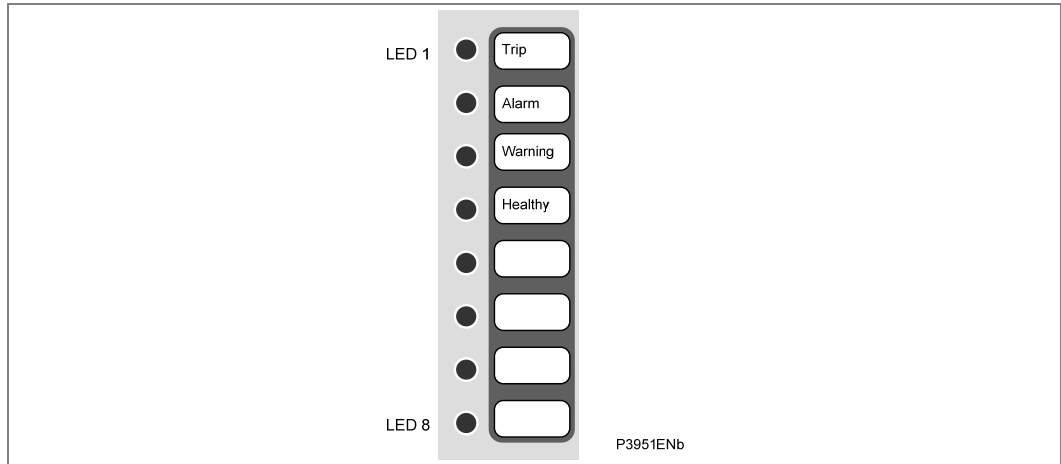

Figure 3 - P821 LEDs

LED No	Colour	Label		
Description				
1	RED	Trip		
LED 1 indicates that the relay has issued a trip order to the circuit breaker. This LED recopies the trip order issued to the trip logic output. Its normal state is OFF. As soon as a triggering order is issued, the LED switches ON. It switches OFF when the associated alarm is acknowledged through the front panel, by a remote command, by a digital input, or by a new fault (CONFIGURATION/Alarms menu).				
2	ORANGE	ALARM		
LED 2 indicates that the relay has detected an alarm. This alarm can either be a threshold crossing (instantaneous), or a trip order (time delayed). As soon as an alarm is detected, the LED flashes. When all the stored alarms are read, the LED switches ON continuously. When all alarms are acknowledged, the LED switches OFF.				
<table border="1"> <tr> <td><i>Note</i></td> <td><i>To configure the instantaneous alarms to be self reset or not, select Yes or No in the CONFIGURATION/Alarms Menu.</i></td> </tr> </table>			<i>Note</i>	<i>To configure the instantaneous alarms to be self reset or not, select Yes or No in the CONFIGURATION/Alarms Menu.</i>
<i>Note</i>	<i>To configure the instantaneous alarms to be self reset or not, select Yes or No in the CONFIGURATION/Alarms Menu.</i>			
The alarm LED can be reset through the front panel, by remote command, by a digital input, or by a new fault (CONFIGURATION/Alarms menu).				
3	ORANGE	Warning		
LED 3 indicates internal alarms of the relay. When the relay detects a non-critical internal alarm (typically a communication failure), the LED flashes continuously. When the relay detects a fault that is considered critical, the LED switches ON continuously. The LED can only be switched off by resolving the cause of the fault.				
4	GREEN	Healthy		
LED 4 indicates that the relay is powered by an auxiliary source at the nominal range.				

LED No	Colour	Label
Description		
5 to 8	RED	Aux.1 to 4
<p>These LEDs are user programmable so by default their labels are blank. These LEDs can be set to display information about instantaneous and time-delayed thresholds as well as the status of the logic inputs and outputs. In the CONFIGURATION/LED menu, select the information required to be associated with each LED. More than one function can be allocated to each LED. The LED switches ON when one or more of the inputs is valid (OR gate), and is cleared when all associated alarms are acknowledged.</p>		

2.3

Under the Top and Bottom Flaps

The active part of the relay can be withdrawn while energised. To do this, open the two flaps, unscrew the four screws, then with a 3 mm screwdriver turn the extractor situated under the upper flap, and pull using the two slots situated behind these flaps.

2.3.1

Relay Identification

Under the upper flap, a label identifies the relay according to its model number (ordering code) and serial number. These two numbers are unique to the particular relay, so in all your requests please refer to these two numbers.

Below the model and serial number, there is information about the voltage level of the auxiliary supply and the nominal earth current value.

2.3.2

Lower Flap

Under the lower flap there is an RS232 port on all MiCOM relays, used to communicate with a PC. The port can be used to upload a new version of the application software into the relay flash memory. Alternatively it can be used to download or retrieve settings using MiCOM S1 Studio software.

3 MENUS

3.1 Breaker Fail [50BF]

3.1.1 Function

When a tripping order is given to a circuit breaker, the circuit breaker failure function makes it possible to check that the circuit breaker opens correctly.

3.1.2 Configuration and Logic Inputs

When the programmed circuit breaker failure protection is invalidated, all the logic outputs are null. The circuit breaker failure function on the phases, ground and negative can be validated independently.

Logic Inputs relevant to Breaker Fail protection initiation are:

- Ext. trip Ph.A: External trip command phase A
- Ext. trip Ph.B: External trip command phase B
- Ext. trip Ph.C: External trip command phase C
- Ext. trip 3 Ph.: External 3 phase trip command
- Ext.Non I Trip: External non-current trip command
- CB Unhealthy: CB unhealthy signal

The phase current detection thresholds are adjustable from 0.05 to 4 In.

The negative sequence current detection thresholds are adjustable from 0.05 to 4 In.

The ground threshold of the normal range is from 0.05 to 4 In.

The ground threshold of the sensitive range is adjustable from 0.01 to 4 In.

The ground threshold of the very sensitive range is adjustable from 0.002 to 0.8 In.

The phase, ground and negative sequence current elements all have their own time delay stage settings tBF1 and tBF2. Both are adjustable from 0 to 40 s.

Warning	If these values are lower than 15 ms, there is a risk of maloperation because the disappearance of current cannot be detected in less than 15 ms. If delay tBF2 is lower than tBF1, the message Configuration problem (Setting Pb.xxx) is displayed. The protection function will not be valid and the other logic outputs will be null.
----------------	-------------------------------------------------------------------------------------------------------------------------------------------------------------------------------------------------------------------------------------------------------------------------------------------------------------------------------------------------

When energized, the CB Unhealthy input can be used to bypass the existing time delay and accelerate CBF tripping. It also has its own time delay settings tBF1 and tBF2, adjustable from 0 to 40 s. However in this application, tBF2 is set to less than tBF1 to accelerate a back-tripping of upstream circuit breakers.

3.1.3 Logical Outputs

This Breaker Fail protection will generate the following logic outputs:

Logic output	Assignable to Trip Command	Assignable to Output	Assignable to LED
t Phase A Stage1	•	•	•
t Phase B Stage1	•	•	•
t Phase C Stage1	•	•	•
t Earth Stage1	•	•	•
t Stage1	•	•	•
t Stage2	•	•	•
t Neg. Stage1	•	•	•
Phase Non I Stage1	•	•	•
Earth Non I Stage1	•	•	•
Neg. Non I Stage1	•	•	•
Non I Stage1	•	•	•
Non I Stage2	•	•	•
CB Unh. Stage1	•	•	•
CB Unh. Stage2	•	•	•

Table 1 - Logic output for breaker fail protection

3.2 End Fault Protection (Dead Zone Protection)

3.2.1 Function

The End Fault Protection function protects the section between the CT and the circuit breaker, or the section between the CT and the isolator if the circuit breaker or the isolator is open.

3.2.2 Configuration

When the End Fault Protection function is not validated by programming, all the logic outputs are Null.

If none of the logic inputs are configured on 52a or 52b and if the protection is validated, the message **Setting Pb. DZ** will be displayed. The protection function will not be valid and other logic outputs will be null.

3.2.3 Outputs

The End Fault Protection function generates three logic outputs:

- Configuration problem: Setting Pb. DZ
- Instantaneous Dead Zone start: Inst. DZ
- Time delayed Dead Zone trip: t DZ
- The time delayed Dead Zone trip signal “t DZ” can be assigned to Trip Command, Output Relays and LEDs.

3.3 Pole Discrepancy

3.3.1 Function

The pole discrepancy function uses the value of the phase currents.

3.3.2 Configuration

When the pole discrepancy function is not validated by programming, all the logic outputs are null.

If the threshold hysteresis of [I PD >] is lower than the threshold hysteresis of [I PD <] and if the protection is validated, the message **Setting Pb. PD** is displayed. Protection will not be valid and the other logic outputs will be null.

3.3.3 Logic Outputs

The pole discrepancy function generates three logic outputs:

- Configuration Problem: Setting Pb. PD
- Instantaneous Pole Discrepancy start: Inst. PD
- Time delayed Pole Discrepancy trip: t PD
- The time delayed Pole Discrepancy trip signal "t PD" can be assigned to Trip Command, Output Relays and LEDs.

3.4 Auxiliary Timers

3.4.1 Function

Two auxiliary timers tAux1 and tAux2 are available associated to Aux1 and Aux2 logic inputs. When these inputs are energised the associated timers start; after the set time the output relays associated to the timer close. The time delays are independently settable from 0 ms to 200 s. Aux1 and Aux2 can also be assigned as inputs to logic Equations.

3.4.2 Configuration

Refer to the AUTOMAT. CRTL/INPUTS menu.

3.4.3 Function

This function generates two logic outputs tAux 1 and tAux 2.

3.4.4 Outputs

Relays associated with the logic outputs.

3.5 Wiring Security

This security function is recommended but is not compulsory.

3.5.1 Function

This function protects the trip circuit against the short-circuiting of an output relay. If a de-energised relay is short-circuited, this function prevents a spurious trip. This protection function uses the redundancy of the tripping order.

3.5.2 Configuration

The wiring security function must be validated.

The relay numbers for security 1 and 2 must be configured in the wiring security function.

An opto input must be configured as security 1 (secu. 1).

An opto input must be configured as security 2 (secu. 2).

3.5.3 Automation

If the relay security 1 or the relay security 2 are polarised and the associated order is not sent, the protection is definitely put out of service. The relays are then not commanded and the watchdog is set to 0.

<i>Note</i>	<i>To set the protection back into service, the auxiliary power must be disconnected.</i>
-------------	-------------------------------------------------------------------------------------------

The relay order is delayed by 40 ms at drop off (very fast internal logic), to allow the opto input to detect the opening of the relay after a breaker failure.

<i>Note</i>	<i>This security function checks that the relay is not closed when there is no trip order. However, it does not check that the relay is correctly ordered when a trip command has been sent.</i>
-------------	--------------------------------------------------------------------------------------------------------------------------------------------------------------------------------------------------

3.5.4 Outputs

This function generates two logic outputs:

- security 1 problem,
- security 2 problem.

3.6 CB Monitoring, Control and Statistics

3.6.1 Tripping Time Supervision

The breaker tripping time is set and monitored

3.6.1.1 Configuration

Refer to the **CB SUPERVISION** menu

3.6.1.2 Function

Monitoring of the CB (CB SUPERVISION)

3.6.1.3 Outputs

This function generates two logical outputs:

- Opening time on external order (Toperating C T.Ext)
- Opening time on 1st stage order (Toperating C Stage1)

3.6.2 Number of Breaker Operations

The number of breaker operations is set and supervised. This number is incremented at each opening time (52a goes from 1 to 0, or 52b goes from 0 to 1) and is compared with the set value.

The alarm can be cleared without resetting the counter. A new alarm is then generated at the next breaker opening.

3.6.2.1 Configuration

Refer to **CB SUPERVISION** menu

3.6.2.2 Function

Monitoring of the number of breaker operations

3.6.2.3 Outputs

If the number of operations exceeds the set value, the number of operations exceeded (CB operation Nb or CB NB.op) is flagged.

3.6.3 Sum of Broken Current Squared

The sum of the broken current squared for each breaker operation is set and supervised. This number is added at each opening time (52a goes from 1 to 0, or 52b goes from 0 to 1) and is compared with the set value.

3.6.3.1 Configuration

Refer to **CB SUPERVISION** menu

3.6.3.2 Function

Monitoring of the sum of the broken current squared

3.6.3.3**Outputs**

If the broken current squared number exceeds the set value, the broken current squared exceeded signal (Sum A 2N) is flagged

3.6.4**Statistics**

The statistics function records the following events in the **EVENT COUNTERS** menu and are resettable:

- Number of tri-phase external trips
- Number of phase A external trips
- Number of phase B external trips
- Number of phase C external trips
- Number of phase A stage 1 trips
- Number of phase B stage 1 trips
- Number of phase C stage 1 trips
- Number of neutral stage 1 trips
- Number of 1st stage trips
- Number of 2nd stage trips
- Number of Negative Sequence stage 1 trips
- Number of CB Unhealthy stage 1 trips
- Number of CB Unhealthy stage 2 trips
- Number of Non-current External trips
- Number of Non-current initiated stage 1 trips by phase criterion
- Number of Non-current initiated stage 1 trips by earth criterion
- Number of Non-current initiated stage 1 trips by negative criterion
- Number of Non-current initiated stage 1 trips
- Number of Non-current initiated stage 2 trips

3.7**Blocking Logic**

Two blocking logic circuits can be assigned to opto inputs in the **AUTOMAT.CTL\BLOCKING LOGIC1/2** menu. When the relevant opto inputs are energized, the following protection functions can be blocked.

- CBF phase: Breaker Fail element works on phase current criterion
- CBF earth: Breaker Fail element works on earth current criterion
- CBF neg.: Breaker Fail element works on negative sequence current criterion
- DZ: Dead Zone protection
- PD: Pole Discrepancy protection
- tAux1
- tAux2

4 SETTING THE PROTECTION

- Set the DATE (see 6.1)
- Set the TIME (see 6.1)
- Set the DEFAULT DISPLAY (see 6.2.1)
- Set the CT RATIOS (see 6.2.2)
- Set the INPUTS (see 6.8.5)
- Configure the INPUTS (see 6.2.60)
- Set the OUTPUTS (see 6.8.3)
- Configure the OUTPUTS (see 6.8.4)
- Set the LEDs (see 6.2.3)
- [50 BF] protection (see 6.6.1)
- Select the Trip command (see 6.8.1)
- Set the kind of Trip command (see 6.8.2)
- Dead Zone protection (see 6.6.2)
- Pole discrepancy function (see 6.6.2)
- Set the CB supervision function (see 6.8.6)
- Set the Alarms (see 6.2.5)
- Set the Disturbance Recorder (see 6.9.3)

5 MENU COLUMNS

The P821 menu is divided into these columns:

Column Heading	OP Parameters	Configuration	Measurement	Event Counters	Communication	Protection G1	Protection G2	Automat. CTRL	Records
See section	See 6.1	See 6.2	See 6.3	See 6.4	See 6.5	See 6.6	See 6.7	See 6.8	See 6.9
Sub-Menus See section		Display See 6.2.1				CB Fail see 6.6.1	CB Fail see 6.6.1	Trip Command See 6.8.1	CB monitoring See 6.9.1
		CT Ratio See 6.2.2				Dead Zone See 6.6.2	Dead Zone See 6.6.2	Latch Trip Order See 6.8.2	Fault records See 6.9.2
		LED 5 to 8 See 6.2.3				Poles Discrepancy see 6.6.3	Poles Discrepancy see 6.6.3	Output Relays See 6.8.3	Disturb. Records See 6.9.3
		Group Select See 6.2.4						Latch Output Relays See 6.8.4	
		Alarms See 6.2.5						Inputs See 6.8.5	
		Inputs See 6.2.6						CB Supervision See 6.8.6	
								Wiring Security See 6.8.7	
								Blocking logic1 See 6.8.8	
								Blocking logic2 See 6.8.8	
								Logic equations See 6.8.9	

6 GENERAL SETTINGS

Throughout this section, the following sections show the HMI settings, together with a relevant description and range (where appropriate).

6.1 OP Parameters Menu

General settings and data of the relay (status of logic inputs and output relays).

Setting	Description	Range
OP PARAMETERS	Heading of the OP PARAMETERS Menu	
PASSWORD ****	Choose the password to gain access to the settings menus.	4 characters
Language = ENGLISH	Choose the HMI language.	English, Francais, Default, Chinese, Polonais, Russian, Italiano, Deutsch, Espanol
DESCRIPTION P821-1	Product description	No modification, display only
Model Number P821xxxxxxxxx	Product full code	No modification, display only
Serial Num 12345678	Product serial number	No modification, display only
REFERENCE MiCOM	Choose the plan reference-User programmable text	4 characters
SOFTWARE VERSION V10.C	Display of the software version of the product	No modification, display only
FREQUENCY 50Hz	Select the nominal value of the network frequency	50 or 60Hz
ACTIVE GROUP = 1	Choose the setting group	1 or 2
INPUT STATUS 54321 11001	Indication of the current status of all the logic inputs	No modification, display only (1 or 0)
RELAY STATUS 87654321 00111010	Indication of the current status of all the output contacts	No modification, display only (1 or 0)
DATE 01/06/10	Set the current date	1 to 31 days, 1 to 12 months, 0 to 99 years
TIME 23:03:10	Set the current time	0 to 23 hours, 0 to 59 for minutes and seconds
Disturb. Trigger No	Start a disturbance record	Yes or No

Note If any setting data exceeds the minimum or the maximum allowed value, the following message appears and the modifications are not taken into account

INCORRECT
DATA

6.2 Configuration Menu

CONFIGURATION	Heading of the CONFIGURATION menu
---------------	-----------------------------------

6.2.1 Display Sub-Menu

Select of default display and the phase labeling:

DISPLAY	Heading of the DISPLAY sub-menu
DEFAULT DISPLAY RMS IL1	Description: set the default display parameter Range: Phase A (L1, R, A), Phase B (L2, S, B), Phase C (L3, T, C), Earth (N, o, E)
PHASE A TEXT L1	Description: set the default display parameter Range: Phase A (L1, R, A)
PHASE B TEXT L2	Description: set the default display parameter Range: Phase B (L2, S, B)
PHASE C TEXT L3	Description: set the default display parameter Range: Phase C (L3, T, C)
E/GND TEXT N	Description: set the default display parameter Range: Earth (N, o, E)

6.2.2 CT Ratio Sub-Menu

Setting of the primary and the secondary rating of the current transformers

CT RATIO	Heading of the CT RATIO sub-menu
LINE CT PRIMARY 1000	Description: set the primary value of the CT phase Range: from 1 to 50000 (step 1)
LINE CT SEC. 1	Description: set the secondary value of the CT phase Range: value equals to 1 or 5
E/GND CT PRIMARY 1000	Description: set the secondary value of the CT Neutral Range: from 1 to 50000 (step 1)
E/GND CT SEC. 1	Description: set the secondary value of the CT Neutral Range: value equals to 1 or 5

6.2.3 LEDs 5 To 8 Configuration Sub-Menu

Configuration of the programmable LEDs; 36 different parameters can be assigned to each LED. The following paragraph shows the parameters for LED 5. Similar menus are available for the other LEDs.

LED 5	Heading of the LED configuration sub-menu
TRIP PHASE A EXT. NO	Description: Allocate the external trip signal on phase A to LED 5 Range: YES or NO
TRIP PHASE B EXT. NO	Description: Allocate the external trip signal on phase B to LED 5 Range: YES or NO
TRIP PHASE C EXT. NO	Description: Allocate the external trip signal on phase C to LED 5 Range: YES or NO
TRIP 3PHASES EXT. NO	Description: Allocate the three phase external trip signal to LED 5 Range: YES or NO
T PH.A STAGE1 NO	Description: Allocate the CBF stage 1 trip signal on phase A to LED 5 Range: YES or NO
T PH.B STAGE1 NO	Description: Allocate the CBF stage 1 trip signal on phase B to LED 5 Range: YES or NO
T PH.C STAGE1 NO	Description: Allocate the CBF stage 1 trip signal on phase C to LED 5 Range: YES or NO
T EARTH STAGE1 NO	Description: Allocate the CBF stage 1 trip signal on earth to LED 5 Range: YES or NO
PHASE NON I STAGE1 NO	Description: Allocate the non-current initiated CBF stage 1 trip signal on phase criterion to LED 5 Range: YES or NO
T STAGE1 NO	Description: Allocate the CBF stage 1 trip signal to LED 5 Range: YES or NO
T STAGE2 NO	Description: Allocate the CBF stage 2 trip signal to LED 5 Range: YES or NO
PROBLEM SECU1 NO	Description: Allocate the wiring security problem1 signal to LED 5 Range: YES or NO
PROBLEM SECU2 NO	Description: Allocate the wiring security problem2 signal to LED 5 Range: YES or NO
T DZ NO	Description: Allocate the Dead Zone trip signal to LED 5 Range: YES or NO
T PD NO	Description: Allocate the Pole Discrepancy trip signal to LED 5 Range: YES or NO
T Aux1 NO	Description: Allocate the delayed signal Aux1 to LED 5 Range: YES or NO
T Aux2 NO	Description: Allocate the delayed signal Aux2 to LED 5 Range: YES or NO

CB OPEN EXT. NO	Description: Allocate the signal Trip operating time too long to LED 5 Range: YES or NO
CB OPEN ST.1 NO	Description: Allocate the signal Stage1 trip operating time too long to LED 5 Range: YES or NO
CB NB OP NO	Description: Allocate the signal Number of operation exceeded to LED 5 Range: YES or NO
SUM A N NO	Description: Allocate the signal Summation of Amp (or Amp squared) cut to LED 5 Range: YES or NO
EARTH NON I STAGE1 NO	Description: Allocate the non-current initiated CBF stage 1 trip signal on earth criterion to LED 5 Range: YES or NO
NEG. NON I STAGE1 NO	Description: Allocate the non-current initiated CBF stage 1 trip signal on negative sequence current criterion to LED 5 Range: YES or NO
T NEG. STAGE1 NO	Description: Allocate the CBF stage 1 trip signal on negative sequence to LED 5 Range: YES or NO
NON I STAGE1 NO	Description: Allocate the non-current initiated CBF stage 1 trip signal to LED 5 Range: YES or NO
CB UNH. STAGE1 NO	Description: Allocate the CBF stage 1 trip signal by CB unhealthy logic to LED 5 Range: YES or NO
CB UNH. STAGE2 NO	Description: Allocate the CBF stage 2 trip signal by CB unhealthy logic to LED 5 Range: YES or NO
T EQU. A NO	Description: Allocate the output of Boolean equation A to LED 5 Range: YES or NO
T EQU. B NO	Description: Allocate the output of Boolean equation B to LED 5 Range: YES or NO
T EQU. C NO	Description: Allocate the output of Boolean equation C to LED 5 Range: YES or NO
T EQU. D NO	Description: Allocate the output of Boolean equation D to LED 5 Range: YES or NO
T EQU. E NO	Description: Allocate the output of Boolean equation E to LED 5 Range: YES or NO
T EQU. F NO	Description: Allocate the output of Boolean equation F to LED 5 Range: YES or NO
T EQU. G NO	Description: Allocate the output of Boolean equation G to LED 5 Range: YES or NO
T EQU. H NO	Description: Allocate the output of Boolean equation H to LED 5 Range: YES or NO
NON I STAGE2 NO	Description: Allocate the non-current initiated CBF stage 2 trip signal to LED 5 Range: YES or NO

Note For security problem options, see the application guide.

6.2.4 Group Select Sub-Menu

This submenu allows the user to select the active setting group (1 or 2). By default the active setting group is 1.

A logic input configured with **CHANGE SETTING** is used to change the setting group.

When **INPUT** mode is selected, the setting group can only be changed if authorised by the logic input. The setting group cannot be changed by the front panel or through the rear comms ports.

Select **MENU** mode to change the setting group using the front panel or the rear comms port.

GROUP SELECT	Heading of the Configuration Selection sub-menu
CHANGE GROUP MENU	Description: Select the operation mode of change of the active group Range: MENU or Input Note: MENU allows configuration using the front panel or rear communications port.
SETTING GROUP 1	Description: Select the active setting group Range: 1 or 2 Note: this message only appears if CHANGE GROUP then MENU are selected.

6.2.5 Alarms Sub-Menu

ALARMS

Heading of the ALARMS sub-menu

INST. SELF-RESET
Yes

Description: Select the Instantaneous Alarm Self Reset mode
Range: YES or NO

6.2.6 Configuration Inputs Sub-Menu

Logic input configuration; select the voltage type applied to the logic inputs.

INPUTS

Heading of the configuration of the INPUTS sub-menu

INPUTS: 54321
11111

Description: Select the type of the logic inputs pick up
Range: 1 (pick-up when voltage applied) or 0 (drop-off when voltage applied)

VOLTAGE INPUTS
DC

Description: Select the type of voltage applied to the logic inputs
Range: DC or AC

6.2.7 Date Format Sub-Menu

Only available on non Modbus communications relays for relay synchronisation.

DATE FORMAT

Heading of the DATE FORMAT sub-menu

Date format
PRIVATE

Description: Select the mode of the date format for synchronisation
Range: PRIVATE or IEC

6.3 Measurement Menu

Directly measured values (True RMS)

MEASUREMENT	Heading of the MEASUREMENT menu
FREQUENCY = XX.XX HZ	Description: Display the value of the network frequency calculated from the phase currents. Note If the frequency is less than 10% of the nominal value, it can not be measured and the display is XX.XX.
IL1 = 0.00 A	Description: Display the phase A current (True RMS value)
IL2 = 0.00 A	Description: Display the phase B current (True RMS value)
IL3 = 0.00 A	Description: Display the phase C current (True RMS value)
IN = 0.00 A	Description: Display the phase C current (True RMS value)
I2 = 0.00 A	Description: Display the negative sequence current

6.4 Event Counters Menu

Number and type of trips or trip orders.

EVENT COUNTERS	Heading of the Statistics Menu
RESET COUNTERS RST=[C]	Description: Reset all the counters when the key Ⓢ is pressed.
EXT TRIP 3PH. NB. -	Description: Number of three phase external trips received by the associated logic input
EXT TRIP PH A NB. -	Description: Number of phase A external trips received by the associated logic input
EXT TRIP PH B NB. -	Description: Number of phase B external trips received by the associated logic input
EXT TRIP PH C NB. -	Description: Number of phase C external trips received by the associated logic input
TRIP PH.A STAGE1 NB. -	Description: Number of phase A trip orders sent by the relay after tBF1 has expired
TRIP PH.B STAGE1 NB. -	Description: Number of phase B trip order sent by the relay after tBF1 has expired
TRIP PH.C STAGE1 NB. -	Description: Number of phase C trip orders sent by the relay after tBF1 has expired

TRIP EARTH ST.1 NB. -	Description: Number of earth trip orders sent by the relay after tBF1 has expired
TRIP STAGE 1 NB. -	Description: Number of trip orders sent by the relay after tBF1 has expired
TRIP STAGE 2 NB. -	Description: Number of trip orders sent by the relay after tBF2 has expired
TRIP NEG. ST.1 NB. -	Description: Number of negative sequence trip orders sent by the relay after tBF1 has expired
TRIP CB UNH. STG1 NB. -	Description: Number of trip orders sent by CB unhealthy logic stage1
TRIP CB UNH. STG2 NB. -	Description: Number of trip orders sent by CB unhealthy logic stage2
EXT. NON I TRIP NB. -	Description: Number of external non-current trip orders received by the associated logic input
TRIP PHASE NON I STG1NB. -	Description: Number of non-current initiated CBF stage 1 trip orders on phase criterion
TRIP EARTH NON I STG1NB. -	Description: Number of non-current initiated CBF stage 1 trip orders on earth criterion
TRIP NEG. NON I STG1NB. -	Description: Number of non-current initiated CBF stage 1 trip orders on negative sequence criterion
TRIP NON I STG1 NB. -	Description: Number of non-current initiated CBF stage 1 trip orders
TRIP NON I STG2 NB. -	Description: Number of non-current initiated CBF stage 2 trip orders

6.5 Communication Menu

Setting the protocol parameters

The COMMUNICATION menu depends on which protocol is used through the RS485 rear comms port. This protocol must be selected when ordering the relay. The choices are: MODBUS, K bus/Courier, IEC60870-5-103 and DNP3.

COMMUNICATION	Heading of the COMMUNICATION menu
COMMUNICATION YES	Description: Enable / disable the communication function Range: YES/ NO
BAUD RATE 19200 Bd	Description: Select the baud rate Range: 300/600/1200/2400/4800/9600/19200/38400.
PARITY WITHOUT	Description: Select the parity Range: WITHOUT/EVEN/ODD
STOP BITS 1	Description: Select the number of stop bits Range: 1 or 2
RELAY ADDRESS 1	Description: Select the relay address Range: from 1 to 255

Note *All the above parameters are invisible if COMMUNICATION is disabled. Parameter appearance depends on the chosen protocol.*

6.6 Protection G1 Menu

Two independent protection groups (G1 and G2) are available in the MiCOM P821.

PROTECTION G1	Heading of the protection G1 menu
---------------	-----------------------------------

6.6.1 Circuit Breaker Failure Protection Function [50BF] Sub-Menu

Submenu of the Circuit Breaker failure function

CB FAIL	Heading of the Circuit Breaker Failure protection function sub-menu
CB FAIL FUNCT. No	Description: Enable or disable the Circuit Breaker Failure protection. Range: YES or NO
Ext Non I Reset By Current	Description: Choose the reset criterion for non-current initiated CBF. Range: Current or CB Open or Cur.&CBOP (current & CB open)
CB FAIL PHASE No	Description: Enable or disable the Circuit Breaker Failure phase current criterion. Range: YES or NO
I < BF 0.1 I _n	Description: Select the phase current threshold. Range: From 0.05 to 4I _n , step of 0.01I _n
t Phase stage1 10 ms	Description: Select the time delay for stage 1 of the phase current threshold. Range: From 0 to 40 s, step of 0.005 s
t Phase stage2 40 ms	Description: Select the time delay for stage 2 of the phase current threshold. Range: From 0 to 40 s, step of 0.005 s Note: The minimum value should be the CB operating time + 20 ms + tBF1.
CB FAIL EARTH No	Description: Enable or disable the Circuit Breaker Failure earth current criterion. Range: YES or NO
I _e < BF 0.05 I _{en}	Description: Select the earth current threshold. Range: N: 0.05 I _n to 4 I _n , in steps of 0.01 I _n S: 0.01 to 4 I _n , in steps of 0.01 I _n VS: 0.002 to 0.8 I _n , in steps of 0.001 I _n
t Earth stage1 10 ms	Description: Select the time delay for stage 1 of the earth current threshold. Range: From 0 to 40 s, step of 0.005 s
t Earth stage2 40ms	Description: Select the time delay for stage 2 of phase current threshold. Range: From 0 to 40 s, in steps of 0.005 s
CB FAIL Neg. Seq No	Description: Enable or disable the Circuit Breaker Failure negative sequence current criterion. Range: YES or NO
I ₂ < BF 0.05 I _n	Description: Select the negative sequence current threshold. Range: 0.1 I _n to 4 I _n , in steps of 0.01 I _n
t Neg. stage1 10 ms	Description: Select the time delay for stage 1 of negative sequence current threshold. Range: From 0 to 40 s, in steps of 0.005 s
t Neg. stage2 40 ms	Description: Select the time delay for stage 2 of negative sequence current threshold. Range: From 0 to 40 s, in steps of 0.005 s

CB Unhealthy No	Description: Enable or disable the Circuit Breaker Failure CB unhealthy logic. Range: YES or NO
t Unh. stage1 500 ms	Description: Select the time delay for stage 1 of CB unhealthy logic. Range: From 0 to 40 s, in steps of 0.005 s
t Unh. Stage2 0 ms	Description: Select the time delay for stage 2 of CB unhealthy logic. Range: From 0 to 40 s, in steps of 0.005 s
External reset No	Description: Enable or disable the external reset mechanism of Circuit Breaker Failure logic. Range: YES or NO

6.6.2 Dead Zone Protection Function Sub-Menu

Submenu of the Dead Zone protection function

HMI description:

DEAD ZONE	Heading of the DEAD ZONE function sub-menu
DEAD ZONE PROT. No	Description: Enable or disable the Dead Zone protection. Range: YES or NO
I DZ> 1.0 In	Description: Select the phase current threshold. Range: From 0.05 to 4 In, in steps of 0.01 In
Ie DZ> 0.05 Ien	Description: Select the earth current threshold. Range: N: 0.05 In to 4 In, in steps of 0.01 In S: 0.01 to 4 In, in steps of 0.01 In VS: 0.002 to 0.8 In, in steps of 0.001 In
t DZ 100 ms	Description: Dead Zone delay. Range: From 0 ms to 40 s, in steps of 0.005 s Note: The minimum value should be the CB operating time + 20 ms.

6.6.3 Poles Discrepancy Function Sub-Menu

Submenu of the Pole Discrepancy protection function:

POLE DISCREPANCY	Heading of the Pole Discrepancy function sub-menu
POLE DISCREPANCY FUNCT. No	Description: Enable or disable the pole discrepancy function. Range: YES or NO
I PD> 0.8 In	Description: Select the overcurrent threshold. Range: From 0.05 to 4 In, step of 0.01 In
I PD< 0.4 In	Description: Select the undercurrent threshold. Range: From 0.05 to 4 In, step of 0.01 In
t PD 100 ms	Description: Pole discrepancy delay. Range: From 0 ms to 40 s, in steps of 0.005 s Note: The minimum value should be the CB operating time + 20 ms.

6.7 Protections (G2) Menu

As paragraph 6.6 for group 2.

6.8 Automatic Ctrl Menu

AUTOMAT . CTRL	Heading of the AUTOMATIC CTRL menu
----------------	------------------------------------

6.8.1 Trip Command Sub-Menu

Concerns relay 1 only:

TRIP COMMAND	Heading of the TRIP COMMAND sub-menu
TRIP t PH. A STAGE1 No	Description: Enable or disable the phase A trip order sent by relay 1 after tBF1 has expired Range: YES or NO
TRIP t PH. B STAGE1 No	Description: Enable or disable the phase B trip order sent by relay 1 after tBF1 has expired Range: YES or NO
TRIP t PH. C STAGE1 No	Description: Enable or disable the phase C trip order sent by relay 1 after tBF1 has expired Range: YES or NO
TRIP t EARTH STAGE1 No	Description: Enable or disable the Earth trip order sent by relay 1 after tBF1 has expired Range: YES or NO
TRIP t STAGE 1 No	Description: Enable or disable the trip order sent by relay 1 after the expiration of the tBF1 Range: YES or NO
TRIP t STAGE 2 No	Description: Enable or disable the trip order sent by relay 1 after tBF2 has expired Range: YES or NO

TRIP t DZ No	Description: Enable or disable the trip order sent by relay 1 after the Dead Zone delay has expired Range: YES or NO
TRIP t PD No	Description: Enable or disable the trip order sent by relay 1 after the Pole Discrepancy delay has expired Range: YES or NO
TRIP tAux1 No	Description: Enable or disable the trip order sent by relay 1 after the Aux1 delay has expired Range: YES or NO
TRIP tAux2 No	Description: Enable or disable the trip order sent by relay 1 after the Aux2 delay has expired Range: YES or NO
Trip Phase Non I stage1 No	Description: Enable or disable the non-current initiated CBF stage 1 trip signal on phase criterion Range: YES or NO
Trip Earth Non I stage1 No	Description: Enable or disable the non-current initiated CBF stage 1 trip signal on earth criterion Range: YES or NO
Trip Neg. Non I stage1 No	Description: Enable or disable the non-current initiated CBF stage 1 trip signal on negative sequence current criterion Range: YES or NO
Trip t Neg. stage1 No	Description: Enable or disable the Negative Current trip order sent by the relay after tBF1 has expired Range: YES or NO
Trip Non I stage1 No	Description: Enable or disable the non-current initiated CBF stage 1 trip signal Range: YES or NO
Trip CB Unh. stage1 No	Description: Enable or disable the CBF stage 1 trip signal from the CB unhealthy logic Range: YES or NO
Trip CB Unh. Stage2 No	Description: Enable or disable the CBF stage 2 trip signal from the CB unhealthy logic Range: YES or NO
Trip Equation A No	Description: Enable or disable trip order output from Boolean logic A Range: YES or NO
Trip Equation B No	Description: Enable or disable trip order output from Boolean logic B Range: YES or NO
Trip Equation C No	Description: Enable or disable trip order output from Boolean logic C Range: YES or NO
Trip Equation D No	Description: Enable or disable trip order output from Boolean logic D Range: YES or NO
Trip Equation E No	Description: Enable or disable trip order output from Boolean logic E Range: YES or NO
Trip Equation F No	Description: Enable or disable trip order output from Boolean logic F Range: YES or NO
Trip Equation G No	Description: Enable or disable trip order output from Boolean logic G Range: YES or NO
Trip Equation H No	Description: Enable or disable trip order output from Boolean logic H Range: YES or NO
Trip Non I stage2 No	Description: Enable or disable the non-current initiated CBF stage 2 trip signal Range: YES or NO

6.8.2 Latch Trip Order Sub-Menu

Concerns relay 1 only.:

LATCH TRIP ORDER	Heading of the LATCH TRIP ORDER sub-menu
LATCH t PH. A STAGE1 No	Description: Latch the phase A trip order sent by relay 1 after tBF1 has expired Range: YES / NO
LATCH t PH. B STAGE1 No	Description: Latch the phase B trip order sent by relay 1 after tBF1 has expired Range: YES / NO
LATCH t PH. C STAGE1 No	Description: Latch the phase C trip order sent by relay 1 after tBF1 has expired Range: YES / NO
LATCH t EARTH STAGE1 No	Description: Latch the earth trip order sent by relay 1 after tBF1 has expired Range: YES / NO
LATCH t STAGE1 No	Description: Latch the trip order sent by relay 1 after tBF1 has expired Range: YES / NO
LATCH t STAGE2 No	Description: Latch the trip order sent by relay 1 after tBF2 has expired Range: YES / NO
LATCH t DZ No	Description: Latch the trip order sent by relay 1 after the Dead Zone delay has expired Range: YES / NO
LATCH t PD No	Description: Latch the trip order sent by relay 1 after the Pole Discrepancy delay has expired Range: YES / NO
LATCH tAux1 No	Description: Latch a trip order sent by relay 1 after the Aux1 delay has expired Range: YES / NO
LATCH tAux2 No	Description: Latch a trip order sent by relay 1 after the Aux2 delay has expired Range: YES / NO
Latch Ph Non I stage1 No	Description: Latch the non-current initiated CBF stage 1 trip signal on phase criterion Range: YES or NO
Trip Ea Non I stage1 No	Description: Latch the non-current initiated CBF stage 1 trip signal on earth criterion Range: YES or NO
Latch Ne Non I stage1 No	Description: Latch the non-current initiated CBF stage 1 trip signal on negative sequence current criterion Range: YES or NO
Latch tNeg. stage1 No	Description: Latch the Negative Current trip order sent by the relay after tBF1 has expired Range: YES or NO
Latch Non I stage1 No	Description: Latch the non-current initiated CBF stage 1 trip signal Range: YES or NO
Latch CB Unh. stage1 No	Description: Latch the CBF stage 1 trip signal from the CB unhealthy logic Range: YES or NO
Latch CB Unh. Stage2 No	Description: Latch the CBF stage 2 trip signal from the CB unhealthy logic Range: YES or NO
Latch Non I stage2 No	Description: Latch the non-current initiated CBF stage 2 trip signal Range: YES or NO

6.8.3 Output Relays Sub-Menu

Configuration of auxiliary output relays; 8 output relays are available in the MiCOM P821. 7 output contacts can be configured with several options. The Relay 1 is described in section 0.:

OUTPUT RELAYS	Heading of the OUTPUT RELAYS sub-menu
T PH.A STAGE1 8765432 0000000	Description: Allocate the stage 1 trip order on phase A to the output contacts Range: 0 or 1
T PH.B 8765432 STAGE1 0000000	Description: Allocate the stage 1 trip order on phase B to the output contacts Range: 0 or 1
T PH.C 8765432 STAGE1 0000000	Description: Allocate the stage 1 trip order on phase C to the output contacts Range: 0 or 1
T EARTH 8765432 STAGE1 0000000	Description: Allocate the stage 1 trip order on the Earth to the output contacts Range: 0 or 1
Ph Non I 8765432 stage1 0000000	Description: Allocate the non-current initiated CBF stage 1 trip signal on phase criterion to the output contacts Range: 0 or 1
T STAGE1 8765432 0000000	Description: Allocate the stage 1 (tBF1) trip signal to the output contacts Range: 0 or 1
TSTAGE2 8765432 0000000	Description: Allocate the stage 2 (tBF2) trip signal to the output contacts Range: 0 or 1
T DZ 8765432 0000000	Description: Allocate the Dead Zone trip information to the output contacts Range: 0 or 1
T PD 8765432 0000000	Description: Allocate the Pole Discrepancy trip information to the output contacts Range: 0 or 1
tAux1 8765432 0000000	Description: Allocate the tAux1 trip information to the output contacts Range: 0 or 1
tAux2 8765432 0000000	Description: Allocate the tAux2 trip information to the output contacts Range: 0 or 1
CB OPEN 8765432 EXT. 0000000	Description: Allocate the signal Trip operating time too long to the output contacts Range: 0 or 1
CB OPEN 8765432 ST.1 0000000	Description: Allocate the signal Stage 1 trip operating time too long signal to the output contacts Range: 0 or 1
CB NB OP 8765432 0000000	Description: Allocate the signal Number of operation exceeded to the output contacts Range: 0 or 1
Sum A n 8765432 0000000	Description: Allocate the signal Summation of Amp (or Amp squared) cut to the output contacts Range: 0 or 1
Ea Non I 8765432 stage1 0000000	Description: Allocate the non-current initiated CBF stage 1 trip signal on earth criterion to output contacts Range: 0 or 1
Ne Non I 8765432 stage1 0000000	Description: Allocate the non-current initiated CBF stage 1 trip signal on negative sequence criterion to output contacts Range: 0 or 1

t Neg. stage1	8765432 0000000	Description: Allocate the Negative Current trip order sent by the relay after tBF1 has expired Range: YES or NO
Non I stage1	8765432 0000000	Description: Allocate the non-current initiated CBF stage 1 trip signal to output contacts Range: 0 or 1
CB Unh. stage1	8765432 0000000	Description: Allocate the CBF stage 1 trip signal by CB unhealthy logic to output contacts Range: 0 or 1
CB Unh. stage2	8765432 0000000	Description: Allocate the CBF stage 2 trip signal by CB unhealthy logic to output contacts Range: 0 or 1
EQU.A	8765432 0000000	Description: Allocate the output of Boolean logic A to output contacts Range: 0 or 1
EQU.B	8765432 0000000	Description: Allocate the output of Boolean logic B to output contacts Range: 0 or 1
EQU.C	8765432 0000000	Description: Allocate the output of Boolean logic C to output contacts Range: 0 or 1
EQU.D	8765432 0000000	Description: Allocate the output of Boolean logic D to output contacts Range: 0 or 1
EQU.E	8765432 0000000	Description: Allocate the output of Boolean logic E to output contacts Range: 0 or 1
EQU.F	8765432 0000000	Description: Allocate the output of Boolean logic F to output contacts Range: 0 or 1
EQU.G	8765432 0000000	Description: Allocate the output of Boolean logic G to output contacts Range: 0 or 1
EQU.H	8765432 0000000	Description: Allocate the output of Boolean logic H to output contacts Range: 0 or 1
Non I Stage2	8765432 0000000	Description: Allocate the non-current initiated CBF stage 2 trip signal to output contacts Range: 0 or 1

6.8.4 Latch Output Relays Sub-Menu

Latching of the auxiliary relays:

LATCH OUTPUT RELAYS	Heading of the LATCH OUTPUT RELAYS sub-menu
LATCH RELAY 2 NO	Description: Select the output contact RL2 to be latched Range: YES / NO
LATCH RELAY 3 NO	Description: Select the output contact RL3 to be latched Range: YES / NO
LATCH RELAY 4 NO	Description: Select the output contact RL4 to be latched Range: YES / NO
LATCH RELAY 5 NO	Description: Select the output contact RL5 to be latched Range: YES / NO
LATCH RELAY 6 NO	Description: Select the output contact RL6 to be latched Range: YES / NO
LATCH RELAY 7 NO	Description: Select the output contact RL7 to be latched Range: YES / NO
LATCH RELAY 8 NO	Description: Select the output contact RL8 to be latched Range: YES / NO

6.8.5 Inputs Sub-Menu

Configuration of logic inputs; This sub-menu allows the user to allocate a specific function to each of the 5 logic inputs. List of available functions/information:

INPUTS	Heading of the INPUTS sub-menu
Input 1	Heading of Input 1. Press left and right key to get into other Inputs, which have the same setting option as Input 1.
Input 1 Ext.trip Ph. A No	Allocate the external trip order phase A to input 1
Input 1 Ext.trip Ph. B No	Allocate the external trip order phase B to input 1
Input 1 Ext.trip Ph. C No	Allocate the external trip order phase C to input 1
Input 1 Ext.trip 3 Ph. No	Allocate the external trip order 3 phase to input 1
Input 1 Unlatch No	Allocate unlatching of all the auxiliary relays to input 1
Input 1 52a No	Allocate auxiliary contact of the CB (1 if CB closed) to input 1

Input 1 52b No	Allocate auxiliary contact of the CB (1 if CB open) to input1
Input 1 tAux1 No	Allocate Input 1 to the time delay for input Aux1.
Input 1 tAux2 No	Allocate Input 1 to the time delay for input Aux2.
Input 1 Change setting No	Allocate Input 1 to change the active setting group
Input 1 Start Disturb No	Allocate Input 1 to external triggering of the Disturbance recorder
Input 1 Secu. 1 No	Allocate Input 1 to the Wiring Security 1 input
Input 1 Secu. 2 No	Allocate Input 1 to the Wiring Security 2 input
Input 1 LEDs reset No	Allocate the LED reset function to Input 1
Input 1 CB Unh. No	Allocate the external CB unhealthy information to Input 1
Input 1 Block Logic1 No	Allocate Input 1 to the external blocking logic 1
Input 1 Block Logic2 No	Allocate Input 1 to the external blocking logic 2
Input 1 SYNCHRO No	Allocate the external time synchronizing signal to Input 1
Input 1 Ext.Trip Non I No	Allocate the external non-current trip order to Input 1
Aux. Times	Heading of auxiliary timers
tAux 1 0ms	Description: Select the time delay for Aux1 Range: From 0 to 200s, step of 0.01s
tAux 2 0ms	Description: Select the time delay for Aux2 Range: From 0 to 200s, step of 0.01s

6.8.6 CB Supervision Sub-Menu

Configuration of the operating time, operation number, sum of cut current, opening time and closing time.:

CB SUPERVISION	Heading of the CB SUPERVISION sub-menu
CB OPENING TIME SUPERV No	Description: Enable or disable the CB opening time supervision function Range: YES / NO
CB OPENING TIME 100 ms	Description: Set the CB opening time Range: 0.1 to 5 s, in steps of 0.1 s
CB OPERATION NB SUPERV YES	Description: Enable or disable the supervision function for the CB number of operations Range: YES / NO
CB OPERATION NB 0	Description: Set the threshold for the CB number of operations already performed Range: 0 to 50000, step 1
SUM A n SUPERV YES	Description: Enable or disable the sum of cut current supervision function Range: YES / NO
SUM A n 0 E6	Description: Set the threshold for Summation of Amps (or Amps squared) already cut by the CB Range: 0 E6 to 4000 E6, step 1
N 1	Description: Select the Summation of Amp (or Amp squared) mode Range: 1 (Amp) or 2 (Amp squared)
T TRIP 100 ms	Description: Set the CB trip relay latch time Range: 0.1 to 5 s, in steps of 0.1s

6.8.7 Wiring Security Sub-Menu

HMI description:

WIRING SECURITY	Heading of the WIRING SECURITY sub-menu
WIRING SECURITY No	Description: Enable or disable the auxiliary relay supervision function Range: YES / NO
RELAY SECURITY 1 Relay1	Description: Select the auxiliary relay to be supervised Range: NONE or REL 1 to 8
RELAY SECURITY 2 Relay2	Description: Select the auxiliary relay to be supervised Range: NONE or REL 1 to 8

6.8.8 Blocking Logic1/2 Sub-Menu

Configuration of the blocking logic to block the operation of relevant protection functions.
List of available functions/information:

BLOCKING LOGIC1/2		Heading of the BLOCKING LOGIC sub-menu
Block 1 CBF phase	No	Allocate blocking logic 1 to block CBF phase current element Range: Yes / No
Block 1 CBF earth	No	Allocate blocking logic 1 to block CBF earth current element Range: Yes / No
Block 1 CBF Neg.	No	Allocate blocking logic 1 to block CBF negative sequence current element Range: Yes / No
Block 1 DZ	No	Allocate blocking logic 1 to block Dead Zone protection Range: Yes / No
Block 1 PD	No	Allocate blocking logic 1 to block Pole Discrepancy protection Range: Yes / No
Block 1 tAux1	No	Allocate blocking logic 1 to time delay for input Aux1 Range: Yes / No
Block 1 tAux2	No	Allocate blocking logic 1 to time delay for input Aux1 Range: Yes / No

6.8.9 Logic Equations Sub-Menu

With the Logic Equations submenu, up to 8 complex Boolean functions can be formed using OR, OR NOT, AND, AND NOT operators. Up to 16 operands can be used in any single equation. The following logic signals are available for mapping to an equation:

TEXT	TEXT in HMI	Information
Null	Null	None
t Ph. A stage 1	PhA St1	Stage 1 trip order on phase A
t Ph. B stage 1	PhB St1	Stage 1 trip order on phase B
t Ph. C stage 1	PhC St1	Stage 1 trip order on phase C
Earth non I stage1	Eth No1	Non-current initiated CBF stage 1 trip signal on earth criterion
t Earth stage 1	Eth St1	Stage 1 trip order on the Earth
t Neg. non I stg1	Neg No1	Non-current initiated CBF stage 1 trip signal on negative sequence criterion
t Neg. stage 1	Neg St1	Negative sequence current trip order stage 1
t Phase non I stg1	Pha No1	Non-current initiated CBF stage 1 trip signal on phase current criterion
t CB Unh. stage1	Unh st1	CBF stage 1 trip signal by CB unhealthy logic
t CB Unh. stage2	Unh st2	CBF stage 2 trip signal by CB unhealthy logic
t stage 1	Stage 1	Stage 1 trip order
t stage 2	Stage 2	Stage 2 trip order
t DZ	t DZ	Dead Zone trip order
t PD	t PD	Pole Discrepancy trip order
t Aux1	t Aux1	Auxiliary delay timer 1

TEXT	TEXT in HMI	Information
tAux2	tAux2	Auxiliary delay timer 2
CB open ext	CBO ext	CB opening time exceeds threshold
CB open st.1	CBO st1	Stage 1 tripping time exceeds threshold
CB NB. op.	CBNB op	CB operating numbers exceed threshold
Sum A n	Sum A n	Sum of cut current exceeds threshold
Input 1	Input 1	Opto input 1
Input 2	Input 2	Opto input 2
Input 3	Input 3	Opto input 3
Input 4	Input 4	Opto input 4
Input 5	Input 5	Opto input 5
t Non I stage 1	Nol st1	Non-current initiated CBF stage 1 trip signal
t Non I stage 2	Nol st2	Non-current initiated CBF stage 2 trip signal

Table 2 - Operands for Boolean equations

Example of Equation A settings for P821

AUTOMAT. CTRL	Heading of AUTOMAT. CTRL menu. To access the Logic Equations menu, press then scroll using to reach the desired submenu.
Logic Equations	Heading of Logic Equations submenu. To access the Logic Equations submenus, press then scroll using to reach the relevant Equation submenu.
Equation A.00 = Null	Heading of Equation A submenu To navigate within the submenu, press . To access the relevant operand submenu, scroll using and . To modify the setting, press . Use to scroll and set available selections. Press to confirm the selection. Setting choice: =, NOT Setting Choice: as in Table 2
Equation A.01 OR Null	Setting choice: OR, OR NOT, AND, AND NOT Setting Choice: as in Table 2
Equation A.02 OR Null	Setting choice: OR, OR NOT, AND, AND NOT Setting Choice: as in Table 2
Equation A.03 OR Null	Setting choice: OR, OR NOT, AND, AND NOT Setting Choice: as in Table 2
Equation A.04 OR Null	Setting choice: OR, OR NOT, AND, AND NOT Setting Choice: as in Table 2
Equation A.05 OR Null	Setting choice: OR, OR NOT, AND, AND NOT Setting Choice: as in Table 2
Equation A.06 OR Null	Setting choice: OR, OR NOT, AND, AND NOT Setting Choice: as in Table 2
Equation A.07 OR Null	Setting choice: OR, OR NOT, AND, AND NOT Setting Choice: as in Table 2
Equation A.08 OR Null	Setting choice: OR, OR NOT, AND, AND NOT Setting Choice: as in Table 2

Equation A.09 OR Null	Setting choice: OR, OR NOT, AND, AND NOT Setting Choice: as in Table 2
Equation A.10 OR Null	Setting choice: OR, OR NOT, AND, AND NOT Setting Choice: as in Table 2
Equation A.11 OR Null	Setting choice: OR, OR NOT, AND, AND NOT Setting Choice: as in Table 2
Equation A.12 OR Null	Setting choice: OR, OR NOT, AND, AND NOT Setting Choice: as in Table 2
Equation A.13 OR Null	Setting choice: OR, OR NOT, AND, AND NOT Setting Choice: as in Table 2
Equation A.14 OR Null	Setting choice: OR, OR NOT, AND, AND NOT Setting Choice: as in Table 2
Equation A.15 OR Null	Setting choice: OR, OR NOT, AND, AND NOT Setting Choice: as in Table 2

6.9 Records Menu

6.9.1 CB Monitoring Sub-Menu

CB MONITORING	Heading of the CB MONITORING sub-menu
CB OPENING TIME 0 ms	Description: Display the last CB opening time Range: No modification, display only
CB OPERATIONS RST=[C] 0	Description: Display the number of CB operations performed; pressing the key \odot resets the counter.
Σ AMPS(n) RST=[C]	Description: Display the Summation of Amps (or Amps squared); pressing the key \odot resets the counter.
Σ AMPS(n) IA 0 E00	Description: Display the Summation of Amps (or Amps squared) cut on phase A
Σ AMPS(n) IB 0 E00	Description: Display the Summation of Amps (or Amps squared) cut on phase B
Σ AMPS(n) IC 0 E00	Description: Display the Summation of Amps (or Amps squared) cut on phase C

6.9.2 Fault Record Sub-Menu

Visualisation of the last 25 faults:

FAULT RECORD	Heading of the FAULT RECORD sub-menu
RECORD NUMBER 25	Description: Display the number of the record to view
FAULT TIME **:**:**:**	Description: Display the fault time of the selected record Range: 0-23 for hours, 0-59 for minutes and seconds.
FAULT DATE **/**/**	Description: Display the fault date of the selected record Range: 1-31 for days, 1-12 for months, 0-99 for years
ACTIVE SET GROUP *	Description: Display the setting group set for the selected record
FAULTED PHASE NONE	Description: Display the faulted phase of the selected record
THRESHOLD NONE	Description: Display the fault threshold of the selected record
MAGNITUDE xxxxxx	Description: Display the fault current magnitude of the selected record
IA MAGNITUDE xxxx	Description: Display the fault current phase A magnitude of the selected record
IB MAGNITUDE xxxx	Description: Display the fault current phase B magnitude of the selected record
IC MAGNITUDE xxxx	Description: Display the fault current phase C magnitude of the selected record
IE MAGNITUDE xxxx	Description: Display the fault earth current magnitude of the selected record

6.9.3 Disturbance Record Sub-Menu

Configuration of disturbance records:

DISTURB. RECORD	Heading of the DISTURBANCE RECORD sub-menu
PRE - TIME 0.1s	Description: Setting of the pre-trigger time Range: 0.1 to 9 s, in steps of 0.1 s
DISTURB REC TRIG ON TRIP	Description: Select the trigger mode Range: ON TRIP / ON INST.

7 WIRING

The MiCOM Px20 relays all have the same cable layout for common elements.

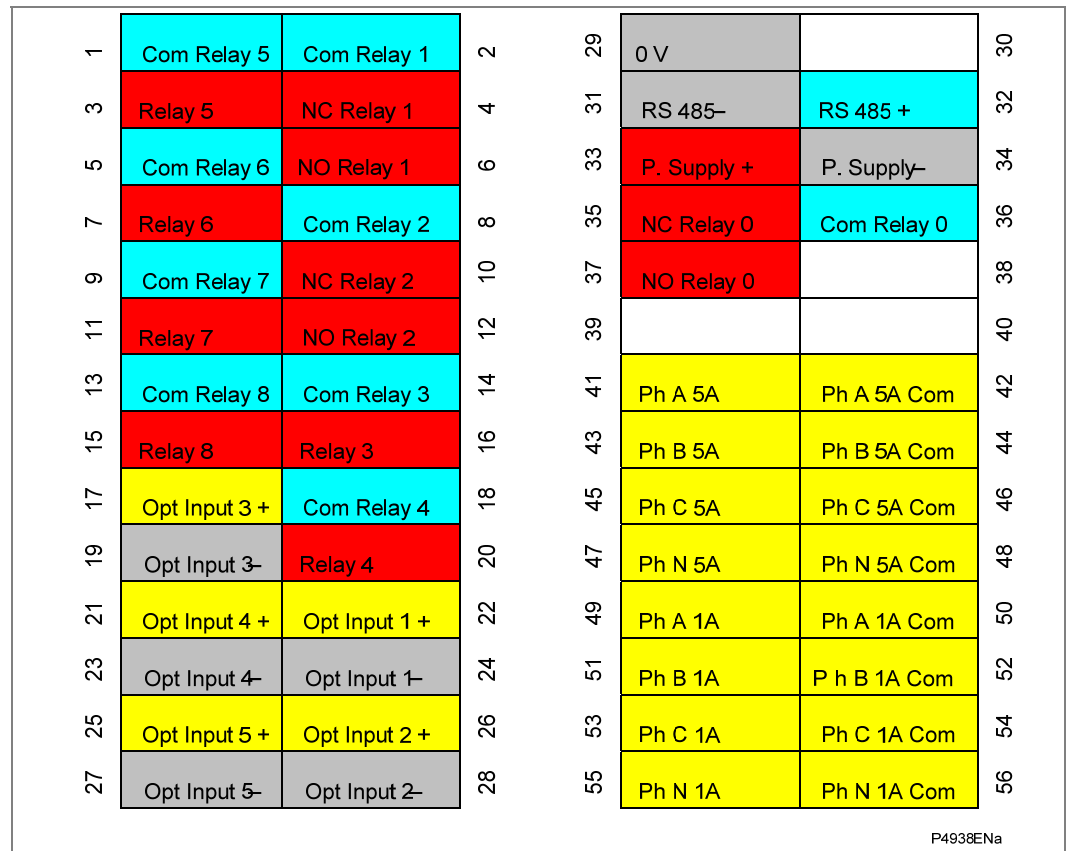

Figure 4 - Rear connectors

7.1 Auxiliary Supply

The auxiliary power supply can be either DC (range 24-250 Vdc, 48-250 Vdc) or AC (48-240 Vac / 50-60 Hz).

The voltage range is specified on the relay data plate under the upper flap on the front face. The supply must only be connected to terminals 33 and 34.

7.2 Current Measurement Inputs

The MiCOM P821 has eight current inputs (two sets of four earth and phase current inputs).

The nominal current of these measuring inputs is either 1 A or 5 A depending on the cabling layout. For the same relay, the user can mix the 1 A and 5 A inputs between phases and earth.

Note All two or three phase inputs must have the same value (1 A or 5 A)

7.3 Logic Inputs

The MiCOM P821 has five opto-isolated logic inputs. Each input has its own independent polarity.

The voltage range of the inputs is identical to the dc or ac auxiliary supply range of the MiCOM relay (e.g. Uaux = 24-250 Vdc, logic input voltage range = 24-240 Vac).

The user can mix different voltage levels for the logic inputs (e.g. Uaux = 48-150 Vdc, Input 1= 48 Vdc, Input 2-5= 110 Vdc)The automation operations and signalling functions to which these logic inputs respond can be selected from the **AUTOMAT. CTRL** Menu.

Note In the **CONFIGURATION / Configuration Inputs** menu, select the input voltage as **AC** or **DC**.

7.4 Output Relays

The MiCOM P821 has nine output relays, eight of which are freely programmable.

The first relay with a change-over contact (RL0) is allocated to signalling an equipment fault (WATCHDOG).

The second and third relays (RL1 & RL2) are changeover relays (1 common, 1 Normally Open (NO) contact, 1 Normally Closed (NC) contact).

The other relays (RL3, to RL 8) are Normally Open relays (1 common, 1 open contact). The protection and control functions that can be assigned to these output relays can be selected from the **AUTOMAT. CTRL** menu.

7.5 Communication

7.5.1 RS485 Rear Communications Port

All MiCOM relays have an RS485 rear communications port. Communication connections are allocated to terminals 29-30-31-32.

7.5.2 RS232 Front Communication Port:

The MiCOM P821 has an RS232 communications port on the front panel under the lower flap. This port is intended for use with a PC running MiCOM S1 or MiCOM S1 Studio setting software.

The cable between the P821 and the PC is a standard RS232 shielded-cable. A USB to RS232 cable can also be used.

The P821 requires a 9-pin male connector and the cable must be wired as follows.

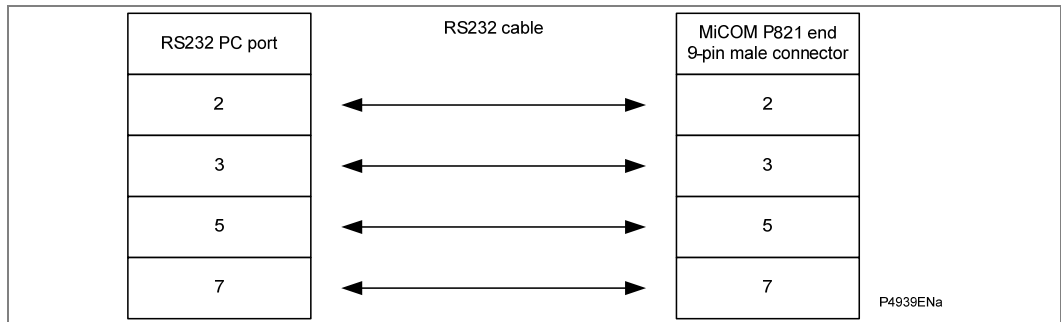

Figure 5 - RS232 front port communication cable wiring

7.6 Password

Warning Once the password is entered, settings cannot be changed using the RS232 or RS485 communications ports.

7.6.1 Password Protection

Password protection is required for relay settings, especially when changing the various thresholds, time delays, communication parameters, allocation of inputs and outputs relays.

The password consists of four upper case characters. When leaving the factory, the password is AAAA. but is user-definable using any combination of four characters.





If the password is lost or forgotten, contact the manufacturer or a representative, specifying the relay's serial number. An emergency password specific to the relay can then be supplied.

Notes The programming mode is indicated with the letter **P** on the bottom right of the display on each menu heading. The letter **P** is present as long as the password is active (5 minutes if no key is pressed).

Warning Once the password is entered, settings cannot be changed using the RS232 or RS485 communications ports.

7.6.2 Entering the Password

The password is requested as soon as a parameter is modified for any one of the menus or submenus.



To enter a password, select letters of the alphabet using  . After each letter, press  to enter the next letter. Press  to confirm the password.

If the password is correct, **PASSWORD OK** appears on the screen. The default factory password is AAAA.

After 5 seconds, the display returns to the point of the preceding menu.

If no key is pressed within 5 minutes, the password is deactivated. A new password is requested each time a subsequent parameter needs to be modified.

7.6.3 Changing the Password

To change an active password, select the **OP. PARAMETERS** menu then the **Password** submenu. Enter the current password and press , then enter the new password and press .

The message **NEW PASSWORD OK** is appears when the new password is accepted.

7.7

Alarm Display

Two alarm messages have been introduced:

DEFAULT SETTINGS: Each time the relay is powered ON it will check its memory contents to determine whether the settings are set to the factory defaults. If the relay detects that the default settings are loaded an alarm is raised.

A "HARDWARE " ALARM will appear on the LCD display. Pressing the  button will cause **DEFAULT SETTINGS** message to be displayed. In addition,

- the ALARM LED (YELLOW) will light up
- the Watch Dog contact will be activated

Only one parameter in the relay's menu needs to be changed to suppress these messages and to reset the watchdog.

This alarm is only an indication to the user that the relay has its default settings applied. When the firmware is downloaded into the relay, this will load the default settings and the relay will, therefore, display this alarm. Changing one of the setting values will allow this alarm to be cleared.

SETTING ERROR: Should the CPU fails to get correctly store data to the EEPROM during a setting change, a "HARDWARE" ALARM will appear on the LCD display followed by "**SETTING ERROR**" message (when pushing on the  button). In addition,

- the ALARM LED (YELLOW) will light up
- the Watch Dog contact will be activated

To reset this alarm it is necessary to power ON and OFF the relay. Following this, the last unsuccessful setting change will then need to be re-applied. If the alarm persists, i.e. the "SETTING ERROR" alarm is still displayed, please contact Schneider Electric After Sales Services for advice and assistance.

The management of alarms is directly displayed on the LCD. The display of alarm messages has priority over the default current value. As soon as an alarm is detected by the relay (threshold crossing for example), the message is displayed on the MiCOM LCD display and the Alarm LED (2nd LED) lights up.

The alarm messages are classed as follows:

- Electrical power network alarm message
- Hardware or software fault message from the relay.



7.7.1

Electrical System Alarms

Any crossing of a threshold (instantaneous or delay) generates an "electrical network alarm". For each threshold the involved threshold is indicated. Regarding the phase threshold, the phase (A, B or C) is also displayed.

If several alarms are triggered, they are all stored in their order of appearance the most recent alarm first, the oldest alarm last. Each message is numbered and the total of messages is shown.

The user read all the alarm messages using  without entering the password.

The user acknowledges the alarms using , but must enter the password. The user can acknowledge each message one by one or all by going to the end of the list and acknowledge all the messages using .

The management of the ALARM LED is directly linked to the status of the stored alarms.

- If one or several messages are NOT READ and NOT ACKNOWLEDGED, the alarm LED flashes.
- If all the messages have been READ but NOT ACKNOWLEDGED, the alarm LED remains lights up continuously.
- If all the messages have been READ and ACKNOWLEDGED, the alarm LED goes out.

Notes *The alarms concerning the instantaneous can be selected self reset Yes or No in the CONFIGURATION/Alarms Menu*
The reset of the relay latched is described in the sub-menu content description.

The different electrical systems alarms are described below:

First stage BF phase A,	t Phase A Stage 1	
First stage BF phase B,	t Phase B Stage 1	
First stage BF phase C,	t Phase C Stage 1	
First stage BF Earth,	t Earth Stage 1	
First stage BF,	t Stage 1	
Second stage BF,	t Stage 2	
Configuration delay Problem tBF (automatic reset)		Setting PB tStage 1
Problem security 1	Security 1 PB	
Problem security 2	Security 2 PB	
Problem security configuration	Setting PB Secu	
Aux1 time-out	tAux1	
Aux2 time-out	tAux2	
Dead Zone trip	tDZ	
Dead Zone pick up	Inst.DZ	
Problem configuration Dead Zone protection (self reset)		Setting PB DZ
Pole Discrepancy trip	tPD	
Poles Discrepancy pick up	Inst.PD	
Problem configuration Poles Discrepancy (self reset)		Setting PB PD
LATCH RELAY	A least one auxiliary relay is latched.	
LATCH RELAY TRIP	The relay trip is latched.	
T operating CB	Operating (or tripping) time of the circuit breaker longer than the value set in the AUTOMAT. CTRL/CB Supervision menu.T Ext Stage1	
CB OPEN NB	Number of circuit breaker operation higher that the value set in the AUTOMAT. CTRL/CB Supervision menu.	
Sum An	Broken current measured higher than the value set in the AUTOMAT.CTRL/CB Supervision menu.	

7.7.2 Relay Hardware or Software Alarms

Any software or hardware fault of the MiCOM relay generates a "hard/software alarm". If several alarms are acquired they are all stored in their order of appearance. Alarms are displayed in reverse order with the most recent first. Each message is numbered and the total stored is shown.

The user can read all the alarm messages by pressing the read key , without entering the password.

It is not possible to acknowledge and clear relay alarm messages. Only the disappearance of the cause resets the alarm. Alarms can only be cleared once the cause of the hardware or software failure has been removed.

The management of the WARNING LED is directly linked to the status of the alarms stored in memory.

- If the fault is major, and the relay cannot perform protection functions, the WARNING LED switches ON continuously.
- If the fault is minor and there is no influence on the protection and automation function, such as a communication failure, the WARNING LED flashes.

Possible Hardware or Software alarm messages:

7.7.2.1 Major Fault

The protection and automation functions are stopped.

The RL0 watchdog relay is de-energised (35-36 contact closed).

<<EEPROM ERROR CALIBR.>>: Calibration zone in fault

<<CT ERROR>>: Analogue channel in fault

7.7.2.2 Minor Fault

The MiCOM relay is fully operational.

The RL0 watchdog relay is energised (35-36 contact open, 36-37 contact closed).

<<RAM ERROR>>: RAM powered by faulty battery.

<<COMM.ERROR>>: Communication fault

<<CLOCK ERROR>>: Date and time error

MENU CONTENT DIAGRAMS

CHAPTER 4

Date (month/year)	02/2016
Software Version	10.E
Hardware Suffix	Phase 2
Serial Number	Hardware installed

CONTENTS

Page (HI) 4-

1 MiCOM P821 Software (Version 10)

5

Notes:

1 MICOM P821 SOFTWARE (VERSION 10)

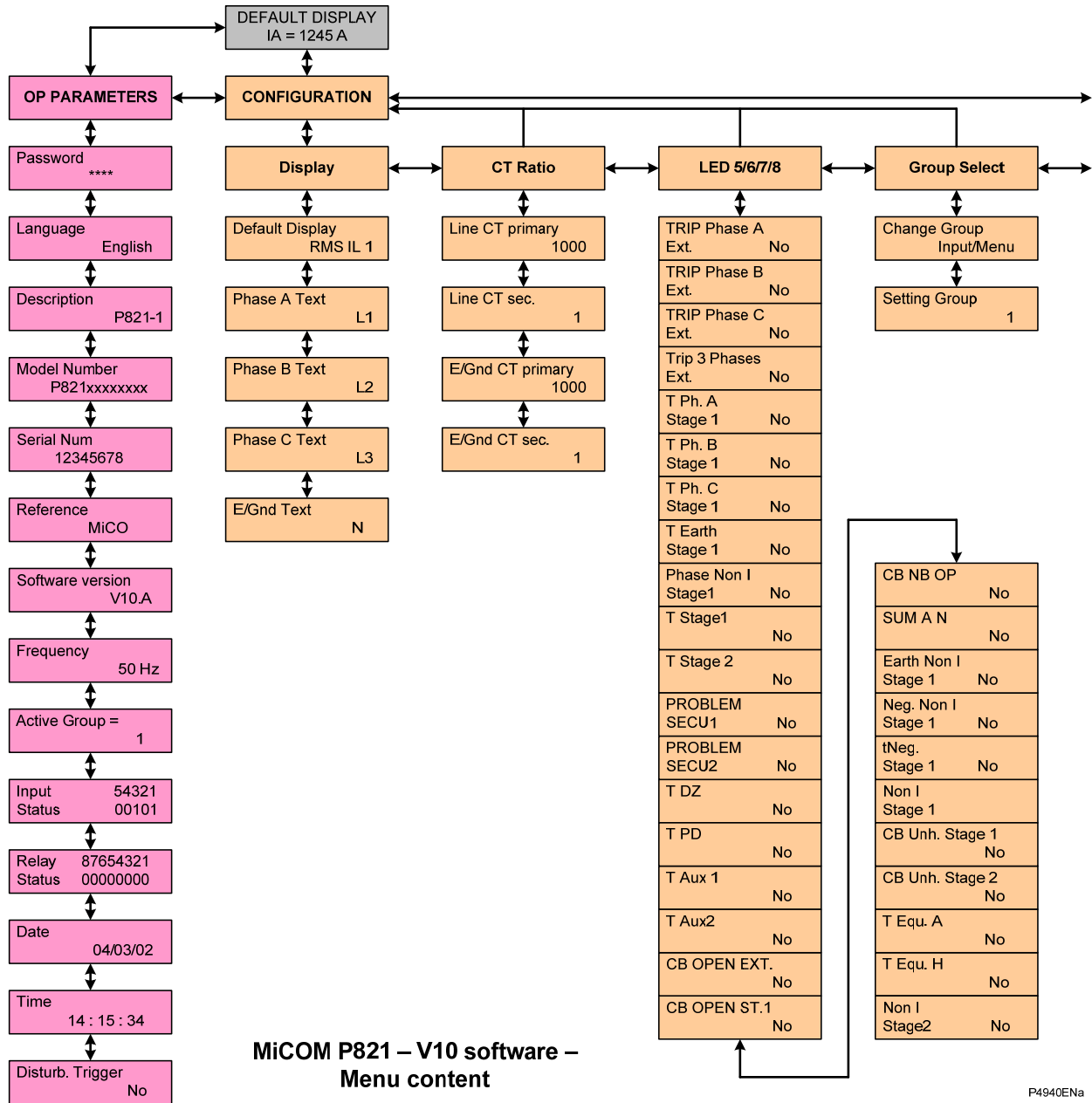

P4940ENa

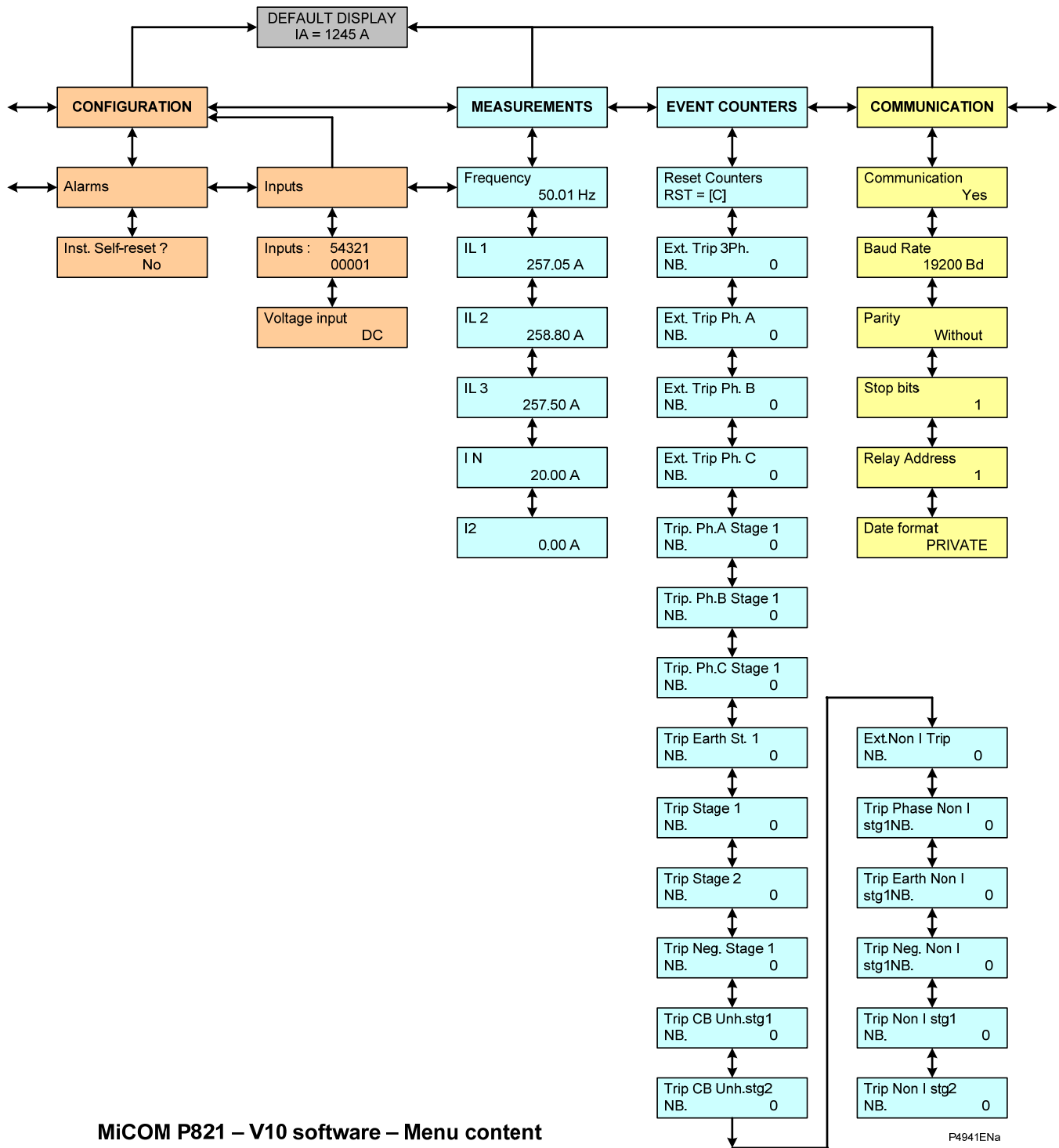

MiCOM P821 – V10 software – Menu content

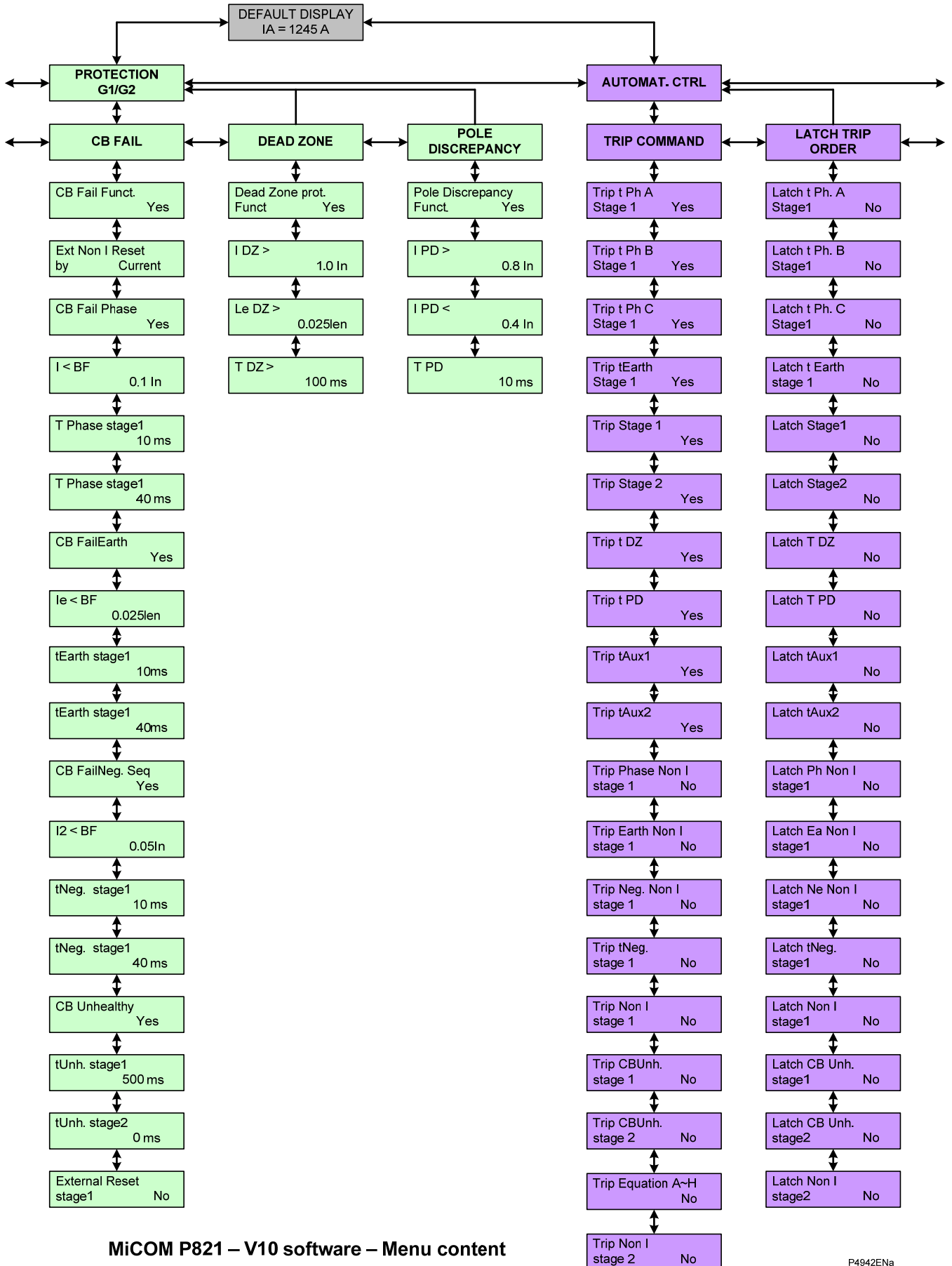

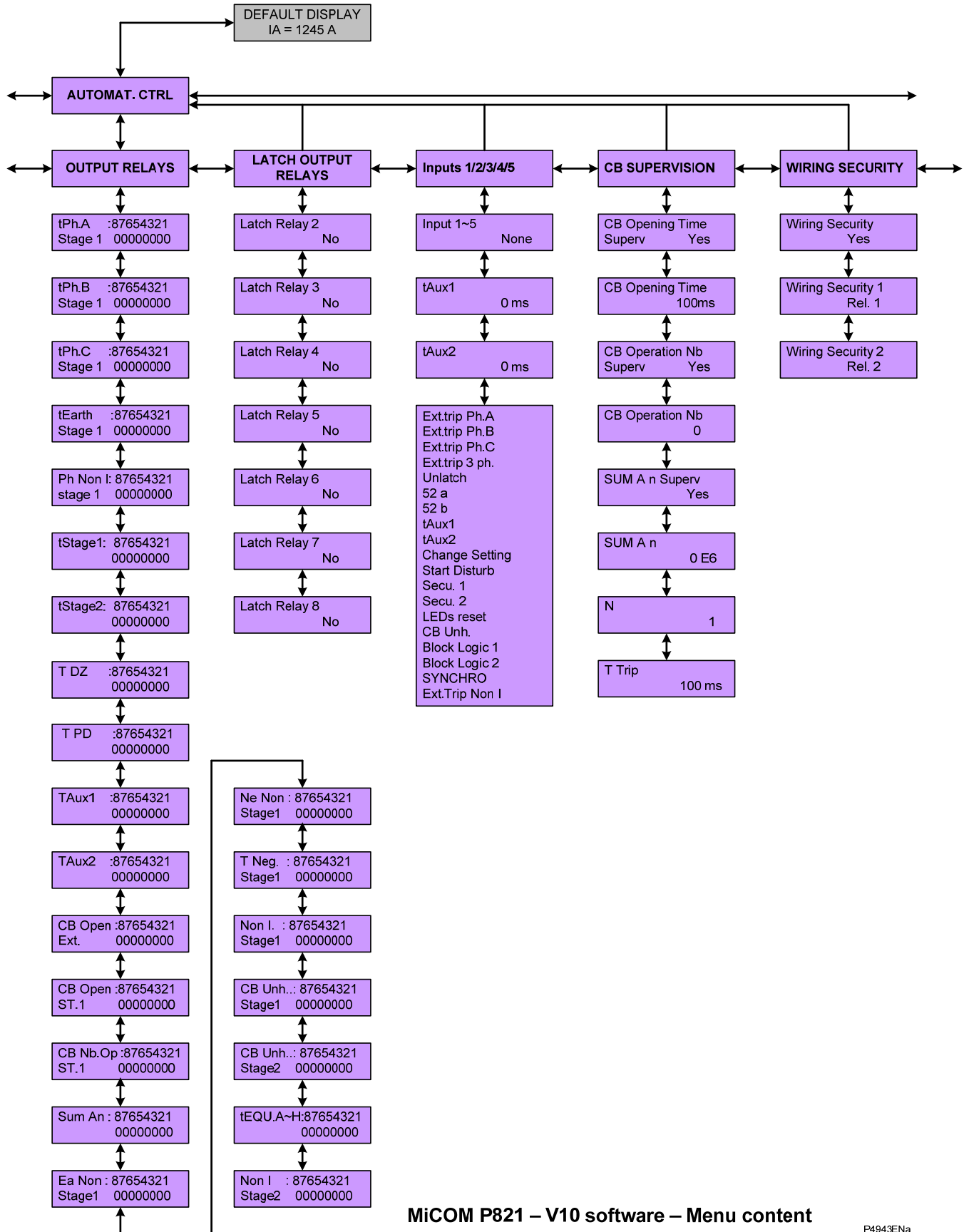

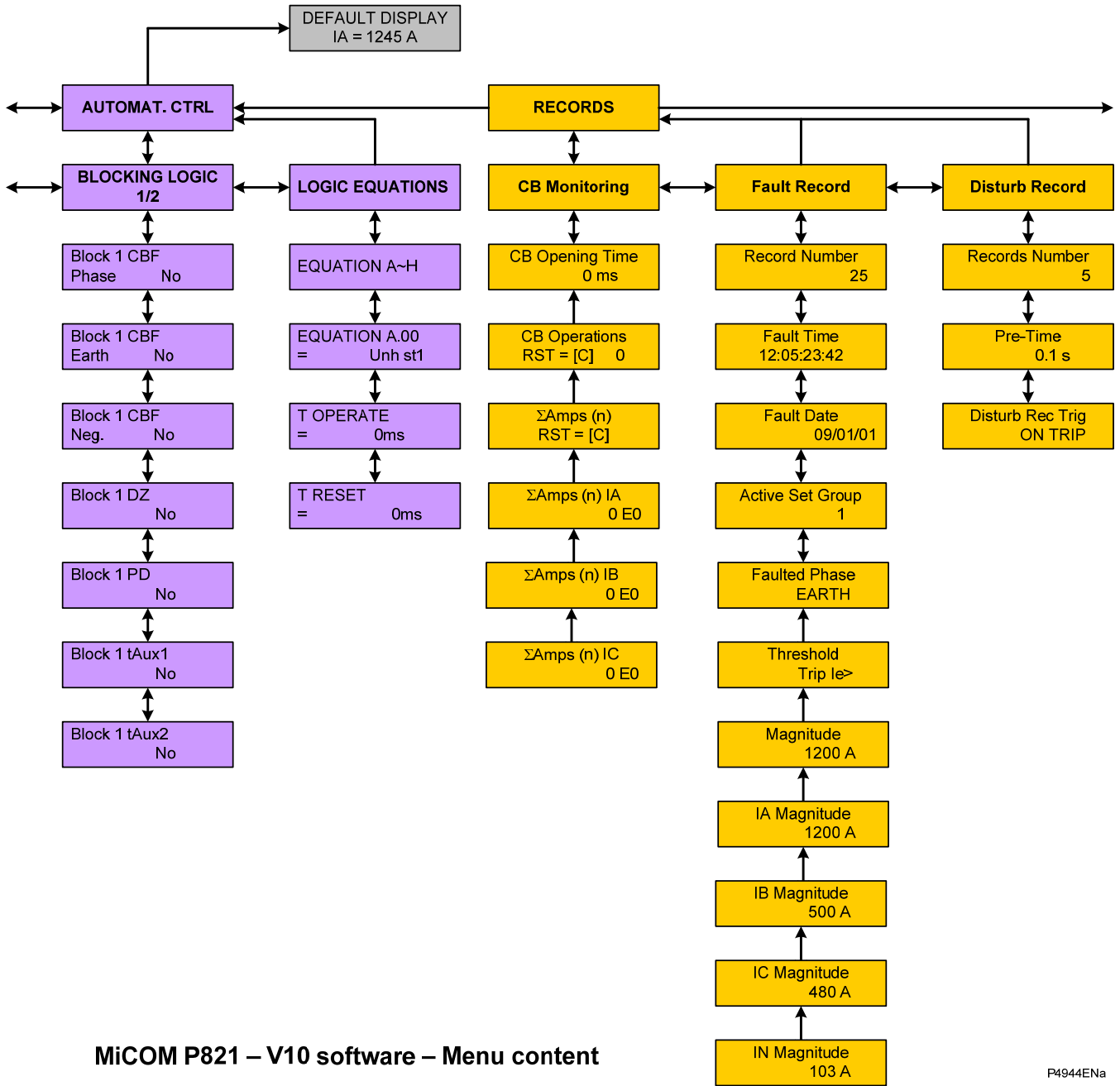

MiCOM P821 – V10 software – Menu content

P4944ENa

Notes:

APPLICATION GUIDE

CHAPTER 5

Date (month/year)	02/2016
Software Version	10.E
Hardware Suffix	Phase 2
Serial Number	Hardware installed

CONTENTS

Page (AP) 5-

1	Introduction	5
2	Circuit Breaker Failure (CBF) Protection	6
2.1	Basic Description	6
2.2	Phase Current Circuit Breaker Failure Detection Module	8
2.3	Ground Circuit Breaker Failure Detection Module	10
2.4	Negative Sequence Current Circuit Breaker Failure Detection Module	11
2.5	CB Unhealthy Logic	12
2.6	Typical Settings	13
2.6.1	Breaker Fail Timer Settings	13
2.6.2	Breaker Fail Undercurrent Settings	13
3	Dead Zone Protection	14
4	Pole Discrepancy	15
5	Auxiliary Timers	16
6	Wiring Security	17
6.1	Wiring Security	17
6.1.1	Function	17
6.1.2	Automation	17
7	Circuit Breaker State Monitoring	18
8	Circuit Breaker Condition Monitoring	19
8.1	Circuit Breaker Condition Monitoring Features	19
8.2	Tripping Time Supervision	19
8.2.1	Number of Breaker Operations	19
8.2.2	The Sum of the Broken Current Squared	20
8.2.3	Statistics	20
8.3	Setting Guidelines	21
8.3.1	Setting the ΣI^n Thresholds	21
8.3.2	Setting the Number of Operations Thresholds	21
8.3.3	Setting the Operating Time Thresholds	21
9	Blocking Logic Function	22
10	Logic Equations	23
11	Event Records	24
12	Fault Records	25
13	Disturbance Recorder	26
14	CT Requirements	27

FIGURES

	Page (AP) 5-
Figure 1 - CB Fail Timer	6
Figure 2 - Analogue under-current detection	7
Figure 3 - Phase element logic	9
Figure 4 - Ground current element logic	10
Figure 5 - Negative sequence current element logic	11
Figure 6 - CB unhealthy logic (show phase A only)	12
Figure 7 - Dead zone protection logic	14
Figure 8 - Pole discrepancy protection logic	15
Figure 9 - Wiring security	17
Figure 10 - Example of logic equation	23

1 INTRODUCTION

The P821 relay has been designed to provide more functionality in terms of protection, measuring, automatic operation and order control in any voltage electric network level.

This relay can be used in industrial and distribution network applications, as well as in high voltage and extremely high voltage protection applications. The specific nature of this relay makes it possible to respond to the various cases of application: busbar, energy intake, medium voltage subscriber, cable outlet, overhead line, etc... The earth and phase protection functions comprise instantaneous information and time delay information. This wide choice of characteristics of triggering times makes it possible to easily adapt this relay to an existing protection scheme, irrespective of the other relays already installed on the network.

The main functions integrated are listed below:

Functions	ANSI Code	MiCOM P821
CB FAIL	50BF (Ph), I<	X
CB FAIL Earth	50BF (N), IN<	X
CB FAIL Negative Sequence Current	50BF, I2<	X
Stage 1 Timer	tBF1	X
Stage 2 Timer	tBF2	X
Dead Zone (End Zone)	DBI	X
Pole discrepancy	Poles Not Together	X
Circuit Breaker monitoring, control and Statistics		X
Auxiliary timers	tAUX	2
Latching output contacts	86, Lockout	X
Setting groups		2
Measurements (True RMS)	Metering	4
Event records	SOE	250
Fault records		25
Disturbance records	Oscillography	15 sec
RS 232 front communication	Comms	X
RS 485 rear communication	Comms	X

Table 1 – Functions integrated in the P821 relay

2 CIRCUIT BREAKER FAILURE (CBF) PROTECTION

2.1 Basic Description

The Circuit Breaker Failure (CBF) function checks that the circuit breaker opens correctly when a tripping order is given.

For transmission or sub-transmission systems, slow fault clearance can also threaten system stability. It is therefore common practice to install circuit breaker failure protection, which monitors that the circuit breaker has opened within a reasonable time. If the fault current has not been interrupted after a set time delay from the start of the circuit breaker trip, the circuit breaker failure protection operates.

CBF operation can be used to backtrip upstream circuit breakers to ensure that the fault is isolated correctly.

CBF operation can also reset all start output contacts, ensuring that any blocking asserted on upstream protection is removed.

To fulfil this function, the user has 8 timers (4 x tBF1 and 4 x tBF2) which, when they expire, give an emergency tripping order (single-phase or three-phase).

In general, the tBF1 Output is connected to the emergency coils of the local circuit breaker "Retrip" and the tBF2 Output is connected to Busbar "Backtrip".

The timers tBF1 and tBF2 are in parallel. The timers tBF1 and [tBF2- tBF1] are in series. Therefore if the retrip did not function, a backtrip opens the Busbar.

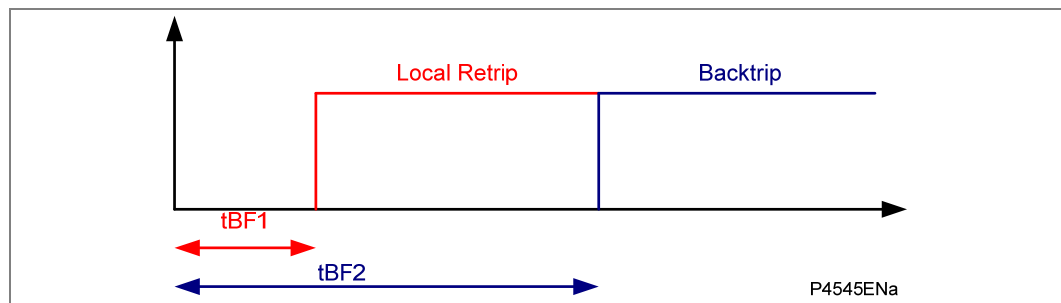

Figure 1 - CB Fail Timer

The circuit breaker failure function is initiated on the external tripping order.

The circuit breaker failure is reset (stop the timers) when:

- Analogue current is lower than the detection threshold
- External tripping orders reset to 0 if RESET is set to "YES".

Also the status of the CB can be a criterion for the CBF timer reset, when the CBF is initiated by a non-current protection trip.

The drop-off analogue detection (reset timer) is within 0.75 cycles:

- 15 ms at 50 Hz or 12.5 ms at 60 Hz

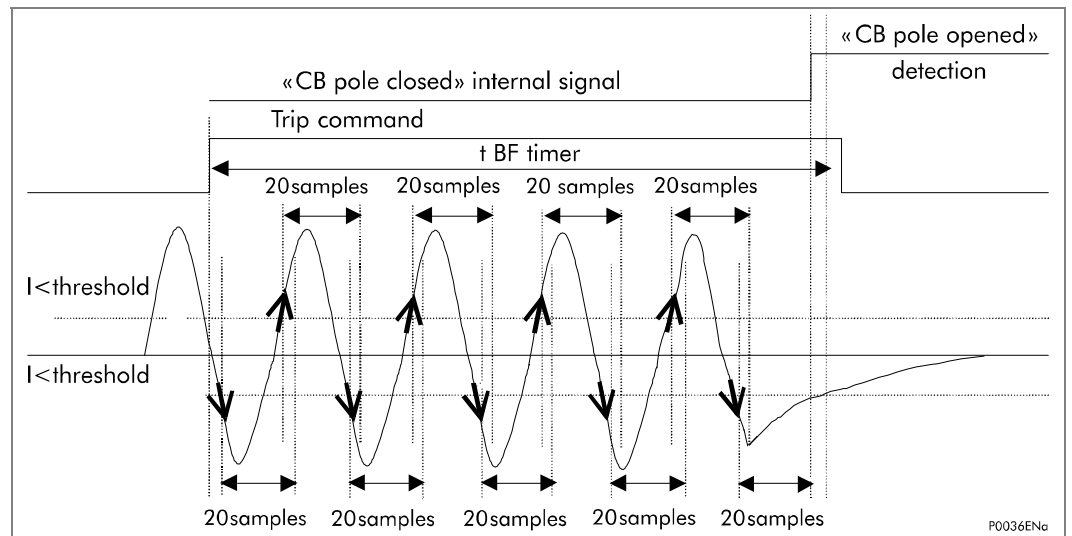

Figure 2 - Analogue under-current detection

This analogue detection is immune to a DC component and to CT saturation.

At each period, the pole opening detection algorithm detects when the set under-current threshold is crossed. If the threshold is exceeded, the detection delay starts again; if not, it does not do anything. When this delay has expired, the algorithm concludes the pole opening.

The current in this case is only filtered with a low-pass filter.

The CBF in the relay works on three types of criteria: phase current, earth current and negative sequence current. Each criterion has its own time delay setting and output signal.

The CBF function also has logic for an external CB unhealthy condition, to accelerate tripping of upstream circuit breakers.

2.2 Phase Current Circuit Breaker Failure Detection Module

For each of the three phases there is a single-phase current detection module. See Figure 3.

The current disappearance is detected directly from the samples in less than 0.75 periods. Each time the threshold is crossed by one or more samples within a 0.75 period, the time delay is restarted. If during this delay no crossing is detected, the time delay is reset to 0.

When the **External reset** setting is enabled, all CBF time delays reset once the CBF initiation is withdrawn.

Two types of external initiations can be used to initiate the CBF logic:

External single phase or three phase trip order:

- External trip order A
- External trip order B
- External trip order C
- External 3 phase trip order
- External Non-Current initiation
- External non I trip order

The “External non I trip order” can come from mechanical protection or a transformer buchholz relay that do not operate based on current detection. To provide retrip and back-trip in this case, the CBF criterion of the CB status should be considered.

In case 1, Ext trip order (A AND B) or (B AND C) or (A AND C) are treated as a three phase trip order.

In case 2, three reset options are provided:

- **Current only.** CBF logic operates based on the undercurrent detection only.
- **CB open only.** CBF logic operates based on the CB status only.
- **Current and CB open.** CBF logic operates based on both undercurrent detection and CB status. CBF resets only when the current is below the threshold and the CB status is open.

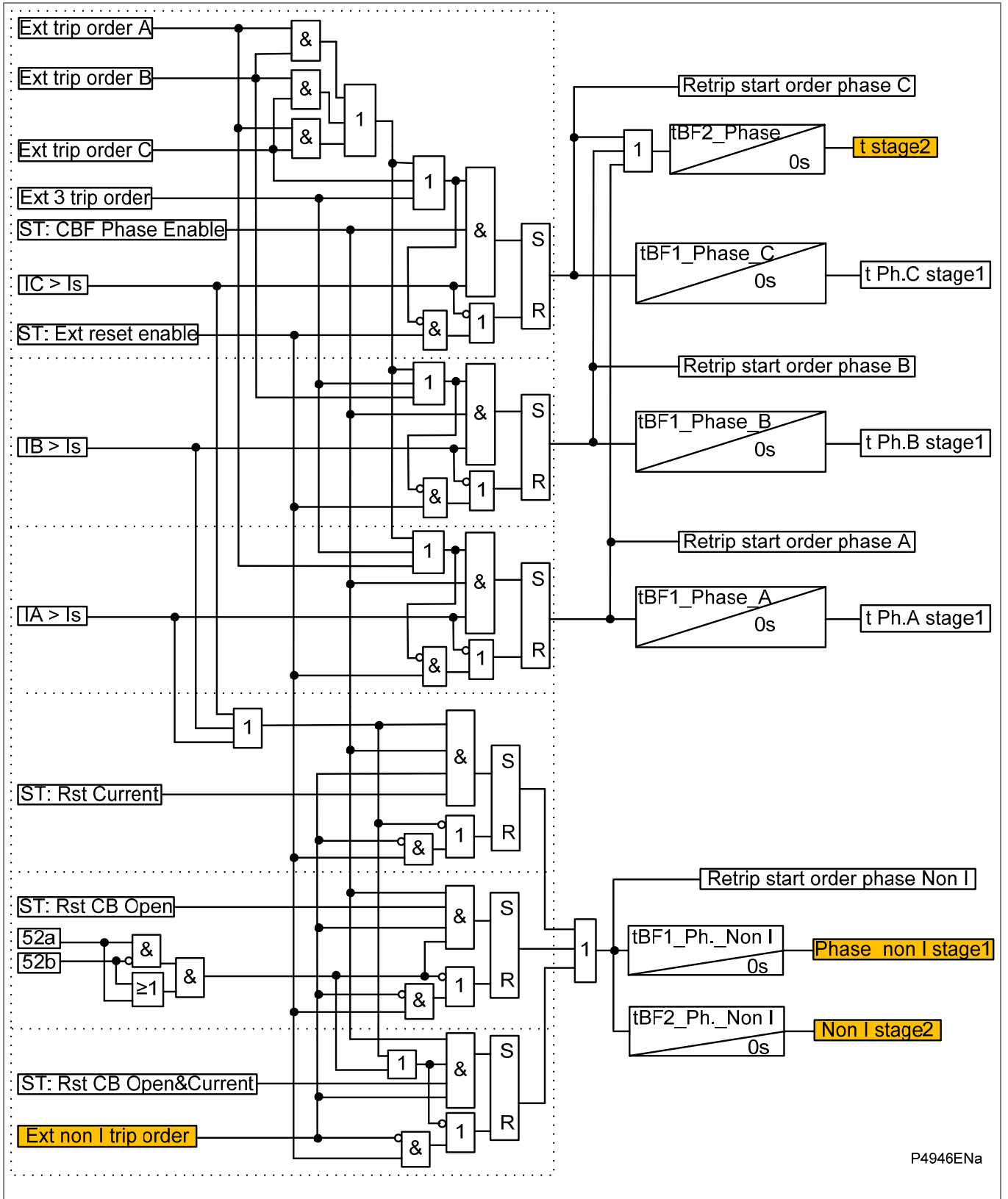

Figure 3 - Phase element logic

2.3 Ground Circuit Breaker Failure Detection Module

Figure 4 shows an overview of Ground CB Fail detection. Two external initiation logic circuits are used as a phase element.

In the same way as the phase element, the current disappearance is detected directly from the samples in less than 0.75 periods.

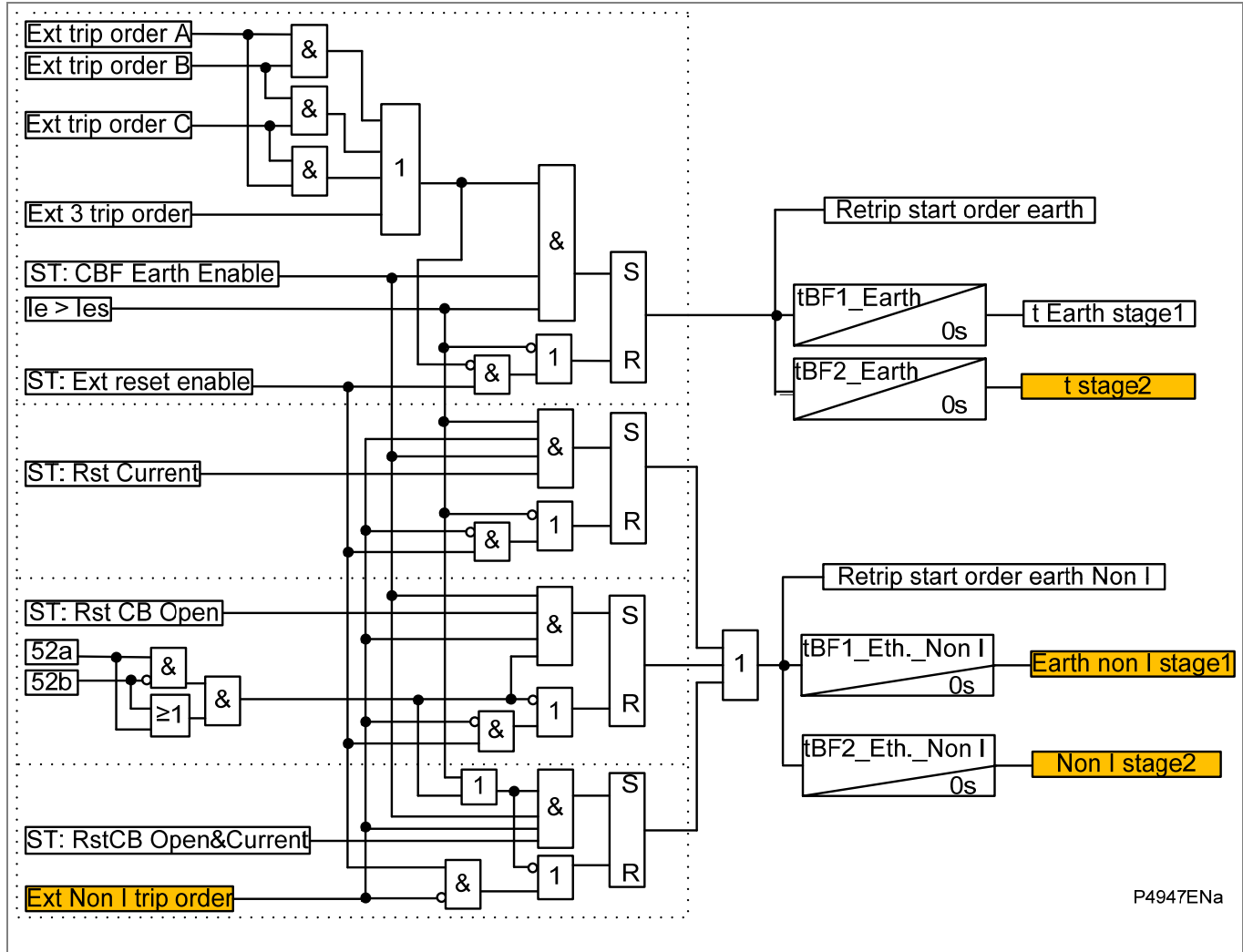

Figure 4 - Ground current element logic

2.4 Negative Sequence Current Circuit Breaker Failure Detection Module

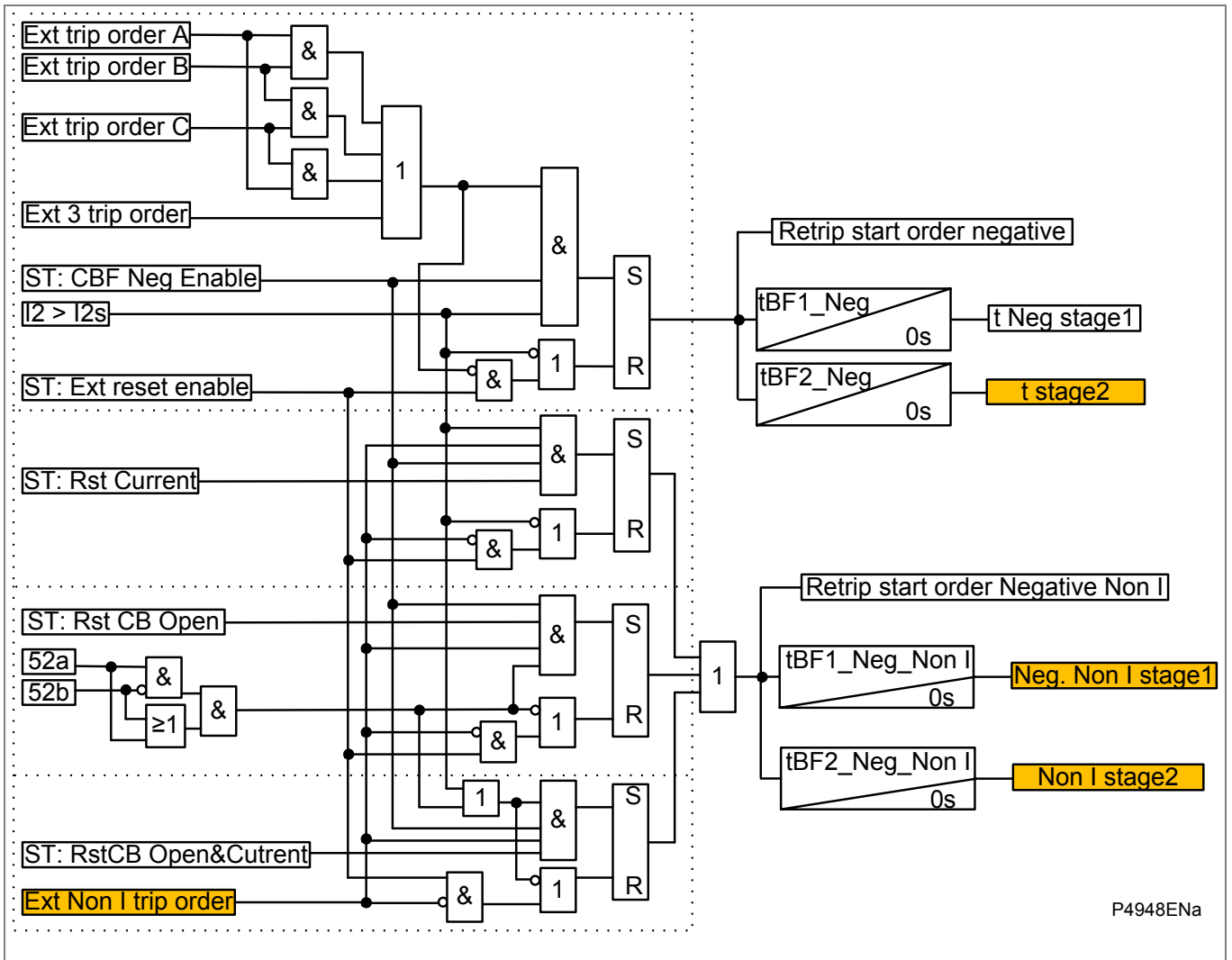

Figure 5 - Negative sequence current element logic

Two external initiation logic circuits are used as phase elements.

Unlike the phase element and ground element, the I_2 element works not on the samples but on the current extracted by Fourier Transforms, as the negative sequence current protection of P12x relays.

2.5 CB Unhealthy Logic

The **CB Unhealthy** function is designed for the condition that the CB operating mechanism has already been in a faulty status when it receives a trip command from another protection relay. The CBF function should then bypass the retrip progress and issue a back-trip command directly. The status of the CB operating mechanism is normally indicated by signals such as **Pressure low** or **Vacuum fail**, which can be categorized as **CB Unhealthy**.

To reduce the risk of logic input confusion during CB operating, the CB Unhealthy logic input should be kept energized for longer than 15 s before the retrip start order is issued to trigger the CB Unhealthy logic.

In the relay, when the logic input is mapped to CB Unhealthy and energized, and a retrip start order is issued, the expiration of delay timer tBF1_Unh and tBF2_Unh initiates a retrip and back-trip order.

Unlike the former tBF1 and tBF2, it is not necessary for the tBF2_CB_Unh to be greater than tBF1_CB_Unh. Figure 6 shows the logic diagram.

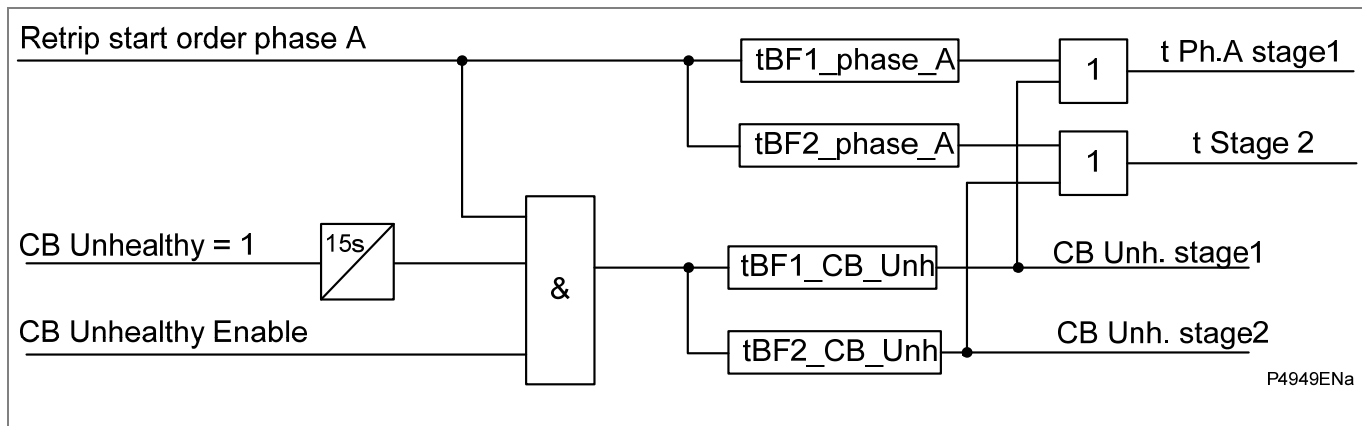

Figure 6 - CB unhealthy logic (show phase A only)

The following retrip start orders will initiate the CB Unhealthy timers as above.

- Retrip start order, phase A
- Retrip start order, phase B
- Retrip start order, phase C
- Retrip start order, earth current
- Retrip start order, negative
- Retrip start order, by non-current initiation and phase current criterion
- Retrip start order, by non-current initiation and earth current criterion
- Retrip start order, by non-current initiation and negative current criterion

2.6 Typical Settings

2.6.1 Breaker Fail Timer Settings

Typical timer settings to use are as follows:

CB Fail Reset Mechanism	tBF Time Delay	Typical Delay For 2 Cycle Circuit Breaker
External initiating element reset	CB interrupting time + Element reset time (max.) + error in tBF timer + safety margin	$50 + 50 + 10 + 50 = 160$ ms
CB open	CB auxiliary contacts opening/ closing time (max.) + error in tBF timer + safety margin	$50 + 10 + 50 = 110$ ms
Undercurrent elements	CB interrupting time + undercurrent element (max.) + safety margin operating time	$50 + 20 + 50 = 120$ ms

Table 2 - Typical timer settings

The examples above consider direct tripping of a 2-cycle circuit breaker.

<i>Note</i>	<i>Where auxiliary tripping relays are used, an additional 10-15ms must be added to allow for trip relay operation.</i>
-------------	-------------------------------------------------------------------------------------------------------------------------

2.6.2 Breaker Fail Undercurrent Settings

The phase undercurrent settings must be set less than the load current, to ensure that the undercurrent operation indicates that the circuit breaker pole is open. A typical setting for overhead line or cable circuits is $20\%I_n$, with $5\%I_n$ common for generator circuit breaker CBF.

The earth fault undercurrent elements must be set less than the respective trip setting in earth fault protection, typically half of this settings.

The negative sequence undercurrent element should be set higher than the maximum load unbalanced current, typically 150% higher. It should also be set lower than the respective negative sequence overcurrent trip setting if used, typically half of this setting.

3 DEAD ZONE PROTECTION

This function protects the section between the CT and the circuit breaker. Alternatively it protects the section between the CT and the isolator if the circuit breaker or the isolator is open.

The P821 uses the ANSI code 52a or 52b from the logic inputs, which corresponds to the auxiliary contacts of three poles. The module of the three phases detects the presence of current on at least a phase or earth current by comparing it with the configured threshold.

Unlike circuit breaker failure protection, Dead Zone protection is done on the modules of current and not on the samples, in exactly the same way as the P12x series DT overcurrent. Therefore the threshold has a hysteresis at 95% of the programmed threshold.

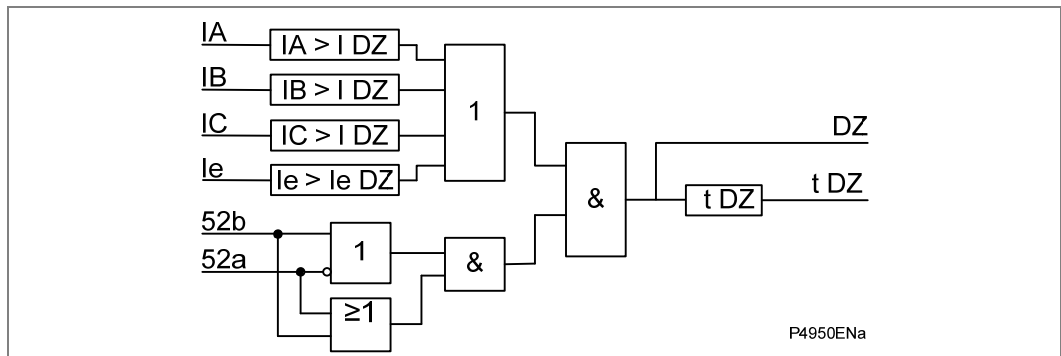

Figure 7 - Dead zone protection logic

4 POLE DISCREPANCY

This protection function supervises the pole discrepancy using the value of the phase currents.

Unlike the circuit breaker failure protection function, the pole discrepancy function works on the current modules and not on the samples, in exactly the same way as an overcurrent threshold for the P12x for [I PD >] and an undercurrent threshold for [I PD <]. Therefore, the threshold [I PD >] has a hysteresis at 95% of the programmed threshold and threshold [I PD <] has a Hysteresis at 105% of the programmed threshold.

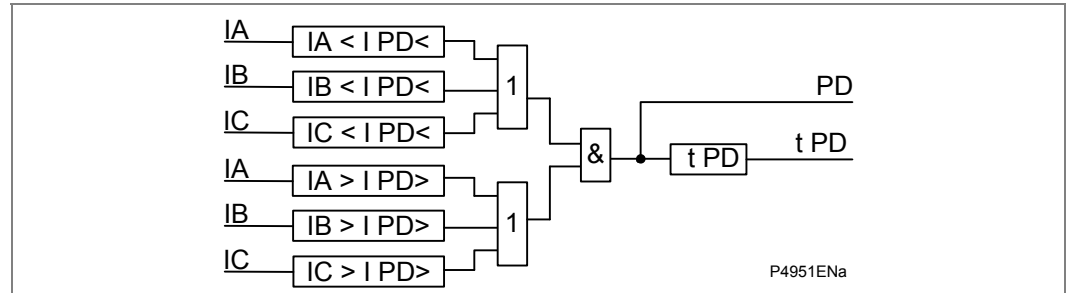

Figure 8 - Pole discrepancy protection logic

5 AUXILIARY TIMERS

Two auxiliary timers tAux1 and tAux2 are available associated to Aux1 and Aux2 logic inputs (refer to the **AUTOMAT. CTRL/INPUTS** menu). When these inputs are energised, the associated timers start. After the set time the output relays which are associated to the timer close (refer to the **AUTOMAT. CTRL/OUTPUTS** menu). The time delays are independently settable from 0 ms to 200 s.

6 WIRING SECURITY

6.1 Wiring Security

This security function is recommended but is not compulsory.

6.1.1 Function

This function protects the trip circuit against the short-circuiting of an output relay. If a de-energised relay is short-circuited, this function prevents a spurious trip. This protection function uses the redundancy of the tripping order.

Example of a trip circuit secured:

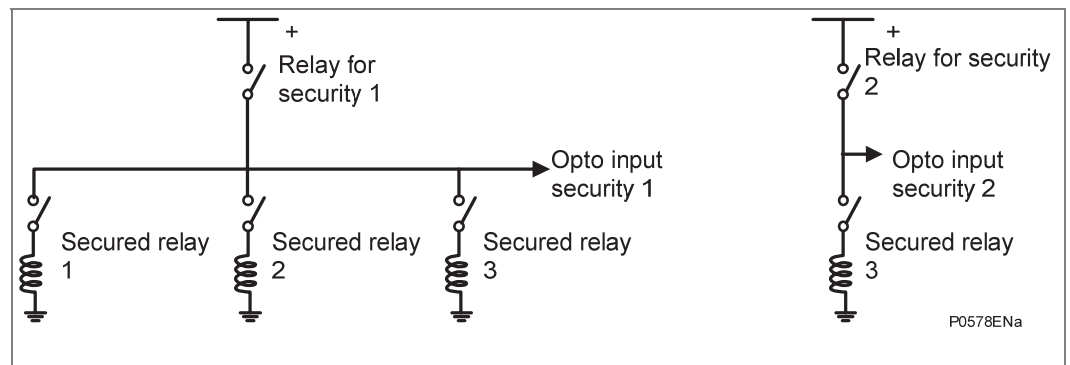

Figure 9 - Wiring security

The relay command for security 1 must be a logical OR of the orders of the secured relays 1, 2 and 3. The relay command for security 2 must be the same as for the secured relay 4.

The short-circuit of the relay for security 1 or 2 is detected by the wiring scheme using the relay status acquisitions with opto inputs called security 1 and security 2.

6.1.2 Automation

If the relay security 1 or the relay security 2 are polarised and the associated order is not sent, the protection is definitely put out of service. The relays are then not commanded and the watchdog is set to 0.

Note To set back the protection in service, the auxiliary power must be disconnected.

The relay order is delayed by 40 ms at drop off (very fast internal logic), to allow the opto input to detect the opening of the relay after a breaker failure.

Note This security function checks that the relay is not closed when there is no trip order. However, it does not check that the relay is correctly ordered when a trip command has been sent.

7 CIRCUIT BREAKER STATE MONITORING

An operator at a remote location requires a reliable indication of the state of the switchgear. Without an indication that each circuit breaker is either open or closed, the operator has insufficient information to decide on switching operations. The MiCOM P821 relays incorporate circuit breaker state monitoring, giving an indication of the position of the circuit breaker. This can either be displayed on the front panel LCD or through the communications network.

The positions of the CB are selectable in the ***AUTOMAT.CTRL/Inputs*** and ***CONFIGURATION/LED*** menu.

The MiCOM P821 can inform the operator that the CB is not open following a remote trip command (see section 2).

8 CIRCUIT BREAKER CONDITION MONITORING

Periodic maintenance of circuit breakers is necessary to ensure that the trip circuit and mechanism operate correctly, and also that the interrupting capability has not been compromised due to previous fault interruptions. Generally, such maintenance is based on a fixed time interval, or a fixed number of fault current interruptions. These methods of monitoring circuit breaker condition give a rough guide only and can lead to excessive maintenance.

The relays record various statistics related to each circuit breaker trip operation, allowing a more accurate assessment of the circuit breaker condition to be determined. These monitoring features are discussed in the following section.

8.1 Circuit Breaker Condition Monitoring Features

For each circuit breaker trip operation the relay records statistics as shown in the following table taken from the relay menu. The **RECORDS/CB Monitoring** menu cells shown are counter values only. These counters may be reset to zero, for example, following a maintenance inspection and overhaul.

8.2 Tripping Time Supervision

The Breaker tripping time is set and monitored ; this time is measured according to the opening time:

- If the Breaker opens (52a goes from 1 to 0, or 52b goes from 0 to 1) after the external trip rising edge and before the completion of tBF1, the opening time is the duration between the rising edge and the 52a or 52b change.
- If the Breaker opens after tBF1, the opening time is the duration between the external trip order and the 52a change.
- If the Breaker opens on an order other than CBF (Dead Zone protection, Pole Discrepancy, tAux1, tAux2), there is no supervision because only the 1st stage CBF function would trip the local Breaker.

The measured time is compared with the time set in the Supervision menu. If the breaker opens after tBF1 and the supervised set time is less than tBF1, the message **Opening time on external order** is displayed. If the breaker does not open after tBF1 and the supervised set time, the message **Opening time overshoot on 1st stage order** is displayed.

8.2.1 Number of Breaker Operations

The number of breaker operations is set and supervised. This number is incremented at each opening time (52a goes from 1 to 0, or 52b goes from 0 to 1) and is compared with the set value.

If the number of operations exceeds the set value, the logical information number of operations exceeded (NB_OPE) is flagged.

The alarm can be cleared without resetting the counter. A new alarm is then generated at the next breaker opening.

8.2.2 The Sum of the Broken Current Squared

The sum of the broken current squared for each breaker operation is set and supervised. This number is added at each opening time (52a goes from 1 to 0, or 52b goes from 0 to 1) and is compared with the set value.

If the number of broken current squared exceeds the set value, the broken current squared exceeded signal (Sum A 2N) is be flagged

8.2.3 Statistics

The statistics function records the following events in the **EVENT COUNTERS** menu and are resettable:

- Number of three phase external trips
- Number of phase A external trips
- Number of phase B external trips
- Number of phase C external trips
- Number of phase A retrips
- Number of phase B retrips
- Number of phase C retrips
- Number of neutral retrips
- Number of 1st stage order
- Number of 2nd stage order
- Number of negative retrips
- Number of CB Unhealthy retrips
- Number of CB Unhealthy back-trips
- Number of external Non-current initiated trips
- Number of Non-current initiated CBF retrip by phase current criterion
- Number of Non-current initiated CBF retrip by earth current criterion
- Number of Non-current initiated CBF retrip by negative sequence current criterion
- Number of Non-current initiated CBF retrips
- Number of Non-current initiated CBF back-trips

8.3 Setting Guidelines

8.3.1 Setting the ΣI^n Thresholds

Where overhead lines are prone to frequent faults and are protected by Oil Circuit Breakers (OCBs), oil changes account for a large proportion of the life cycle cost of the switchgear. Generally, oil changes are performed at a fixed interval of circuit breaker fault operations. However, this may result in premature maintenance where fault currents tend to be low, so oil degradation is slower than expected.

The ΣI^n counter monitors the cumulative severity of the duty placed on the interrupter, allowing a more accurate assessment of the circuit breaker condition to be made.

For OCBs, the dielectric withstand of the oil generally decreases as a function of ΣI^2t . This is where 'I' is the fault current broken, and 't' is the arcing time within the interrupter tank (not the interrupting time). As the arcing time cannot be determined accurately, the relay would normally be set to monitor the sum of the broken current squared, by setting $n = 2$.

For other types of circuit breaker, especially those operating on higher voltage systems, practical evidence suggests that the value of $n = 2$ may be inappropriate. In such applications n may be set to 1.

An alarm in this instance may be indicative of the need for gas/vacuum interrupter HV pressure testing, for example.

It is imperative that any maintenance programme must be fully compliant with the switchgear manufacturer's instructions.

8.3.2 Setting the Number of Operations Thresholds

Every operation of a circuit breaker results in some degree of wear for its components. Thus, routine maintenance, such as oiling of mechanisms, may be based on the number of operations. Suitable setting of the maintenance threshold will allow an alarm to be raised, indicating when preventative maintenance is due.

If maintenance is not carried out, the relay can be set to lockout the autoreclose function when it reaches an operations threshold. This prevents further reclosure when the circuit breaker has not been maintained to the standard demanded by the switchgear manufacturer's maintenance instructions.

Certain circuit breakers, such as Oil Circuit Breakers (OCBs) can only perform a certain number of fault interruptions before requiring maintenance attention. This is because each fault interruption causes carbonising of the oil, degrading its dielectric properties.

8.3.3 Setting the Operating Time Thresholds

Slow CB operation is also indicative of the need for mechanism maintenance. Therefore an alarm is provided which is settable from 100 ms to 5 s. This time is set in relation to the specified interrupting time of the circuit breaker.

9 BLOCKING LOGIC FUNCTION

Two blocking logic circuits can be assigned to opto inputs in the **AUTOMAT.CTL\BLOCKING LOGIC1/2** menu. When the relevant opto inputs are energized, the following protection functions can be blocked.

- CBF phase element
- CBF earth element
- CBF negative element
- Dead Zone protection
- Pole Discrepancy protection
- tAux1
- tAux2

10 LOGIC EQUATIONS

The logic equations can be used to construct complex Boolean logic using the following operators: OR, OR NOT, AND, AND NOT.

An example logic implementation using Equation A is shown below:

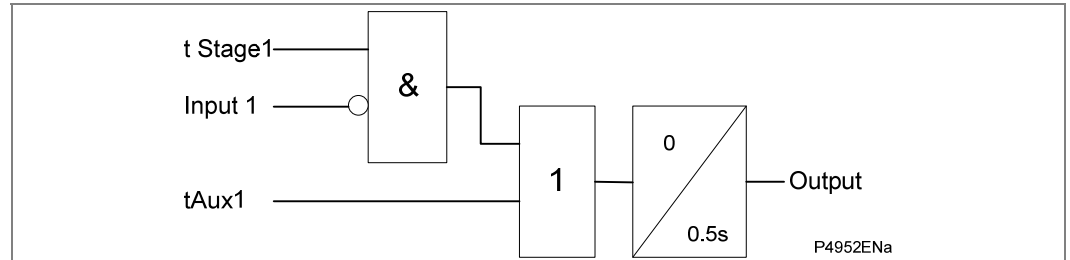

Figure 10 - Example of logic equation

There are 8 equations of 16 operands chosen within all instantaneous and temporised events (thresholds and protections flags, tAux ...) and all inputs.

Every equation has a pick up time delay settable from 0 s to 600 s with a step of 0.01 s.

Every equation has a drop off time delay settable from 0 s to 600 s with a step of 0.01 s.

11 **EVENT RECORDS**

The relay records and time tags up to 250 events and stores them in non-volatile flash memory. This enables the system operator to establish the sequence of events that occurred within the relay following a particular power system condition, switching sequence etc. When the available space is exhausted, the oldest event is automatically overwritten by the new one.

The relay's real time clock provides the time tag to each event, to a resolution of 1 ms.

The event records can be viewed either using the RS232 port on the front panel or remotely using the rear RS485 port.

To extract records from a remote source using the rear RS485 port, refer to the Mapping Database of the Technical Guide, where the procedure is fully explained.

12 FAULT RECORDS

Each time any of the programmed thresholds are crossed, a fault record is created and stored in memory. The fault record tags up to 25 faults and stores them in non-volatile flash memory. This enables the system operator to understand and analyse the network failures. When the available space is exhausted, the oldest fault is automatically overwritten by the new one.

To view the actual fault record, use the **RECORD/Fault Record** menu, which is selectable from up to 25 records. These records consist of fault flags, fault measurements etc. The time stamp given in the fault record is more accurate than the corresponding stamp given in the event record as the event is logged some time after the actual fault record is generated.

The fault records can be viewed either on the display, with a PC connected to the front panel RS232 port or remotely using the rear RS485 port.

To extract records from a remote source using the rear RS485 port, refer to the Mapping Database of the Technical Guide, where the procedure is fully explained.

13 DISTURBANCE RECORDER

The product can store a settable number and length of disturbance records in non-volatile flash memory. Power-on diagnostics check the integrity of the records.

The disturbance recorder time has five options:

- 5 records of 3 seconds (by default)
- 4 records of 3 seconds
- 3 records of 5 seconds
- 2 records of 7 seconds
- 1 record of 9 seconds

Disturbance records continue to be recorded until the available memory is exhausted, at which time the oldest record is overwritten to make space for the newest one.

The recorder stores actual samples which are taken at a rate of 32 samples per cycle in COMTRADE format.

Each disturbance record consists of analogue data channels and digital data channels. (Note that the relevant CT ratios for the analogue channels are also extracted to enable scaling to primary quantities).

The recording of disturbance data can be triggered by a change of state in the menu **OP PARAMETERS/Disturb. Trigger**, the protection functions or thresholds, the operation of a logic input or by a remote command.

The **RECORD/DISTURB. RECORDS** menu is shown below :

MENU TEXT	SETTING RANGE		STEP SIZE
	MIN	MAX	
Disturb Record			
Records number	1	5	1
Pre-Time	0.1 s	8.9 s	0.1 s
Disturb Rec Trig	On Inst.	On Trip	

Table 3 - Record/Disturb. Records menu

Disturbance data can be extracted through the front RS232 communications port using a PC or through the rear RS485 port using the Modbus protocol.

14 CT REQUIREMENTS

The CT requirements for the MiCOM P821 Breaker fail relay are given below.

The current transformer requirements are based on a maximum prospective fault current of 50 times the relay rated current (I_n) and the relay having an instantaneous setting of 25 times rated current (I_n). The current transformer requirements are designed to provide operation of all protection elements.

Where the criteria for a specific application are in excess of those detailed above, or the actual lead resistance exceeds the limiting value quoted, the CT requirements may need to be increased according to the formulae in the following sections.

Nominal Rating	Nominal Output	Accuracy Class	Accuracy Limit Factor	Limiting lead resistance
1A	2.5VA	10P	20	1.3 ohms
5A	7.5VA	10P	20	0.11 ohms

Abbreviations used:

V_k = Required CT knee-point voltage (volts),

I_{fn} = Maximum prospective secondary earth fault current (amps),

I_{fp} = Maximum prospective secondary phase fault current (amps),

I_{cn} = Maximum prospective secondary earth fault current or 31 times $I>$ setting (whichever is lower) (amps),

I_{cp} = Maximum prospective secondary phase fault current or 31 times $I>$ setting (whichever is lower) (amps),

I_{sn} = Stage 2 & 3 Earth Fault setting (amps),

I_{sp} = Stage 2 and 3 setting (amps),

R_{CT} = Resistance of current transformer secondary winding (ohms)

R_L = Resistance of a single lead from relay to current transformer (ohms),

R_{rp} = Impedance of relay phase current input at $30I_n$ (ohms),

R_{rn} = Impedance of the relay neutral current input at $30I_n$ (ohms).

The CT requirement is:

$$V_k > I_{fp} \times (R_{CT} + 2R_L + R_{rp} + R_{rn})$$

Notes:

CONNECTION DIAGRAMS

CHAPTER 6

Date (month/year)	02/2016
Software Version	10.E
Hardware Suffix	Phase 2
Serial Number	Hardware installed

CONTENTS

Page (CO) 6-

1	MiCOM Relay Off Scheme	5
2	Communication Cable Connection	6
2.1	Products Plugged in the Same Panel	6
2.2	Communication between Distant Products	7

FIGURES

Page (CO) 6-

Figure 1 - Scheme representing MiCOM relay off	5
Figure 2 - Products plugged in the same panel	6
Figure 3 - Communication between Distant Products	7

Notes

2 COMMUNICATION CABLE CONNECTION

2.1 Products Plugged in the Same Panel

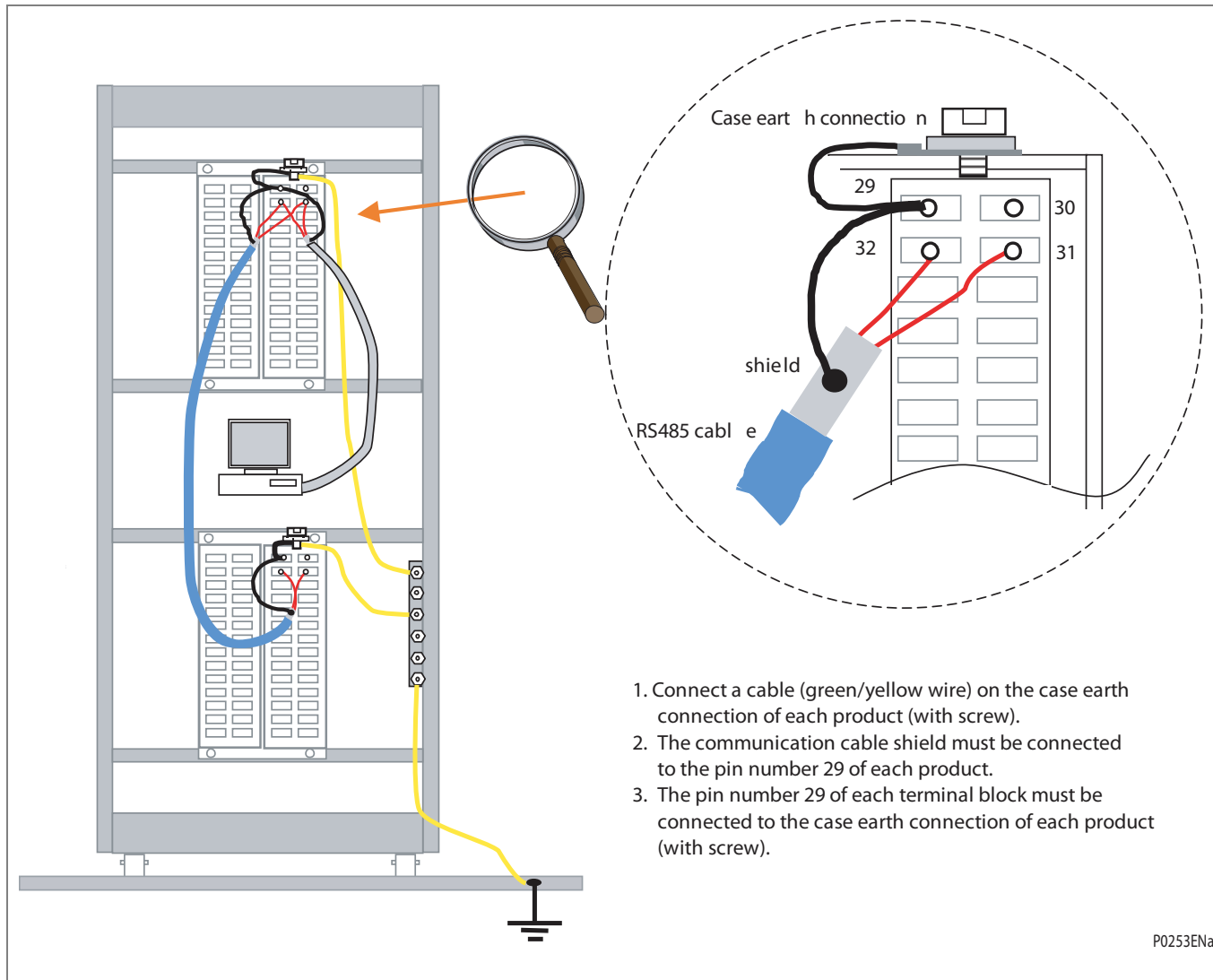

Figure 2 - Products plugged in the same panel

2.2 Communication between Distant Products

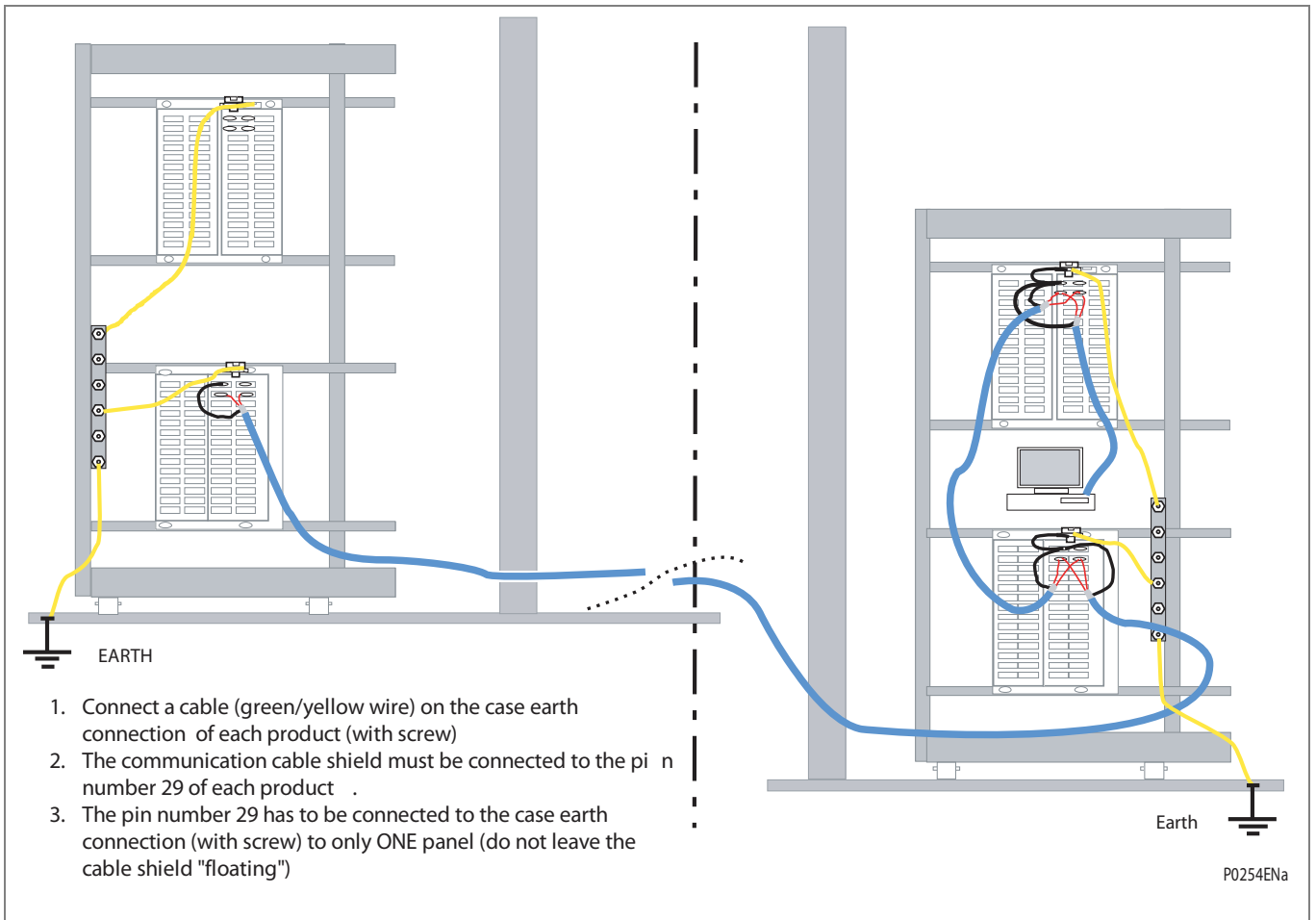

Figure 3 - Communication between Distant Products

Notes:

TECHNICAL DATA

CHAPTER 7

Date (month/year)	02/2016
Software Version	10.E
Hardware Suffix	Phase 2
Serial Number	Hardware installed

CONTENTS

Page (TD) 7-

1	Protection Functions	5
1.1	Circuit Breaker Failure (Phase and Earth (by Current Residual Detection))	5
1.2	Dead Zone Protection	5
1.3	Pole Discrepancy Protection	5
2	Automation Functions	6
2.1	Auxiliary Timers	6
2.2	Circuit Breaker Control and Monitoring	6
3	Recording Functions	7
3.1	Event Recorder	7
3.2	Fault Recorder	7
3.3	Disturbance Recorder	7
4	Communication	8
4.1	RS485 port Connectors	8
4.2	RS232 port	8
5	Inputs and Outputs	9
5.1	AC Inputs	9
5.2	Logic Inputs	9
5.3	Auxiliary Power Supply and Operating Range of Logic Inputs	9
5.4	Power Supply Variations	10
5.5	Logic Outputs	10
6	Accuracy	11
7	CT Data	12
8	High Voltage Withstand (Insulation)	13
9	Electrical Environment (EMC)	14
9.1	High frequency disturbance	14
9.2	Electrostatic discharge	14
9.3	Fast transient	14
9.4	Surge	14
9.5	Conducted Emissions	14
9.6	Radiated Emissions	14
9.7	Conducted Immunity	14
9.8	Radiated Immunity	15
9.9	Radiated immunity from digital telephones	15
9.10	ANSI Surge Withstand Capability	15
9.11	Magnetic Field Immunity	15

10	Environment	16
10.1	Temperature	16
10.2	Humidity	16
10.3	Enclosure protection	16
10.4	Sinusoidal Vibrations	16
10.5	Shocks	16
10.6	Shock withstand & Bump	16
10.7	Seismic	16
10.8	Corrosive Environments	16

11	EU Directive	17
11.1	EMC Compliance	17
11.2	Product Safety	17

1 PROTECTION FUNCTIONS

1.1 Circuit Breaker Failure (Phase and Earth (by Current Residual Detection))

Phase current threshold	$I <$	5% to 400% x rated current, step of 1%
Standard earth current	$I_{e <}$	5% to 400% x rated current, step of 1%
Sensitive earth current	$I_{e <}$	1% to 400% x rated current, step of 1%
Very sensitive earth current	$I_{e <}$	0,2% to 80% x rated current, step of 0,1%
Negative sequence current	$I_{2 <}$	5% to 200% x rated current, step of 1%
CB failure time 1	t_{BF1}	0 ms to 40 s; step of 5 ms
CB failure time 2	t_{BF2}	0 ms to 40 s; step of 5 ms

1.2 Dead Zone Protection

Phase current threshold		5% to 400% x rated current, step of 1%
Standard earth current	$I_{e >}$	5% to 400% x rated current, step of 1%
Sensitive earth current	$I_{e >}$	1% to 400% x rated current, step of 1%
Very sensitive earth current	$I_{e >}$	0,2% to 80% x rated current, step of 0,1%
Dead Zone time	t_{DZ}	0 ms to 40 s; step of 5 ms

1.3 Pole Discrepancy Protection

Current threshold		5% to 400% x rated current, step of 1%
Pole Discrepancy time	t_{PD}	0 ms to 40 s; step of 5 ms

2 AUTOMATION FUNCTIONS

2.1 Auxiliary Timers

Auxiliary timer numbers	2 independent associated to the logic Inputs Aux 1 and Aux 2
tAux1 and tAux2 Range	0 ms to 200 s ; step of 10 ms

2.2 Circuit Breaker Control and Monitoring

Circuit breaker opening time	(t Open Pulse)	50 ms to 1 s; step of 10 ms
Circuit breaker closing time	(t Close Pulse)	50 ms to 1 s; step of 10 ms
Circuit breaker opening alarm threshold	0 to 50000 operations	
Amps or square amps alarm threshold	0 to 4 10 ⁹ ; step of 10 ⁶	
Circuit breaker tripping time alarm threshold	100 ms to 5 s; step of 100 ms	
Circuit breaker closing time alarm threshold	100 ms to 5 s; step of 100 ms	

3 RECORDING FUNCTIONS

3.1 Event Recorder

Capacity	250 events
Time-tag	to 1 millisecond
Triggers	Any selected protection alarm and threshold
	Logic input change of state
	Self test events
	Setting changes

3.2 Fault Recorder

Capacity	25 faults
Time-tag	to 1 millisecond
Triggers	Any selected protection alarm and threshold
Data	Fault date
	Protection thresholds
	Setting Group
	AC inputs measurements(RMS)
	Fault magnitudes

3.3 Disturbance Recorder

Capacity	15s in total	
Sampling rate	32 samples per frequency cycle	
Settings	Pre-time	100 ms to 3 s, step of 100 ms
	Post-time	100 ms to 3 s, step of 100 ms
Triggers	Any selected protection alarm and threshold	
	Logic input	
	Remote command HMI	
Data	AC input channels	
	Digital input and output states	
	Frequency value	

4 COMMUNICATION

4.1 RS485 port Connectors

RS 485 port Connectors	rear port, screened twisted wire pair screws or snap-on
Protocols	MODBUS™ RTU Courier IEC 60870-5-103 DNP3
Data rate	300 to 38 400 baud (programmable)

4.2 RS232 port

RS 232 port	front port, screened twisted wire cable
Protocol	MODBUS™ RTU
Connector	Sub-D 9 pin female connector

5 INPUTS AND OUTPUTS

5.1 AC Inputs

Phase current inputs		1 and 5 Amps by connection
Earth current inputs		1 and 5 Amps by connection
Frequency	Range	45 to 65 Hz
	Nominal	50/60 Hz
Current inputs burden	Phase	< 0.025 VA (1 A)
		< 0.3 VA (5 A)
	Earth	< 0.008 VA at 0,1I _E (1 A)
Thermal withstand		< 0.01 VA for 0,1I _E (5 A)
		1s @ 100 x rated current
		2s @ 40 x rated current
		continuous @ 4 x rated current

5.2 Logic Inputs

Logic input type	independent optical isolated
Logic input burden	<10 mAmps per input
Logic input recognition time	< 5 ms

5.3 Auxiliary Power Supply and Operating Range of Logic Inputs

The logic inputs shall be powered with a DC voltage, excepted the A, F, T M auxiliary voltage range which accepts both DC and AC voltage as logic input control voltage.

Ordering Code (Cortec)	Auxiliary voltage range V _x	Logic input voltage range
A (ph1)	24 – 60 Vdc	24 – 60 Vdc
F (ph1)	48 - 150 Vdc	48 - 150 Vdc
H (ph1)	130 - 250 Vdc	105-145V dc
	110 – 250 Vac	
M (ph1)	130 - 250 Vdc	130 - 250 Vdc
	110 – 250 Vac	100 – 250 Vac
T (ph1)	48 - 150 Vdc	48 - 150 Vdc (special EA)
U (ph1)	130 - 250 Vdc	130 - 250 Vdc (special EA)
	110 – 250 Vac	
V (ph1)	48 - 150 Vdc	110 Vdc -30%/+20%
W (ph1)	130 - 250 Vdc	220 Vdc -30%/+20%
	110 – 250 Vac	
H (ph2)	48 - 250 Vdc	105-145 Vdc
	48 –240 Vac	
T (ph2)	48 - 250 Vdc	24 - 250 Vdc (ac immune)
	48 –240 Vac	
	Special EA (**)	

Ordering Code (Cortec)	Auxiliary voltage range Vx	Logic input voltage range
V (ph2)	48 - 250 Vdc 48 -240 Vac	110 Vdc -30%/+20%
W (ph2)	48 - 250 Vdc 48 -240 Vac	220 Vdc -30%/+20%
Z (ph2)	24 - 250 Vdc 24 - 240 Vac	24 - 250 Vdc 24 - 240 Vac

5.4 Power Supply Variations

Power supply variations	dc \pm 20 %
	ac - 20%, +10%
Ripple	12 %.
Power off withstand	50 ms
Burden	2 W standby + 0.25 W per energised relay
	5 VA standby + 0.4 VA per energised relay.

5.5 Logic Outputs

Logic output type	dry contact Ag Ni	
Logic output rating	Make	30 Amps and carry for 3 s
	Carry	5 Amps continuous
	Rated voltage	250Vac
	Break AC	1500 VA resistive
		1500 VA inductive ($\cos \phi = 0.5$)
		220 Vac, 5 Amps ($\cos \phi = 0.6$)
	Break DC	135 Vdc, 0.3 Amps (L/R = 30 ms)
		250 Vdc, 50 W resistive or 25W inductive (L/R=40ms)
Logic output operation time	< 7 ms	
Logic output mechanical durability	10000 operation minimum, loaded contact	
	100000 operation minimum, unloaded contact	

6 ACCURACY

Protection thresholds accuracy*	$I <, I_e <, I_2 < 2\% I_s$ or 5mA, the larger
---------------------------------	------------------------------------------------

Hysteresis	
CBF:	$0.9 I_s \pm 2\%$ or 5mA, the larger
Dead Zone:	$0.95 I_s \pm 2\%$ or 5mA, the larger
Pole Discrepancy	$0.95 I_s \pm 2\%$ or 5mA, the larger

Time delay (DT)	$\pm 2\%$ with a minimum of 10 ms					
Measurements	$\leq \pm 1\% @ I_n$					
Measurements pass band	500 Hz					
	The time delay does not take into account the opto-coupler input filtering and processing which is $20 \text{ ms} \pm 1 \text{ ms}$.					
Typical values are thus:						
	t setting =	0	20	50	200	1000 ms
	Trip =	20	40	70	220	$1020 \text{ ms} \pm 1 \text{ ms}$.
* Notes:						
On sample for 50 BF.						
On RMS values for Dead Zone and Pole Discrepancy.						

CBF current reset time	$I <, I_e < 15 \text{ ms}$ at 50 Hz, 12 ms at 60 Hz
	$I_2 < 15 \sim 28 \text{ ms}$ at 50 Hz, $12 \sim 23 \text{ ms}$ at 60 Hz

7 CT DATA

Phase CT primary	1 to 9999, step of 1
Earth CT primary	1 to 9999, step of 1
Phase CT secondary	1 or 5
Earth CT secondary	1 or 5
Phase inputs	5P10, 5 VA (typical)
Earth current	Residual connection or Core balanced CT (preferred in isolated and compensated neutral systems)

8 HIGH VOLTAGE WITHSTAND (INSULATION)

Dielectric withstand	IEC 60255-5: 2000	2 kV common mode
		1 kV differential mode
	ANSI/IEEE C37.90-1989 (reaffirmed 1994)	1.5 kV rms AC for 1 minute, across normally open contacts.
Impulse voltage	IEC 60255-5: 2000	5 kV common mode
		1 kV differential mode
Insulation resistance	IEC 60255-5: 2000	> 1000 M Ω

9 ELECTRICAL ENVIRONMENT (EMC)

9.1 High frequency disturbance

IEC 60255-22-1: 1988	2.5 kV common mode, class 3
	1 kV differential mode, class 3

9.2 Electrostatic discharge

EN 61000-4-2: 1995 and IEC 60255-22-2: 1996	8 kV contact discharge, class 4
	15 kV air discharge, class 4

9.3 Fast transient

IEC 60255-22-4: 2002, Class A	2kV 5kHz, terminal block comms.
	4kV 2.5kHz, all circuits excluding comms.
EN 61000-4-4: 1995, Level 4	4kV auxiliary power supply
	2kV 5kHz, all circuits excluding power supply

9.4 Surge

EN 61000-4-5:1995 and IEC 60255-22-5:2002	4kV common mode, Level 4
	2kV differential mode, Level 4

9.5 Conducted Emissions

EN 55022: 1998	0.15 - 0.5MHz, 79dB μ V (quasi peak) 66dB μ V (average)
	0.5 - 30MHz, 73dB μ V (quasi peak) 60dB μ V (average).

9.6 Radiated Emissions

EN 55022: 1998	30 - 230MHz, 40dB μ V/m at 10m measurement distance
	230 - 1GHz, 47dB μ V/m at 10m measurement distance.

9.7 Conducted Immunity

EN 61000-4-6:1996	Level 3, 10V rms @ 1kHz 80% am, 150kHz to 80MHz
-------------------	-------------------------------------------------

9.8 Radiated Immunity

EN 61000-4-3:2002	Level 3, 10V/m 80MHz to 1GHz @ 1kHz 80% am
ANSI/IEEE C37.90.2:2004	35V/m 80MHz to 1GHz @ 1kHz 80% am
	35V/m 80MHz to 1GHz @ 100% pulse modulated front face only.

9.9 Radiated immunity from digital telephones

EN 61000-4-3:2002	Level 4, 30V/m 800MHz to 960MHz and 1.4GHz to 2GHz @ 1kHz 80% am
-------------------	------------------------------------------------------------------

9.10 ANSI Surge Withstand Capability

IEEE/ANSI C37.90.1 2002	4kV fast transient and 2.5kV oscillatory applied common mode and differential mode
-------------------------	------------------------------------------------------------------------------------

9.11 Magnetic Field Immunity

IEC 61000-4-8: 1994	Level 5, 100A/m applied continuously, 1000A/m for 3s.
IEC 61000-4-9: 1993	Level 5, 1000A/m.
IEC 61000-4-10: 1993	Level 5, 100A/m at 100kHz and 1MHz.

10 ENVIRONMENT

10.1 Temperature

IEC 60068-2-1: 1993	Storage: -25°C to +70°C
IEC 60068-2-2: 1993	Operation: -25°C to +55°C
	-25°C to 70° (*)
(*) The upper limit is permissible for a single 6 hour duration within any 24 hour period.	
Tested as per IEC 60068-2-1: 2007	-25°C storage (96 hours)
	-40°C operation (96 hours)
As per IEC 60068-2-2: 2007	+85°C storage (96 hours)
	+85°C operation (96 hours)

10.2 Humidity

IEC 60068-2-78: 2001	56 days at 93% RH and 40°C
----------------------	----------------------------

10.3 Enclosure protection

IEC 60529: 2001	Dust IP50 (whole case), Front IP 52, Back IP 10
-----------------	-------------------------------------------------

10.4 Sinusoidal Vibrations

IEC 60255-21-1: 1998	Response and endurance, class 2
----------------------	---------------------------------

10.5 Shocks

IEC 60255-21-2: 1998	Response and endurance, class 2
----------------------	---------------------------------

10.6 Shock withstand & Bump

IEC 60255-21-2:1998	Response and withstand, class 1
---------------------	---------------------------------

10.7 Seismic

IEC 60255-21-3:1993	Class 2
---------------------	---------

10.8 Corrosive Environments

Per IEC 60068-2-60: 1995, Part 2, Test Ke, Method (class) 3	Industrial corrosive environment/poor environmental control, mixed gas flow test.
	21 days at 75% relative humidity and +30°C
	Exposure to elevated concentrations of H ² S, NO ² , Cl ² and SO ² .

11 EU DIRECTIVE

11.1 EMC Compliance

89/336/EEC

93/31/EEC

Compliance with European Commission EMC Directive.

Generic standards were used to establish conformity:

- EN50081-2: 1994
- EN60952-2: 1995

11.2 Product Safety

2006/95/EC (replacing 73/23/EEC from 01/2007)

Compliance with European Commission Low Voltage Directive (LVD). Compliance is demonstrated by reference to generic safety standards:

- EN61010-1: 1993/A2: 1995
- EN60950: 1992/A11: 1997

Notes

COMMUNICATIONS

MODBUS MAPPING, COURIER DATABASE,
IEC 60870-5-103 AND DNP3 DATABASE

CHAPTER 8

Date (month/year)	02/2016
Software Version	10.E
Hardware Suffix	Phase 2
Serial Number	Hardware installed

CONTENTS

Page (CT) 8-

1	MODBUS Protocol	7
1.1	MODBUS Communication Characteristics	7
1.1.1	MODBUS Network Characteristics	7
1.1.2	Parameters of the MODBUS Connection	8
1.1.3	Message Validity Check	8
1.1.4	Address of the MiCOM Relays	8
1.2	MODBUS Functions of MiCOM Relays	9
1.3	Presentation of Modbus Protocol	10
1.3.1	Frame Size Received by the P821 Relay	10
1.3.2	Format of Frames sent by the P821 Relay	10
1.3.3	Messages Validity Check	11
1.4	MODBUS Request Definition used to Retrieve Disturbance Records	12
1.4.1	Request the Number of Available Disturbance Records Saved in RAM.	12
1.4.2	Service Request	12
1.4.3	Request to Retrieve the Data of a Disturbance Record Channel	13
1.4.4	Request to Retrieve an Index Frame	13
1.5	MODBUS Request Definition used to Retrieve Event Records	14
1.5.1	Request to Retrieve the Oldest Non-Acknowledged Event	14
1.5.2	Request to Retrieve a Dedicated Event	14
1.6	MODBUS Request Definition used to Retrieve Fault Records	15
1.6.1	Request to Retrieve the Oldest Non-Acknowledged Fault Record	15
1.6.2	Request to Retrieve a Dedicated Fault Record	15
1.7	MiCOM P821 Database Organization	16
1.7.1	Description of the MODBUS Application Mapping	16
1.7.2	Page 0: Product Information, Remote Signalling and Remote Measurements	17
1.7.3	Page 1: Remote Settings	20
1.7.4	Page 2: Protective Functions - Remote Settings for Group 1.	25
1.7.5	Page 4: Remote Commands	25
1.7.6	Pages 5:	26
1.7.7	Page 6:	28
1.7.8	Page 7: Self Tests Results of the Relay	29
1.7.9	Page 8: Time Synchronisation	29
1.7.10	Page 9 to 21h: Disturbance Records Data (25 pages)	30
1.7.11	Meaning of each Value Channel	30
1.7.12	Calculation Formula for Phase Current Values	30
1.7.13	Calculation Formula for Earth Current Values	31
1.7.14	Page 22h: Disturbance Record Index Frame	32
1.7.15	Page 35h: Events Record	32
1.7.16	Page 36h: Oldest Event Data	33
1.7.17	Page 37h: 25 Last Fault Records Data	34
1.7.18	Pages 38h to 3Ch: Selection of the Disturbance Record and Channel	35

1.7.19	Page 3Dh: Number of Disturbance Records Available	36
1.8	Description of Mapping Format	38
<hr/>		
2	K-Bus Protocol and Courier Language	48
2.1	K-BUS	48
2.1.1	K-Bus Transmission Layer	48
2.1.2	K-Bus Connection	48
2.1.3	Auxiliary Equipment	49
2.2	Relay Courier Database	49
2.2.1	List of Events Generated by the Relay	49
2.3	Setting Changes	51
2.4	Systems Integration Data	52
2.4.1	Address of the Relay	52
2.4.2	Measured Values	52
2.4.3	Status Word	52
2.4.4	Unit Status Word	52
2.4.5	Control Status Word	53
2.4.6	Logic Input Status Word	53
2.4.7	Output Relay Status Word	53
2.4.8	Alarm Information	53
2.4.9	Protection Indication	54
2.4.10	Control and Supervision	55
2.4.11	Remote Change of Setting	55
2.5	Events Extraction	56
2.5.1	Automatic Event Extraction	56
2.5.2	Events Types	56
2.5.3	Event Format	56
2.5.4	Manual Record Extraction	57
2.6	Disturbance Record Extraction	57
2.7	Appendix 1	58
<hr/>		
3	IEC60870-5-103 Interface	77
3.1	Physical Connection and Link Layer	77
3.2	Initialization	77
3.3	Time Synchronization	78
3.4	Spontaneous Events	78
3.5	General Interrogation	78
3.6	Cyclic Measurements	78
3.7	Commands	78
3.8	Disturbance Records	79
3.9	Blocking of Monitor Direction	79
3.10	Appendix 2 - IEC 60870-5-103 Databases	79
3.10.1	List of Events Produced by the Relay	79
3.10.2	System State	82
3.11	Processed Commands	84

3.11.1	System Commands	84
3.11.2	General Commands (ASDU 20) (Control Direction)	84
3.12	Relay Re-Initialization	85
3.13	Cyclic Messages (ASDU 9 and ASDU 3)	85
3.14	IEC870-5-103 Messages for Disturbance Record Extraction	85
4	DNP 3.0 Configuration/Interoperability Guide	87
4.1	Introduction	87
4.2	DNP V3.00 Device Profile	87
4.3	Implementation Table	89
4.4	Point List	93
4.4.1	Binary Input Points	93
4.4.2	Binary Output Status Points and Control Relay Output Blocks	97
4.4.3	Counters	98
4.4.4	Analog Inputs	99

FIGURES

	Page (CT) 8-
Figure 1 - Access to network by query and response	7
Figure 2 - Access to network by broadcast message	7

TABLES

	Page (CT) 8-
Table 1 - Frame Transmitted by the Master (Query)	10
Table 2 - Frame Sent by the MiCOM Relay (Response)	10
Table 3 - Exception Frame sent by the Master (Response)	11
Table 4 - Disturbance record data	12
Table 5 - Service request data	12
Table 6 - Data retrieval request	13
Table 7 - Index frame retrieval request	13
Table 8 - Request to retrieval oldest non-acknowledged event	14
Table 9 - Request to retrieve dedicated event	14
Table 10 - Retrieval request for oldest non-acknowledged fault record	15
Table 11 - Retrieval request for dedicated fault record	15
Table 12 - Page numbers, contents and access	16
Table 13 - Page 0: Product Information, Remote Signalling and Remote Measurements	19

Table 14 - Page 1: Remote Settings	24
Table 15 - Breaker Failure Protection (P821)	25
Table 16 - Page 4: Remote Commands	25
Table 17 - Calibration (for Phase 1)	27
Table 18 - Boolean Logic Equation	28
Table 19 - Page 6:	28
Table 20 - Page 7: Self Tests Results of the Relay	29
Table 21 - Page 8: Time Synchronisation	29
Table 22 - Page 9 to 21h: Disturbance Records Data (25 pages)	30
Table 23 - Logic Channels	31
Table 24 - Page 22h: Disturbance Record Index Frame	32
Table 25 - Page 35h: Events Record	33
Table 26 - Page 36h: Oldest Event Data	33
Table 27 - Page 37h: 25 Last Fault Records Data	34
Table 28 - Pages 38h to 3Ch: Selection of the Disturbance Record and Channel	36
Table 29 - Page 3Dh: Number of Disturbance Records Available	36
Table 30 - Description of Mapping Format	47
Table 31 - List of Events generated by the Relay	51
Table 32 - Protection Indications of the cell 0023	54
Table 33 - Protection Indications of the cell 0024	54
Table 34 - Relay Courier Database	76
Table 35 - List of processed events	82
Table 36 - List of processed data	83
Table 37 - Relay re-initialization	85
Table 38 - Identifiers of tags (15) transmitted in ASDU 29 (logical informations)	86
Table 39 - DNP V3.00 - device profile document	89
Table 40 - Implementation Table	92
Table 41 - Binary Input Points	96
Table 42 - Binary Output Status Points and Control Relay Output Blocks	97
Table 43 - Binary Counters	98
Table 44 - Analog Inputs	100

1 MODBUS PROTOCOL

The MiCOM P821 relay offers MODBUS TM RTU mode communication through the rear RS485 port.

1.1 MODBUS Communication Characteristics

1.1.1 MODBUS Network Characteristics

The MODBUS protocol is based on the master-slave principle with the MiCOM P821 relay as slave.

The MODBUS protocol allows the master to read and to write one or several bits, one or several words and to remote the event logging data.

The access to the network can be:

- either according to a query and response

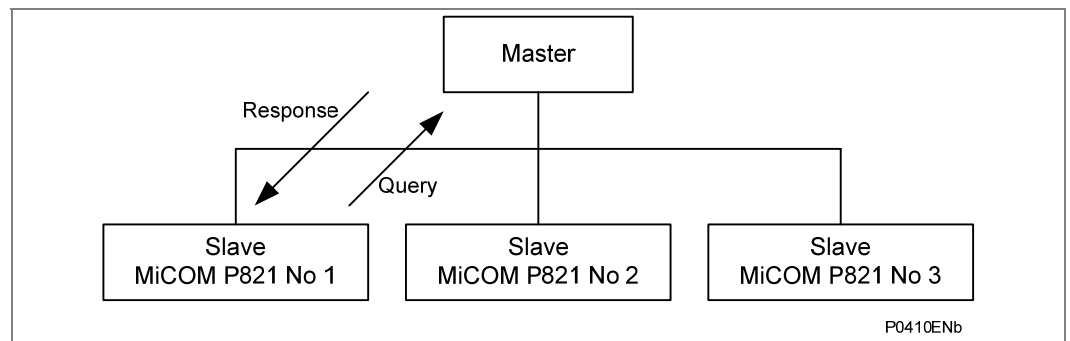

Figure 1 - Access to network by query and response

- or according to a broadcast message sent from the master to all the slaves.

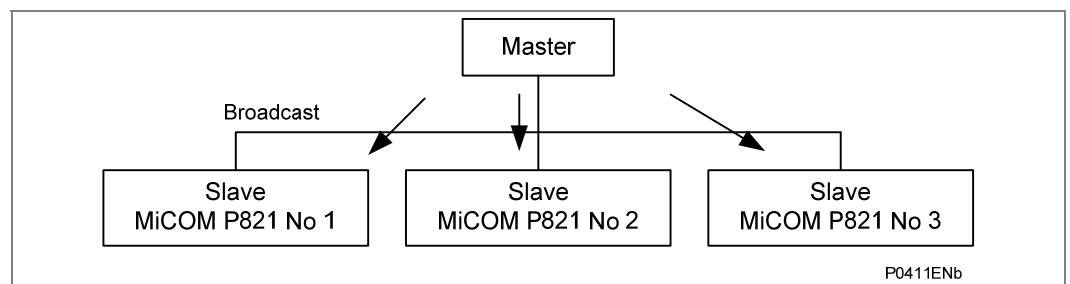

Figure 2 - Access to network by broadcast message

In that case:

- compulsory, the broadcast message is a writing order,
- the slaves return no response,
- the protocol is RTU mode. Each byte of the data frame is coded according to a hexadecimal base.
- At the end of each frame, two bytes of CRC16 validity checksum are applied on the whole of the frame content.

1.1.2 Parameters of the MODBUS Connection

The different parameters of the MODBUS connection are as follows:

- Isolated two-point RS485 connection (2 kV 50 Hz).
- MODBUS line protocol in RTU mode.
- The baud rate can be configured using the front panel of the relay:
 - Baud rate
 - 300
 - 600
 - 1200
 - 2400
 - 4800
 - 9600
 - 19200
 - 38400
 - From the operator interface the transmission mode parameters can be set as:
 - Transmission mode
 - 1 start / 8 bits / 1 stop: total 10 bits
 - 1 start / 8 bits / even parity / 1 stop: total 11 bits
 - 1 start / 8 bits / odd parity / 1 stop: total 11 bits
 - 1 start / 8 bits / 2 stop: total 11 bits

1.1.3 Message Validity Check

The validation of a frame is performed with a 16-bit cyclical redundancy check (CRC).

The generator polynomial is:

$$1 + x^2 + x^{15} + x^{16} = 1010\ 0000\ 0000\ 0001\ \text{binary} = A001\text{h}$$

1.1.4 Address of the MiCOM Relays

The address of MiCOM relays on the same MODBUS network can be between 1 and 255. Address 0 is reserved for broadcast messages.

1.2**MODBUS Functions of MiCOM Relays**

The MODBUS functions implemented on the MiCOM relays are:

- Function 1 or 2: Reading of n bits
- Function 3 or 4: Reading of n words
- Function 5: Writing of 1 bit
- Function 6: Writing of 1 word
- Function 7: Fast reading of 8 bits
- Function 8: Reading of the diagnosis counters
- Function 11: Reading of the Event counter
- Function 15: Writing of n bits
- Function 16: Writing of n words

1.3 Presentation of Modbus Protocol

MODBUS is a master-slave protocol whereby every exchange involves a master query and a slave response.

1.3.1 Frame Size Received by the P821 Relay

Frame Transmitted by the Master (Query):

Slave number	Function code	Information	CRC16
1 byte	1 byte	n bytes	2 bytes

Table 1 - Frame Transmitted by the Master (Query)

Slave Number:

The slave number should be the slave address between 1 and 255.

Function Code:

Requested MODBUS function (1 to 16).

Information:

Contains the parameters of the selected function.

CRC16:

Value of the CRC16 calculated by the master.

Note the MiCOM relay does not respond to globally broadcast frames sent out by the master.

1.3.2 Format of Frames sent by the P821 Relay

Frame sent by the MiCOM Relay (Response):

Slave number	Function code	Data	CRC16
1 byte	1 byte	n bytes	2 bytes

Table 2 - Frame Sent by the MiCOM Relay (Response)

Slave Number:

The slave number should be the slave address between 1 and 255.

Function Code:

Processed MODBUS function (1 to 16).

Data:

Contains the response data to the master query.

CRC16:

Value of the CRC16 calculated by the MiCOM relay.

1.3.3

Messages Validity Check

When the MiCOM relay receives a master query, it validates the frame:

- If the CRC is false, the frame is invalid. The MiCOM relay does not reply to the query. The master must retransmit its query. Excepting a broadcast message, this is the only case of non-reply by the MiCOM relay to a master query.
- If the CRC is correct but the MiCOM relay can not process the query, it sends to the master an exception response.

Exception Frame sent by the MiCOM Relay (Response):

Slave number	Function code	Error code	CRC16
1 byte	1 byte	1 byte	2 bytes

Table 3 - Exception Frame sent by the Master (Response)

Slave Number:

The slave number should be the slave address between 1 and 255.

Function Code:

The function code returned by the MiCOM relay in the exception frame is the code in which the most significant bit (bit7) is forced to 1.

Error Code:

Among the 8 exception codes of the MODBUS protocol, the MiCOM relay manages two of them:

- code 01: Unauthorised or unknown function code.
- code 03: A value of the data field is unauthorised (incorrect code).
- Control of pages being read.
- Control of pages being written.
- Control of address in pages.
- Length of request messages.

CRC16:

The CRC16 value is calculated by the slave.

1.4 MODBUS Request Definition used to Retrieve Disturbance Records

To retrieve a disturbance record, the following requests must be performed in exactly the following order:

1. (optional): Send a request to determine the number of disturbance records saved in RAM.
2. To retrieve the data of one channel:
 - a. (compulsory): Send a service request specifying the record number and the channel number to be retrieved.
 - b. (compulsory): Send requests to retrieve the data of a disturbance record channel as many times as needed.
 - c. (compulsory): send a request to retrieve the index frame.
3. Process the same operation (as described in the item 2) for each channel.

1.4.1 Request the Number of Available Disturbance Records Saved in RAM.

Slave number	Function code	Word address	Word number	CRC
xx	03h	3Dh 00	00 24h	xx xx

Table 4 - Disturbance record data

This request may be answered by an error message with the error code:

EVT_NOK (0F):No record available.

Note If there are less than 5 records available, the answer contains zero value in the non-used words.

1.4.2 Service Request

This is a request to retrieve the sample data of a disturbance record channel. It specifies the record number and the channel number which have to be retrieved. It determines the number of samples in the channel.

Slave number	Function code	Word address	Word number	CRC
xx	03h	Refer to mapping	00 0Bh	xx xx

Table 5 - Service request data

This request may be answered with error message. Two error codes are possible:

CODE_DEF_RAM (02):Saved RAM failure.

CODE_EVT_NOK (03): No disturbance record saved in RAM.

1.4.3

Request to Retrieve the Data of a Disturbance Record Channel

Slave number	Function code	Word address	Word number	CRC
xx	03h	Refer to mapping	1 to 7Dh	xx xx

Table 6 - Data retrieval request

This request may be answered with an error message. Two error codes are possible:

CODE_DEP_DATA (04): The requested sample number is higher than the number of samples in the specified channel.

CODE_SERV_NOK (05): The record number and the channel number have not been specified by a service request.

NOTE: This type of request can retrieve up to 125 words. A sample is coded in 1 word (16 bits).

1.4.4

Request to Retrieve an Index Frame

Slave number	Function code	Word address	Word number	CRC
xx	03h	22h 00	00 07h	xx xx

Table 7 - Index frame retrieval request

This event request may be answered an error message with the error code:

CODE_SERV_NOK (05): The record number and the channel number have not been specified by a service request.

1.5 MODBUS Request Definition used to Retrieve Event Records

There are two ways of retrieving an event record:

- Send a request to retrieve the oldest non-acknowledge event.
- Send a request to retrieve a dedicated event.

1.5.1 Request to Retrieve the Oldest Non-Acknowledged Event

Slave number	Function code	Word address	Word number	CRC
xx	03h	36h 00	00 09h	xx xx

Table 8 - Request to retrieval oldest non-acknowledged event

This event request may be answered by an error message with the error code:

EVT_EN_COURS_ECRIT (5): An event is being saved in RAM.

Note When an event is retrieved, the event record can be acknowledged in the following two ways:

Automatic Event Record Acknowledgement on Event Retrieval:

Bit 12 of the remote order frame (format F9 - mapping address 0400h) is set to 0. When the event is retrieved, this event record is acknowledged.

Non Automatic Event Record Acknowledgement on Event Retrieval:

Bit 12 of the remote order frame (format F9 - mapping address 0400h) is set to 1. When the event is retrieved, this event record is not acknowledged.

To acknowledge this event, another remote order is sent to the relay. Bit 13 of this frame (format F9 – mapping address 0400h) is set to 1.

1.5.2 Request to Retrieve a Dedicated Event

Slave number	Function code	Word address	Word number	CRC
xx	03h	Refer to mapping	00 09h	xx xx

Table 9 - Request to retrieve dedicated event

This event request may be answered an error message with the error code:

EVT_EN_COURS_ECRIT (5): An event is being written into the saved RAM.

Note This event retrieval does not acknowledge this event.

1.6 MODBUS Request Definition used to Retrieve Fault Records

There are two ways of retrieving a fault record:

- Send a request to retrieve the oldest non-acknowledged fault record.
- Send a request to retrieve a dedicated fault record.

1.6.1 Request to Retrieve the Oldest Non-Acknowledged Fault Record

Slave number	Function code	Word address	Word number	CRC
XX	03h	3Eh 00	00 0Fh	xx xx
When an event is retrieved, the fault record can be acknowledged in the following two ways: Automatic Fault Record Acknowledgement on Fault Retrieval Non Automatic Fault Record Acknowledgement on Fault Retrieval				

Table 10 - Retrieval request for oldest non-acknowledged fault record

Automatic Fault Record Acknowledgement on Fault Retrieval:

Bit 12 of the remote order frame (format F9 - mapping address 0400h) is set to 0. When the fault is retrieved, this fault record is acknowledged.

Non Automatic Fault Record Acknowledgement on Fault Retrieval:

Bit 12 of the remote order frame (format F9 - mapping address 0400h) is set to 1. On When the fault is retrieved, this fault record is not acknowledged.

To acknowledge this fault, another remote order shall be sent to the relay. Bit 14 of this frame (format F9 – mapping address 0400h) is set to 1.

1.6.2 Request to Retrieve a Dedicated Fault Record

Slave number	Function code	Word address	Word number	CRC
xx	03h	Refer to mapping	00 0Fh	xx xx

Note This fault value retrieval does not acknowledge this fault record.

Table 11 - Retrieval request for dedicated fault record

1.7 MiCOM P821 Database Organization

1.7.1 Description of the MODBUS Application Mapping

Pages 0 to 8: Contain the MiCOM P821 parameters.

Pages 9 to 3Dh: Contain the data of the event records, data of the fault value records, and data of the disturbance records, these pages are only available for MiCOM P821.

Pages 40h to 4Ah: Contain the data of the frequency disturbance records MiCOM P821.

These pages are explained in the following way:

Page No	Page Content	Access
Page 0	Information of product, remote signaling, remote measurements	Reading
Page 1	Remote settings for general parameters	Reading & writing
Page 2	Remote settings for protection group number 1	Reading & writing
Page 3	Remote settings for protection group number 2	Reading & writing
Page 4	Remote controls	Writing
Page 5	Relay Calibration Co-Efficients (for phase 1) Boolean Logic Equation (for phase 2)	Reading & writing
Page 6	Reserved	Not accessible
Page 7	Self tests results	Quick reading
Page 8	Date for synchronisation	Writing
Pages 9h to 21h	Disturbance record data (25 pages)	Reading
Page 22h	Index frame for the disturbance records	Reading
Pages 23h to 34h	Reserved	Not accessible
Page 35h	Event record data	Reading
Page 36h	Data of the oldest event	Reading
Page 37h	Fault record data	Reading
Pages 38h to 3Ch	Selection of the disturbance record and selection of its channel	Reading
Page 3Dh	Number of available disturbance records	Reading
Page 3Eh	Data of the oldest fault value record	Reading
Pages 40h to 4Ah	Data of the frequency disturbance records	Reading

Table 12 - Page numbers, contents and access

1.7.2 Page 0: Product Information, Remote Signalling and Remote Measurements

Read only access

Address	Group	Description	Settings range	Step	Unit	Format	Default settings
0000	Product information	Description of the relay characters 1 and 2	32 –127	1	-	F10	
0001		Description of the relay characters 3 and 4	32 –127	1	-	F10	P8
0002		Description of the relay characters 5 and 6	32 –127	1	-	F10	21
0003		Factory reference characters 1 and 2	32 –127	1	-	F10	Mi
0004		Factory reference characters 3 and 4	32 –127	1	-	F10	CO
0005		Software version	10 - xx	1	-	F21	10.A
0006		Front Communication type	0-3	1	-	F41	
0007		Phase internal ratio				F1	
0008		Earth internal ratio				F1	
0009 to 000C		Reserved					
000D		Active configuration group	1-2			F1	1
000E		Setting mode	0-1	1	-	F24	0
000F		Mains Power Supply Alarm				F45	

Address	Group	Description	Settings range	Step	Unit	Format	Default settings
0010	Remote signalling	Logic input	0 to 31	1	-	F12	
0011		Logic data	0 to FFFF	2n	-	F20	
0012		Internal logic	0 to FFFF	2n	-	F17	
0013		Output relays	0 to 511	1	-	F13	
0014		Phase A current & 50 BF flag			-	F33	
0015		Phase B current & 50 BF flag			-	F33	
0016		Phase C current & 50 BF flag			-	F33	
0017		50 BF flag		1	-	F31	
0018		Security flag	0 to 3		-	F32	
0019		CB problem flag	0 to 1	1	-	F34	
001A		Aux. Inputs flag			-	F54	
001B		Relay 1 data	0 to 1	1	-	F1	
001C		Number of disturbance records	0 to 5	1	-	F55	
001D		Earth current & 50BF flag			-	F33	
001E		Alarm flag1 memo	0 to FFFF		-	F65	
001F		Earth current & 50BF flag memorisation				F33	
0020		Security 1 & 2 flag memorisation				F32	
0021		Phase A current & 50BF flag memorisation				F33	
0022		Phase B current & 50BF flag memorisation				F33	

Address	Group	Description	Settings range	Step	Unit	Format	Default settings
0010	Remote signalling	Logic input	0 to 31	1	-	F12	
0023		Phase C current & 50BF flag memorisation				F33	
0024		50 BF triphase alarm flag memorisation			-	F31	
0025		End fault alarm flag memorisation			-	F37	
0026		Pole discrepancy alarm flag memorisation			-	F38	
0027		Aux. 1 & 2 alarms flag memorisation				F40	
0028		End fault function data			-	F35	
0029		Pole discrepancy function data			-	F36	
002A		50 BF supervision flag			-	F46	
002B		50 BF supervision alarms memorisation			-		
002C		Statistic reset			-		
002D		Negative current & 50BF flag memorisation	0 to FFFF		-	F33	
002E		Output relays latch memorisation	0 to FFFF			F13	
002F		Output relays latch reset	0 to FFFF			F1	
003D		Phase Non I flag	0 to FFFF			F13	
003E		Earth Non I flag	0 to FFFF			F13	
003F		Negative Non I flag	0 to FFFF			F13	
0040		Boolean Equation Status Flags	0 to FFFF			F61	
0041 to 004F		Reserved					

Address	Group	Description	Settings range	Step	Unit	Format	Default settings	Product P821
0030	Remote Measurements	True RMS phase current IA	0 to 600 000	1	A/100	F18		X
0032		True RMS phase current IB	0 to 600 000	1	A/100	F18		X
0034		True RMS phase current IC	0 to 600 000	1	A/100	F18		X
0036		True RMS earth current	0 to 600 000	1	A/100	F18		X
0038		Reserved						
003A		Reserved						
003B		Frequency	4500 to 6500	1	1/100 Hz	F1		X
003C		Logic data(word 2)	0 to FFFF			F20'		
0058		Negative Phase Sequence Current Value (Fundamental)	0 to 6000 000			F18		X

Address	Group	Description	Settings range	Step	Unit	Format	Default settings	Product P821
0050	Fourier Module	Module IA			-	F1		X
0051		Module IB			-	F1		X
0052		Module IC			-	F1		X

Address	Group	Description	Settings range	Step	Unit	Format	Default settings	Product P821
0050	Fourier Module	Module IA			-	F1		X
0053		Module Ie			-	F1		X
005A		Module I2				F1		

Address	Group	Description	Settings range	Step	Unit	Format	Default settings	Product P821
0054	Fourier Argument	Argument IA			-	F1		X
0055		Argument IB			-	F1		X
0056		Argument IC			-	F1		X
0057		Argument Ie			-	F1		X
005B to 005F		Reserved						

Address	Group	Description	Settings range	Step	Unit	Format	Default settings
0060	Statistics	Number of external Triphase Trip				F1	
0061		Number of external Phase A Trip				F1	
0062		Number of external Phase B Trip				F1	
0063		Number of external Phase C Trip				F1	
0064		Number of Phase A Retrip				F1	
0065		Number of Phase B Retrip				F1	
0066		Number of Phase C Retrip				F1	
0067		Number of Stage 1 Retrip				F1	
0068		Number of Stage 2 Backtrip				F1	
0069		Number of Earth Retrip				F1	
006A		Number of Neg. Retrip				F1	
006B		Number of CB unh Retrip				F1	
006C		Number of CB unh Backtrip				F1	
006D		Number of external Non I Trip				F1	
006E		Number of Extern Phase Non I Retrip				F1	
006F		Number of Extern Earth Non I Retrip				F1	
0070		Number of Extern Neg. Non I Retrip				F1	
0071		Number of external Non I BackTrip				F1	
0072		Number of external Non I Retrip				F1	
0073		Auxiliary Power Supply alarm				F98	
0074		Transformer Offset alarm				F99	
0075 to 00EF		Reserved					
00F0		Model Number					
00F8		Serial Number					

Table 13 - Page 0: Product Information, Remote Signalling and Remote Measurements

1.7.3 Page 1: Remote Settings

Read and write access

Address	Group	Description	Settings range	Step	Unit	Format	Default settings
0100	Remote settings	Address	1 to 255	1	-	F1	1
0101		Language	0 to 7	-	-	F1	-
0102		Password characters 1 and 2	32 -127	1	-	F10	AA
0103		Password characters 3 and 4	32 -127	1	-	F10	AA
0104		Frequency	50-60	10	Hz	F1	50
0105		Phase A Labelling	L1 – A - R	VTA		F25	A
0106		Phase B Labelling	L2 – B - S	VTA		F25	B
0107		Phase C Labelling	L3 – C - T	VTA		F25	C
0108		Earth Labelling	N – E - o	VTA		F25	N
0109		Default display	1-3	1	-	F26	1
010A		User reference (characters 1 and 2)	32-127	1		F10	AL
010B		User reference (characters 3 and 4)	32-127	1		F10	ST
010C		Fault number to be displayed	1-5	1		F49	5
010D		Configuration of the logic inputs validation edge		0		F11	0
010E		Reserved					
010F		Type of the logic inputs input voltage	0-1	1		F50	0

Address	Group	Description	Settings range	Step	Unit	Format	Default settings
	CB supervision						
0110		CB operation number		1		F1	
0111		CB operating time		1	1/10 sec	F1	
0112 to 0113		San IA			An	F18	
0113 to 0114		San IB			An	F18	
0114 to 0115		San IC			An	F18	
0118		Wiring security	0 - 1	1		F52	
0119		Relay to test 1	1 - 8	1		F53	
011A		Relay to test 1	1 - 8	1		F53	
011B to 011E		Reserved					
011F		Latched relays				F14	

Address	Group	Description	Settings range	Step	Unit	Format	Default settings
	Ratios						
0120		Phase CT: primary value	1 to 50000	1		F1	1000

Address	Group	Description	Settings range	Step	Unit	Format	Default settings
Ratios							
0121		Phase CT: secondary value	1 to 5	4		F1	1
0122	Trip relay allocation	Trip relay functionality (word 1)	0 to 65535	1		F6	
0123	Latching	Trip relay latching function (word 1)	0 to 255	1	10 V	F8	
0124	Ratio	Earth CT: primary value	1 to 50000	1		F1	1000
0125		Earth CT: secondary value	1 to 5	4		F1	1
0126		Trip relay functionality (word 2)	0 to 65535	1		F6'	
0127	Latching	Trip relay latching function (word 2)	0 to 65535	1		F8'	
0128 to 012F		Reserved					

Address	Group	Description	Settings range	Step	Unit	Format	Default settings
Communication							
0130		Baud rate	0 to 7	1	-	F4	6 = 19200 bauds
0131		Parity	0 to 2	1	-	F5	0 = without
0132		Data bits	0 to 1	1		F28	1 = 8 bits
0133		Number of stop bits	0 to 1	1	-	F29	0 = 1 stop bit
0134		Comm. Available	0 to 1	1	-	F30	1 = COM available
0135		Date Format	0 to 1	0		F48	0 = Private
0136		Reserved					
0137		AddressRear Port					
0138 to 013F		Reserved					

Address	Group	Description	Settings range	Step	Unit	Format	Default settings
0140	Setting group	Active setting group	1 to 2	1	-	F1	1
0141		Validation of instantaneous self resetting	0 to 1	1		F1	0
0142		Configuration of the change of the setting group	0 to 1	1		F47	1
0143		Configuration of Battery and RAM error alarms	0 to 1	1		F1	0
0144		conf. TS AC/DC visible					
0145 to 014F		Reserved					

Address	Group	Description	Settings range	Step	Unit	Format	Default settings
0150	LEDs configuration	LED 5 (Word 1)		1	-	F19	0
0151		LED 6 (Word 1)		1	-	F19	

Address	Group	Description	Settings range	Step	Unit	Format	Default settings
0150	LEDs configuration	LED 5 (Word 1)		1	-	F19	0
0152		LED 7 (Word 1)		1	-	F19	
0153		LED 8 (Word 1)		1		F19	
0154		LED 5 (Word 2)		1		F19'	
0155		LED 6 (Word 2)		1		F19'	
0156		LED 7 (Word 2)		1		F19'	
0157		LED 8 (Word 2)		1		F19'	0
0158		LED 5 (Word 3)				F19''	
0159		LED 6 (Word 3)				F19''	
015A		LED 7 (Word 3)				F19''	
015B		LED 8 (Word 3)				F19''	
015C to 015F		Reserved					

Address	Group	Description	Settings range	Step	Unit	Format	Default settings
0160	Logic inputs configuration	Logic input 1 (Word 1)	VTA	1	-	F15	0
0161		Logic input 2 (Word 1)	VTA	1	-	F15	0
0162		Logic input 3 (Word 1)	VTA	1	-	F15	0
0163		Logic input 4 (Word 1)	VTA	1	-	F15	0
0164		Logic input 5 (Word 1)	VTA	1	-	F15	0
019A		Logic input 1 (Word 2)	VTA	1	-	F15'	0
019B		Logic input 2 (Word 2)	VTA	1	-	F15'	0
019C		Logic input 3 (Word 2)	VTA	1	-	F15'	0
019D		Logic input 4 (Word 2)	VTA	1	-	F15'	0
019E		Logic input 5 (Word 2)	VTA	1	-	F15'	0
0165		Aux. Timer 1	0 to 20000	1	1/100 s	F1	0
0166		Aux. Timer 2	0 to 20000	1	1/100 s	F1	0

Address	Group	Description	Settings range	Step	Unit	Format	Default settings
0167	Allocation of information to auxiliary output contact (RL2 to RL8)	Phase A Retrip (DTA')	0 to 7F	1	-	F14	0
0168		Phase B Retrip (DTA')	0 to 7F	1	-	F14	0
0169		Phase C Retrip (DTA')	0 to 7F	1	-	F14	0
016A		Retrip 1 st stage (DTA' DTB' DTC')	0 to 7F	1	-	F14	0
016B		General retrip (DTG)	0 to 7F	1	-	F14	0
016C		End fault protection (T_DZ)	0 to 7F	1	F14		0
016D		3 poles discrepancy	0 to 7F	1	-	F14	0
016E		Taux 1	0 to 7F	1	-	F14	0

Address	Group	Description	Settings range	Step	Unit	Format	Default settings
0167	Allocation of information to auxiliary output contact (RL2 to RL8)	Phase A Retrip (DTA')	0 to 7F	1	-	F14	0
016F		Taux 2	0 to 7F	1	-	F14	0

Address	Group	Description	Settings range	Step	Unit	Format	Default settings	Product P821
0170	Allocation of information to auxiliary output contact (RL2 to RL8)	Trip	0 - 7 or 0 - 127	1	-	F14	0	X
0170	Disturbance records	Pre-time	1 to 30	1	1/10 sec	F1	1	X
0171		Post-time (phase 1 only)	1 to 30	1	1/10 sec	F1	1	X
0172		Disturbance record (Trigger Configuration)	0 to 1	1	-	F22	0	X

Address	Group	Description	Settings range	Step	Unit	Format	Default settings	Product P821
0173	CB supervision	Operating time	0-1	1	-	F44	0	X
0174		Operating time threshold	10 to 500	1	1/100 sec	F1	1	X
0175		Number of operations	0-1	1	-	F44	0	X
0176		Max number of the CB operation	0 to 50000	1	-	F1	0	X
0177		SAn summation	0 - 1	1	-	F44	0	X
0178		SAn summation threshold	0 to 4000	10E6	10e6 An			X
0179		n	1 to 2	1		F1	1	X
017A		Tripping pulse	10 to 500	10	1/100 sec	F1	10	X

Address	Group	Description	Settings range	Step	Unit	Format	Default settings	Product P821
017B	Relay allocation	1st stage Earth Retrip (DTE')	0 - 7F	1	-	F14	0	X
017C		Opening time on external order	0 - 7F	1		F14	0	X
017D		Number of tripping operation threshold	0 - 7F	1		F14	0	X
017E		SAn threshold	0 - 7F	1		F14	0	X
017F		Stage 1 opening time threshold	0 - 7F	1		F14	0	X
0180 to 0187		Reserved						
0188		Phase Non I stage1	0 - 7F	1		F14		
0189		Earth Non I stage1	0 - 7F	1		F14		

Address	Group	Description	Settings range	Step	Unit	Format	Default settings	Product P821
017B	Relay allocation	1st stage Earth Retrip (DTE')	0 - 7F	1	-	F14	0	X
018A		Negative Non I stage1	0 - 7F	1		F14		
018B		t Equ. A	0 - FFFF			F14		
018C		t Equ. B	0 - FFFF			F14		
018D		t Equ. C	0 - FFFF			F14		
018E		t Equ. D	0 - FFFF			F14		
018F		t Equ. E	0 - FFFF			F14		
0190		t Equ. F	0 - FFFF			F14		
0191		t Equ. G	0 - FFFF			F14		
0192		t Equ. H	0 - FFFF			F14		
0193		Non I stage1	0 - 7F	1		F14		
0194		Non I stage2	0 - 7F	1		F14		
0195		Negative stage1	0 - 7F	1		F14		
0196		CB Unhealthy stage1	0 - 7F	1		F14		
0197		CB Unhealthy stage2	0 - 7F	1		F14		
0198		Blokc Logic 1	0 - FFFF			F66		
0199		Blokc Logic 2	0 - FFFF			F66		
019F to 01F3		Reserved						

Table 14 - Page 1: Remote Settings

1.7.4 Page 2: Protective Functions - Remote Settings for Group 1.

Breaker Failure Protection (P821)

Address	Group	Description	Settings range	Step	Unit	Format	Default settings
0200	Setting group n°1	Breaker Failure	0-1	1	-	F24	0
0201		Threshold I<	5 to 400	1	In/100	F1	10
0202		TBF1 delay	0 to 4000	5	1/1000 s	F1	10
0203		TBF2 delay	0 to 4000	5	1/10	F1	40
0204		1st stage Reset	0 - 1	1		F27	0
0205		End fault	0 - 1	1		F42	0
0206		I_DZ> threshold	5 - 400	1	In/100	F1	100
0207		DZ delay	0 to 40000	5	1/1000 s	F1	10
0208		Pole Discrepancy	0 - 1	1		F43	0
0209		I_PD> Threshold	8 - 400	1	In/100	F1	80
020A		I_PD< Threshold	5 - 100	1	In/100	F1	40
020B		PD Delay	0 to 40000	5	1/1000 s	F1	10
020C		Phase Breaker failure	0-1	1		F56	0
020D		Earth Breaker failure	0-1	1		F57	0
020E		I0< Threshold	N: 5 to 400 S: 1 to 400 VS: 2 to 800	1	In/100 In/100 In/1000	F1	N: 10 S: 5 VS: 25
020F		Phase Delay stage 1	0 to 40000	5	1/1000 s	F1	
0210		Phase Delay stage 2	0 to 40000	5	1/1000 s	F1	
0211		CB Fail Neg. Seq.	0 to 1	1		F24	
0212		I2< BF	5 to 200	1	1/100	F1	
0213		Neg. Delay stage 1	0 to 40000	5	1/1000 s	F1	
0214		Neg. Delay stage 2	0 to 40000	5	1/1000 s	F1	
0215		CB unhealthy	0 to 1	1		F24	
0216		CB unh. stage 1	0 to 40000	5	1/1000 s	F1	
0217		CB unh. stage 2	0 to 40000	5	1/1000 s	F1	
0218		Ie DZ>threshold	N: 5 to 400 S: 1 to 400 VS: 2 to 800	1	In/100 In/100 In/1000	F1	
0219		External Non I Reset by	0 to 2	1		F62	

Table 15 - Breaker Failure Protection (P821)

1.7.5 Page 4: Remote Commands

Writing only access

Address	Group	Description	Settings group	Step	Unit	Format	Default settings
0400	Remote control	Remote control word 1	0 to 31	1	-	F9	0
0401		Calibration mode					0
0402		Remote control word 2	0 to FFFF	2N	-	F51	0
0403		Remote control word 3	0 to FFFF	2N	-	F63	

Table 16 - Page 4: Remote Commands

1.7.6

Pages 5:

This page is used for Calibration in phase 1 relay and for Boolean Logic Equation in phase 2 relay.

Calibration (for Phase 1)

Read and Write access on testing bench

Address	Group	Description	Settings group	Step	Unit	Format	Default settings
0500	1 Amp Calibration	Calibration Coeff. Ia for Gain 1	0 -65535	1	-	F1	0
0501		Coeff Ia Gain 2	0 -65535	1	-	F1	0
0502		Coeff Ia Gain 4	0 -65535	1	-	F1	0
0503		Coeff Ia Gain 16	0 -65535	1	-	F1	0
0504		R/L for Ia	0-65535	1	-	F1	1
0505		Coef Ib gain 1	0-65535	1	-	F1	0
0506		Coef Ib gain 2	0 -65535	1	-	F1	0
0507		Coef Ib gain 4	0 -65535	1	-	F1	0
0508		Coef Ib gain 16	0-65535	1	-	F1	0
0509		R/L for Ib	0-65535	1	-	F1	1
050A		Coef Ic gain 1	0-65535	1	-	F1	0
050B		Coef Ic gain 2	0-65535	1	-	F1	0
050C		Coef Ic gain 4	0-65535	1	-	F1	0
050D		Coef Ic gain 16	0-65535	1	-	F1	0
050E		R/L for Ic	0-65535	1	-	F1	1
050F		Coef I0 gain 1	0-65535	1	-	F1	0
0510		Coef I0 gain 2	0-65535	1	-	F1	0
0511		Coef I0 gain 4	0-65535	1	-	F1	0
0512		Coef I0 gain 16	0-65535	1	-	F1	0
0513		R/L for I0	0-65535	1	-	F1	1
0514	5 Amp Calibration	Calibration Coeff. Ia for Gain 1	0 -65535	1	-	F1	0
0515		Coeff Ia Gain 2	0 -65535	1	-	F1	0
0516		Coeff Ia Gain 4	0 -65535	1	-	F1	0
0517		Coeff Ia Gain 16	0 -65535	1	-	F1	0
0518		R/L for Ia	0-65535	1	-	F1	1
0519		Coef Ib gain 1	0-65535	1	-	F1	0
051A		Coef Ib gain 2	0 -65535	1	-	F1	0
051B		Coef Ib gain 4	0 -65535	1	-	F1	0
051C		Coef Ib gain 16	0-65535	1	-	F1	0
051D		R/L for Ib	0-65535	1	-	F1	1
051E		Coef Ic gain 1	0-65535	1	-	F1	0
051F		Coef Ic gain 2	0-65535	1	-	F1	0
0520		Coef Ic gain 4	0-65535	1	-	F1	0
0521		Coef Ic gain 16	0-65535	1	-	F1	0
0522		R/L for Ic	0-65535	1	-	F1	1

Address	Group	Description	Settings group	Step	Unit	Format	Default settings
0500	1 Amp Calibration	Calibration Coeff. Ia for Gain 1	0-65535	1	-	F1	0
0523		Coef I0 gain 1	0-65535	1	-	F1	0
0524		Coef I0 gain 2	0-65535	1	-	F1	0
0525		Coef I0 gain 4	0-65535	1	-	F1	0
0526		Coef I0 gain 16	0-65535	1	-	F1	0
0527		R/L for I0	0-65535	1	-	F1	1
0528-0529		Serial number	0 – 0xffffffff				
052A		Valid calibration flag	0 - 1	0			
052B		Product Type	12850 or 12851 22 or 23 in ascii	0			

Table 17 - Calibration (for Phase 1)

Boolean Logic Equation

Address	Group	Description	Settings group	Step	Unit	Format	Default settings
0500	Boolean Equation A	Equation A Operator 0	0 - FFFF	1	-	F59	0
0501		Equation A Operand 0	0 - FFFF	1	-	F58	0
0502		Equation A Operator 1	0 - FFFF	1	-	F59	0
0503		Equation A Operand 1	0 - FFFF	1	-	F58	0
0504		Equation A Operator 2	0 - FFFF	1	-	F59	0
0505		Equation A Operand 2	0 - FFFF	1	-	F58	0
0506		Equation A Operator 3	0 - FFFF	1	-	F59	0
0507		Equation A Operand 3	0 - FFFF	1	-	F58	0
0508		Equation A Operator 4	0 - FFFF	1	-	F59	0
0509		Equation A Operand 4	0 - FFFF	1	-	F58	0
050A		Equation A Operator 5	0 - FFFF	1	-	F59	0
050B		Equation A Operand 5	0 - FFFF	1	-	F58	0
050C		Equation A Operator 6	0 - FFFF	1	-	F59	0
050D		Equation A Operand 6	0 - FFFF	1	-	F58	0
050E		Equation A Operator 7	0 - FFFF	1	-	F59	0
050F		Equation A Operand 7	0 - FFFF	1	-	F58	0
0510		Equation A Operator 8	0 - FFFF	1	-	F59	0
0511		Equation A Operand 8	0 - FFFF	1	-	F58	0
0512		Equation A Operator 9	0 - FFFF	1	-	F59	0
0513		Equation A Operand 9	0 - FFFF	1	-	F58	0
0514		Equation A Operator 10	0 - FFFF	1	-	F59	0
0515		Equation A Operand 10	0 - FFFF	1	-	F58	0
0516		Equation A Operator 11	0 - FFFF	1	-	F59	0
0517		Equation A Operand 11	0 - FFFF	1	-	F58	0
0518		Equation A Operator 12	0 - FFFF	1	-	F59	0
0519		Equation A Operand 12	0 - FFFF	1	-	F58	0

Address	Group	Description	Settings group	Step	Unit	Format	Default settings
051A		Equation A Operator 13	0 - FFFF	1	-	F59	0
051B		Equation A Operand 13	0 - FFFF	1	-	F58	0
051C		Equation A Operator 14	0 - FFFF	1	-	F59	0
051D		Equation A Operand 14	0 - FFFF	1	-	F58	0
051E		Equation A Operator 15	0 - FFFF	1	-	F59	0
051F		Equation A Operand 15	0 - FFFF	1	-	F58	0
0520~053F	Boolean Equation B						
0540~055F	Boolean Equation C						
0560~057F	Boolean Equation D						
0580~059F	Boolean Equation E						
05A0~05BF	Boolean Equation F						
05C0~05DF	Boolean Equation G						
05E0~05FF	Boolean Equation H						

Table 18 - Boolean Logic Equation

1.7.7

Page 6:

Page 6 is reserved in phase 1 but used for Boolean Logic Equation Timers in phase 2.

Address	Group	Description	Settings group	Step	Unit	Format	Default settings
0600	Boolean Equation Timers	Equation A Rising Timer	0 to 60000	1	1/100s	F1	0
0601		Equation A Falling Timer	0 to 60000	1	1/100s	F1	0
0602		Equation B Rising Timer	0 to 60000	1	1/100s	F1	0
0603		Equation B Falling Timer	0 to 60000	1	1/100s	F1	0
0604		Equation C Rising Timer	0 to 60000	1	1/100s	F1	0
0605		Equation C Falling Timer	0 to 60000	1	1/100s	F1	0
0606		Equation D Rising Timer	0 to 60000	1	1/100s	F1	0
0607		Equation D Falling Timer	0 to 60000	1	1/100s	F1	0
0608		Equation E Rising Timer	0 to 60000	1	1/100s	F1	0
0609		Equation E Falling Timer	0 to 60000	1	1/100s	F1	0
060A		Equation F Rising Timer	0 to 60000	1	1/100s	F1	0
060B		Equation F Falling Timer	0 to 60000	1	1/100s	F1	0
060C		Equation G Rising Timer	0 to 60000	1	1/100s	F1	0
060D		Equation G Falling Timer	0 to 60000	1	1/100s	F1	0
060E		Equation H Rising Timer	0 to 60000	1	1/100s	F1	0
060F		Equation H Falling Timer	0 to 60000	1	1/100s	F1	0
0610 to 062F		Reserved					

Table 19 - Page 6:

1.7.8 Page 7: Self Tests Results of the Relay

Quick reading access only

Address	Group	Description	Settings group	Step	Unit	Format	Default settings
0700	Protection Status	Description of the protection autocontrols		1	-	F23	0

Table 20 - Page 7: Self Tests Results of the Relay

1.7.9 Page 8: Time Synchronisation

Time synchronisation: access in writing for n words (function 16). The time synchronisation format is based on 8 bits (4 words).

If date Format (0135h) is private date then format is:

Timer	@page	Nb bits	Values range	Unit
Year pF + pf	8	2		year
Month	8	1	1 - 12	month
Day	8	1	1 - 31	day
Hour	8	1	0 - 23	hour
Minute	8	1	0 - 59	minute
Millisecond pF + pf	8	2	0 - 59999	ms

Else format is (Inverted IEC 870-5-4 CP56Time2a):

Timer	@page	Nb bits	Values range	Unit
	8	1	0	
Year	8	1	0 – 99	Year
Month	8	1	1 – 12	Month
Day of Week / Day of Month	8	1	1 – 12 1 – 31	Day
Summer time / 00/ Hour	8	1	0 – 1 / 00 / 0 – 23	Hour
Invalidity/ Minute	8	1	0-1 / 0 / 0 – 59	Minute
Millisecond pF+pf	8	2	0 – 59999	Ms

Table 21 - Page 8: Time Synchronisation

1.7.10

Page 9 to 21h: Disturbance Records Data (25 pages)

Disturbance records data (25 pages). Access in words writing, each disturbance mapping page contains 250 words.

Address	Contents
0900 to 09FAh	250 disturbance data words
0A00 to 0AFAh	250 disturbance data words
0B00 to 0BFAh	250 disturbance data words
0C00 to 0CFAh	250 disturbance data words
0D00 to 0DFAh	250 disturbance data words
0E00 to 0EFAh	250 disturbance data words
0F00 to 0FFAh	250 disturbance data words
1000 to 10FAh	250 disturbance data words
1100 to 11FAh	250 disturbance data words
1200 to 12FAh	250 disturbance data words
1300 to 13FAh	250 disturbance data words
1400 to 14FAh	250 disturbance data words
1500 to 15FAh	250 disturbance data words
1600 to 16FAh	250 disturbance data words
1700 to 17FAh	250 disturbance data words
1800 to 18FAh	250 disturbance data words
1900 to 19FAh	250 disturbance data words
1A00 to 1AFAh	250 disturbance data words
1B00 to 1BFAh	250 disturbance data words
1C00 to 1CFAh	250 disturbance data words
1D00 to 1DFAh	250 disturbance data words
1E00 to 1EFAh	250 disturbance data words
1F00 to 1FFAh	250 disturbance data words
2000 to 20FAh	250 disturbance data words
2170 to 21FAh	250 disturbance data words

Note *The disturbance data pages contain values of one channel from one given disturbance record.*

Table 22 - Page 9 to 21h: Disturbance Records Data (25 pages)

1.7.11

Meaning of each Value Channel

- IA, IB, IC and I₀ channels:

The value is a signed 16 bits word equivalent to the ADC value.

1.7.12

Calculation Formula for Phase Current Values

Line phase current value (primary value) = phase sampled value (e.g. word 10, 11, 12 or 13) * phase primary CT / phase internal CT ratio (mapping address 0007) *√2

1.7.13

Calculation Formula for Earth Current Values

The formula depends on nominal earth current:

- 0.1 to 40 Ion Range
- 0.01 to 8 Ion Range
- 0.002 to 1 Ion Range

0.1 to 40 Ion Range

Line earth current value (primary value) = earth sampled value (e.g. word 10 or 14) * earth primary CT / earth internal CT ratio (mapping address 0008=800) *√2

0.01 to 8 Ion Range

Line earth current value (primary value) = earth sampled value (e.g. word 10 or 14) * earth primary CT / earth internal CT ratio (mapping address 0008=3277) *√2

0.002 to 1 Ion Range

Line earth current value (primary value) = earth sampled value (e.g. word 10 or 14) * earth primary CT / earth internal CT ratio (mapping address 0008=32700) *√2

- Frequency channel:

Time between two samples in microseconds

- Logic channels:

Logic Channel	Contents
Bit 0	Trip relay (RL1)
Bit 1	Output relay 2 (RL2)
Bit 2	Output relay 3 (RL3)
Bit 3	Output relay 4 (RL4)
Bit 4	Watch-dog relay (RL0)
Bit 5	Output relay 5 (RL5)
Bit 6	Output relay 6 (RL6)
Bit 7	Output relay 7 (RL7)
Bit 8	Output relay 8 (RL8)
Bit 9	Reserved
Bit 10	Logic input 1 (EL1)
Bit 11	Logic input 2 (EL2)
Bit 12	Logic input 3 (EL3)
Bit 13	Logic input 4 (EL4)
Bit 14	Logic input 5 (EL5)
Bit 15	Reserved

Table 23 - Logic Channels

1.7.14

Page 22h: Disturbance Record Index Frame

Read access only.

Address	Contents
2200h	Disturbance data index frame

Disturbance record index frame.

Word	Contents
n° 1	Disturbance record number
n° 2	Disturbance record finish date (second)
n° 3	Disturbance record finish date (second)
n° 4	Disturbance record finish date (millisecond)
n° 5	Disturbance record finish date (millisecond)
n° 6	Disturbance record starting condition: 1: tripping command (RL1) 2: instantaneous 3: remote command 4: logic input
n° 7	Frequency at the post-time beginning
n° 8	(=0) Optional
n° 9	(=0) Optional

Table 24 - Page 22h: Disturbance Record Index Frame

1.7.15

Page 35h: Events Record

Read access only.

Event record data (9 words):

Word n° 1: Event meaning

Word n° 2: MODBUS associated value

Word n° 3: MODBUS address

Word n° 4: COURIER Cell address

Words n° 5 & 6 if data format is private:

Event date (second) number of seconds since 01/01/94

Words n° 7 & 8 if data format is private:

Event date (millisecond)

Words N°5, 6, 7, 8, if data format is Inverted IEC 870-5-4 CP56Time2a

Word n° 9: Acknowledge

0=event non acknowledged

1= event acknowledged

Address	Contents	Address	Contents	Address	Contents
3500h	EVT n°1	351Ah	EVT n°27	3534h	EVT n°53
3501h	EVT n°2	351Bh	EVT n°28	3535h	EVT n°54
3502h	EVT n°3	351Ch	EVT n°29	3536h	EVT n°55
3503h	EVT n°4	351Dh	EVT n°30	3537h	EVT n°56
3504h	EVT n°5	351Eh	EVT n°31	3538h	EVT n°57
3505h	EVT n°6	351Fh	EVT n°32	3539h	EVT n°58
3506h	EVT n°7	3520h	EVT n°33	353Ah	EVT n°59
3507h	EVT n°8	3521h	EVT n°34	353Bh	EVT n°60
3508h	EVT n°9	3522h	EVT n°35	353Ch	EVT n°61
3509h	EVT n°10	3523h	EVT n°36	353Dh	EVT n°62
350Ah	EVT n°11	3524h	EVT n°37	353Eh	EVT n°63
350Bh	EVT n°12	3525h	EVT n°38	353Fh	EVT n°64
350Ch	EVT n°13	3526h	EVT n°39	3540h	EVT n°65
350Dh	EVT n°14	3527h	EVT n°40	3541h	EVT n°66
350Eh	EVT n°15	3528h	EVT n°41	3542h	EVT n°67
350Fh	EVT n°16	3529h	EVT n°42	3543h	EVT n°68
3510h	EVT n°17	352Ah	EVT n°43	3544h	EVT n°69
3511h	EVT n°18	352Bh	EVT n°44	3545h	EVT n°70
3512h	EVT n°19	352Ch	EVT n°45	3546h	EVT n°71
3513h	EVT n°20	352Dh	EVT n°46	3547h	EVT n°72
3514h	EVT n°21	352Eh	EVT n°47	3548h	EVT n°73
3515h	EVT n°22	352Fh	EVT n°48	3549h	EVT n°74
3516h	EVT n°23	3530h	EVT n°49	354Ah	EVT n°75
3517h	EVT n°24	3531h	EVT n°50	354Bh~35F9h	EVT n°76~n°250
3518h	EVT n°25	3532h	EVT n°51		
3519h	EVT n°26	3533h	EVT n°52		

Table 25 - Page 35h: Events Record

1.7.16

Page 36h: Oldest Event Data

Read access only.

Address	Contents
3600h	Most older event data

Table 26 - Page 36h: Oldest Event Data

1.7.17

Page 37h: 25 Last Fault Records Data

Read access only.

Address	Contents
3700h	Fault record values n°1
3701h	Fault record values n°2
3702h	Fault record values n°3
3703h	Fault record values n°4
3704h	Fault record values n°5
.....
3718h	Fault record values n°25

Table 27 - Page 37h: 25 Last Fault Records Data

Word n° 1: Fault number

Words n° 2 & 3 if data format is private:

Event date (second) number of seconds since 01/01/94

Words n° 4 & 5 if data format is private:

Event date (millisecond)

Word n° 6 if data format is private:

Fault date (season)

0= winter

1= summer

2= undefined

Words n° 5, 6, 7, 8, if data format is Inverted IEC 870-5-4 CP56Time2a:

Word n° 6 if data format is Inverted IEC 870-5-4 CP56Time2a:

Null value

Word n° 7: Active setting group during the fault (1 or 2)

Word n° 8: Fault origin

0= none

1= phase A

2= phase B

3= phase C

4= phases A-B

5= phases A-C

6= phases B-C

7= phases A-B-C

8= earth

Word n° 9: Fault recording starting origin

0 = NULL DEF

1 = DEF_PHASE_A

2 = DEF_PHASE_B

3 = DEF_PHASE_C

4 = DEF_TERRE

5 = DEF_DISJ_STADE1

6 = DEF_DISJ_STADE2

7 = DEF_DEAD_ZONE

8 = DEF_POLE_DISCREPANCY

9 = DEF_TAUX1

10 = DEF_TAUX2

11 = DEF_PHASE_NON_I

12 = DEF_EARTH_NON_I
 13 = DEF_NEG_NON_I
 14 = DEF_NEG_STAGE1
 15 = DEF_NON_I_STAGE1
 16 = DEF_CB_UNH_STG1
 17 = DEF_CB_UNH_STG2
 18 = DEF_NON_I_STAGE2
 Word n° 10 & 11: Fault Value Current
 Word n° 12: Phase A Current
 Word n° 13: Phase B Current
 Word n° 14: Phase C Current
 Word n° 15: Earth Current Value
 Word n° 16: Fault Acknowledgement Status:
 Non -Acknowledged = 0
 Ackn owledged = 1

1.7.18

Pages 38h to 3Ch: Selection of the Disturbance Record and Channel

Read access only.

Address	Disturbance record number	Channel
3800h	1	IA
3801h	1	IB
3802h	1	IC
3803h	1	I _E
3804h	1	Frequency
3805h	1	Logic input and outputs
3900h	2	IA
3901h	2	IB
3902h	2	IC
3903h	2	I _E
3904h	2	Frequency
3905h	2	Logic input and outputs
3A00h	3	IA
3A01h	3	IB
3A02h	3	IC
3A03h	3	I _E
3A04h	3	Frequency
3A05h	3	Logic input and outputs
3B00h	4	IA
3B01h	4	IB
3B02h	4	IC
3B03h	4	I _E
3B04h	4	Frequency
3B05h	4	Logic input and outputs
3C00h	5	IA
3C01h	5	IB

Address	Disturbance record number	Channel
3C02h	5	IC
3C03h	5	I _E
3C04h	5	Frequency
3C05h	5	Logic input and outputs

Table 28 - Pages 38h to 3Ch: Selection of the Disturbance Record and Channel

- Word n° 1: Number of samples included in the mapping
 Word n° 2: Sample number in pre-time
 Word n° 3: Sample number in post-time
 Word n° 4: Phase primary CT ratio
 Word n° 5: Phase secondary CT ratio
 Word n° 6: Earth primary CT ratio
 Word n° 7: Earth secondary CT ratio
 Word n° 8: Phase internal CT ratio
 Word n° 9: Earth internal CT ratio
 Word n° 10: Mapping last page number
 Word n° 11: Number of words in the mapping last page
 Word n° 12: Coefficient of samples conversion (=1) (Optional)
 Word n° 13: Reference of samples conversion (=1) (Optional)

1.7.19

Page 3Dh: Number of Disturbance Records Available

Read access only.

Address	Contents
3D00h	Number of disturbance records available

Table 29 - Page 3Dh: Number of Disturbance Records Available

- Word n° 1: Number of disturbance records available
 Word n° 2: Oldest disturbance record number (n)
 Words n° 3 & 4: Oldest disturbance record date (second)
 Words n° 5 & 6: Oldest disturbance record date (millisecond)
 Word n° 7: Disturbance record starting origin
 1= trip relay (RL1)
 2= instantaneous threshold
 3= remote command
 4= logic input
 Word n° 8: Acknowledge
 Word n° 9: Number of Previous Disturbance record (n+1)
 Words n° 10 & 11: Previous disturbance record date (second)
 Words n° 12 & 13: Previous disturbance record date (millisecond)
 Word n° 14: Disturbance record starting origin
 1= trip relay (RL1)
 2= instantaneous threshold
 3= remote command
 4= logic input

- Word n° 15: Acknowledge
- Word n° 16: Number of Previous Disturbance record (n+2)
- Words n° 17 & 18: Previous disturbance record date (second)
- Words n° 19 & 20: Previous disturbance record date (millisecond)
- Word n° 21: Disturbance record starting origin
1= trip relay (RL1)
2= instantaneous threshold
3= remote command
4= logic input
- Word n° 22: Acknowledge
- Word n° 23: Number of Previous Disturbance record (n+3)
- Words n° 24 & 25: Previous disturbance record date (second)
- Words n° 26 & 27: Previous disturbance record date (millisecond)
- Word n° 28: Disturbance record starting origin
1= trip relay (RL1)
2= instantaneous threshold
3= remote command
4= logic input
- Word n° 29: Acknowledge
- Word n° 30: Number of Previous Disturbance record (n+4)
- Words n° 31 & 32: Previous disturbance record date (second)
- Words n° 33 & 34: Previous disturbance record date (millisecond)
- Word n° 35: Disturbance record starting origin
1= trip relay (RL1)
2= instantaneous threshold
3= remote command
4= logic input
- Word n° 36: Acknowledge

1.8 Description of Mapping Format

Code	Format Description		Format Data		Data
	Type	Description	Bit	Value	
F1	Unsigned Integer	Numerical Data: 0 - 65535	-	-	-
F2	Signed Integer	Numerical Data: -32768 - 32767	-	-	-
F3		Reserved			
F4	Unsigned Integer	Communications Speed	-	0	300
			-	1	600
			-	2	1200
			-	3	2400
			-	4	4800
			-	5	9600
			-	6	19200
			-	7	38400
F5	Unsigned Integer	Communications Parity	-	0	None
			-	1	Even
			-	2	Odd
F6	Unsigned Integer	Trip Relay Mapping (Part 1)	0	1	DTA'
			1	2	DTB'
			2	4	DTC'
			3	8	Stage 1
			4	16	Stage 2
			5	32	Dead zone
			6	64	Pole Discrepancy
			7	128	Aux. 1
			8	256	Aux. 2
			9	512	DTE'
			10	1024	Trip Phase Non I stage1
			11	2048	Trip Neg. Non I stage1
			12	4096	Trip Neg. stage1
			13	8192	Trip Non I stage1
			14	16384	Trip Unhealthy stage1
			15	32768	Trip Unhealthy stage2
F6'	Unsigned Integer	Trip Relay Mapping (Part 2)	0	1	Trip Equation A
			1	2	Trip Equation B
			2	4	Trip Equation C
			3	8	Trip Equation D
			4	16	Trip Equation E
			5	32	Trip Equation F
			6	64	Trip Equation G
			7	128	Trip Equation H
			8	256	Trip Earth Non I stage1
			9	512	Trip Non I stage2

Code	Format Description	Description	Format Data		Data
			Bit	Value	
F7		Reserved	-	-	-
F8	Unsigned Integer	Trip Relay Latching Mapping (Part 1)	0	1	DTA'
			1	2	DTB'
			2	4	DTC'
			3	8	Stage 1
			4	16	Stage 2
			5	32	Dead zone
			6	64	Pole Discrepancy
			7	128	Aux. 1
			8	256	Aux. 2
			9	512	DTE'
			10	1024	Phase Non I stage1
			11	2048	Negative Non I stage1
			12	4096	Negative stage1
			13	8192	Non I stage1
			14	16384	Unhealthy stage1
			15	32768	Unhealthy stage2
F8'	Unsigned Integer	Trip Relay Latching Mapping (Part 2)	0	1	Earth Non I stage1
			1	2	Non I stage2
F9	Unsigned Integer	Remote Control Word 1	0	1	Unlatch Trip Contact
			1	2	Acknowledge 1st Alarm
			2	4	Acknowledge All Alarms
			3	8	Reserved
			4	16	Reserved
			5	32	Change Setting Group
			6	64	Reserved
			7	128	Reserved
			8	256	Disturbance Record Remote Start
			9	512	Reserved
			10	1024	Reserved
			11	2048	Reserved
			12	4096	Manual event/fault/distur acknowledgement mode
			13	8192	Acknowledge Oldest Event Record
			14	16384	Acknowledge Oldest Fault Record
			15	32768	Acknowledge Hardware SRAM Alarm
F10		ASCII Characters	-	32 - 127	ASCII Character 1
			-	32 - 127	ASCII Character 2
F10'		ASCII Characters	-	32 - 127	ASCII Character 1
				32 - 127	ASCII Character 2
				32 - 127	ASCII Character 3
				32 - 127	ASCII Character 4
				32 - 127	ASCII Character 5
				32 - 127	ASCII Character 6

Code	Format Description	Description	Format Data		Data
			Bit	Value	
				32 - 127	ASCII Character 7
				32 - 127	ASCII Character 8
F11		Reserved	-	-	-
F12	Unsigned Integer	Logic Inputs	0	1	Logic Input Number 1
			1	2	Logic Input Number 2
			2	4	Logic Input Number 3
			3	8	Logic Input Number 4
			4	16	Logic Input Number 5
F13	Unsigned Integer	Output Contacts status	0	1	Output Contact RL1 (Trip)
			1	2	Output Contact RL2
			2	4	Output Contact RL3
			3	8	Output Contact RL4
			4	16	Output Contact RL0 (Watchdog)
			5	32	Output Contact RL5
			6	64	Output Contact RL6
			7	128	Output Contact RL7
			8	256	Output Contact RL8
F14	Unsigned Integer	Output Contact Mapping	0	1	Output Contact RL2
			1	2	Output Contact RL3
			2	4	Output Contact RL4
			3	8	Output Contact RL5
			4	16	Output Contact RL6
			5	32	Output Contact RL7
			6	64	Output Contact RL8
F15	Unsigned Integer	Logic Input Mapping(word 1)	0	1	Trip phase A
			1	2	Trip phase B
			2	4	Trip phase C
			3	8	Trip 3 phase
			4	16	Relay unlatch
			5	32	52a
			6	64	52b
			7	128	tAux1
			8	256	tAux2
			9	512	Change Setting group
			10	1024	Disturbance recorder external start
			11	2048	Secu. 1
			12	4096	Secu. 2
			13	8192	LEDs reset
			14	16384	CB unhealthy
			15	32768	Block Logic 1
F15'	Unsigned Integer	Logic Input Mapping(word 2)	0	1	Block Logic 2
			1	2	SYNCHRO
			2	4	External Non I Trip order

Code	Format Description		Format Data		Data
	Type	Description	Bit	Value	
F16		Reserved			
F17	Unsigned Integer	Internal logic data	0	1	Latching
			1	2	Trip
F18	Signed Long Integer	Numerical Data : -2147483648 to 2147483647	-	-	-
F19	Unsigned Integer	User Configurable LED Mapping (Part 1)	0	1	External DTA
			1	2	External DTB
			2	4	External DTC
			3	8	External DTRI
			4	16	Backup DTA'
			5	32	Backup DTB'
			6	64	Backup DTC'
			7	128	t Stage 1
			8	256	t Stage 2
			9	512	Problem secu 1
			10	1024	Problem secu 2
			11	2048	t_DZ
			12	4096	tPD
			13	8192	tAux1
			14	16384	tAux2
			15	32768	Backup DTE'
F19'	Unsigned Integer	User Configurable LED Mapping (Part 2)	0	1	CB Open time ext.
			1	2	CB operation Nb
			2	4	Sum A n
			3	8	CB Open time st.1
			4	16	Earth Non I stage1
			5	32	Negative Non I stage1
			6	64	Retrip order negative
			7	128	Non I general retrip
			8	256	CB Unhealthy stage1
			9	512	CB Unhealthy stage2
			10	1024	Logic Equation A
			11	2048	Logic Equation B
			12	4096	Logic Equation C
			13	8192	Logic Equation D
			14	16384	Logic Equation E
			15	32768	Logic Equation F
F19"	Unsigned Integer	User Configurable LED Mapping (Part 3)	0	1	Logic Equation G
			1	2	Logic Equation H
			2	4	Phase.Non I Stage1
			3	8	Non I general back-up

Code	Format Description		Format Data		Data
	Type	Description	Bit	Value	
F20	Unsigned Integer	Logic Input Data Status	0	1	External trip order phase A
			1	2	External trip order phase B
			2	4	External trip order phase C
			3	8	External trip order 3 phase
			4	16	Relay Unlatch
			5	32	52a
			6	64	52b
			7	128	tAux1
			8	256	tAux2
			9	512	Change Setting group
			10	1024	Disturbance record Start
			11	2048	Secu. 1
			12	4096	Secu. 2
			13	8192	LEDs reset
			14	16384	CB Unhealthy
	15	32768	Block Logic 1		
F20'	Unsigned Integer	Logic Input Data Status	0	1	Block Logic 2
			1	2	GPS time synchro
			2	4	External non I input
			3	8	Reserved
F21	Unsigned Integer	Software Version	-	10	Version 1.A
			-	11	Version 1.B
			-	20	Version2.A etc...
F22	Unsigned Integer	Disturbance record start kinds	0	1	Disturbance record starts on Ins.
			1	2	Disturbance record starts on Trip
F23	Unsigned Integer	Quick Read Status Byte Format	0	1	Major Hardware Alarm Present
			1	2	Minor Hardware Alarm Present
			2	4	Non-Acknowledged Event Available
			3	8	Time Synchronisation State
			4	16	Non-Acknowledged Disturbance Record Available
			5	32	Non-Acknowledged Fault Record Available
F24	Unsigned Integer	Breaker failure functionality	-	0	Disabled/No
			-	1	Enabled/Yes
F25	Characters ASCII				
F26	Unsigned Integer	Default Display Selection	-	1	IA RMS Measurement
			-	2	IB RMS Measurement
			-	3	IC RMS Measurement
			-	4	IN RMS Measurement
			-	5	IA, IB, IC, IN RMS Measurements
F27	Unsigned Integer	1st stage reset configuration	-	0	Disabled/No
			-	1	Enabled/Yes
F28	Unsigned Integer	Communications data Bits	0	1	7 bit data
			1	2	8 bit datas

Code	Format Description		Format Data		Data
	Type	Description	Bit	Value	
F29	Unsigned Integer	Communications Stop Bits	-	0	1 Stop Bit
			-	1	2 Stop Bits
F30	Unsigned Integer	Rear communication Availability	0	1	Communications Disabled
			1	2	Communications Enabled
F31	Unsigned Integer	50 BF flag	0	1	1st stage delayed Breaker failure data
			1	2	2nd stage delayed Breaker failure data
			2	4	Configuration problem
			3	8	Non I stage 1
			4	16	Non I stage 2
			5	32	CB Unhealthy stage1
			6	64	CB Unhealthy stage2
			7	128	Phase configuration problem
			8	256	Earth configuration problem
			9	512	Negative configuration problem
			F32	Unsigned Integer	Security flag
1	2	Security problem2			
2	4	EL configured on Secu1			
3	8	EL configured on Secu2			
4	16	Security Configuration problem			
F33	Unsigned Integer	Phase current & 50 BF flag	0	1	Indicates the current presence
			1	2	Instant information for current presence
			2	4	Stage 1 information for current presence
			3	8	Indicates the first detection of current presence
F34	Unsigned Integer	CB position	0	1	Wrong configuration of Breaker position
			1	2	Wrong Breaker position
			2	4	CB on Open Position
					Reserved
F35	Unsigned Integer	End fault function data status	0	1	Instantaneous data DZ
			1	2	Delayed data T_DZ
			2	4	DZ Configuration problem
			3	8	Phase A threshold crossed
			4	16	Phase B threshold crossed
			5	32	Phase C threshold crossed
F36	Unsigned Integer	Pole discrepancy function data status	0	1	Instantaneous data PD
			1	2	Delayed data T_PD
			2	4	PD Configuration problem
			3	8	Phase A threshold crossed
			4	16	Phase B threshold crossed
			5	32	Phase C threshold crossed
F37	Unsigned Integer	End fault protection memorisation	0	1	Instantaneous data DZ
			1	2	Delayed data T_DZ

Code	Format Description		Format Data		Data
	Type	Description	Bit	Value	
F38	Unsigned Integer	Pole discrepancy function memorisation	0	1	Instantaneous data PD
			1	2	Delayed data T_PD
F39		Reserved			
F40	Unsigned Integer	Aux. data Memorisation	0	1	Aux1
			1	2	Aux2
F41		Communications Port Allocation	-	0	Front and Rear Port ModBus Communications
			-	1	Front Port ModBus and Rear Port Courier Communications
			-	2	Front Port ModBus and Rear Port VDEW Communications
F42	Unsigned Integer	End Fault protection function	0	1	Disabled
			1	2	Enabled
F43	Unsigned Integer	Pole discrepancy function	0	1	Disabled
			1	2	Enabled
F44	Unsigned Integer	Breaker supervision function	0	1	Disabled
			1	2	Enabled
F45	Unsigned Integer	Hardware Alarm Status	0	1	Watchdog
			1	2	User Communications Failure
			2	4	SETTING Failure
			3	8	ANA Failure
			4	16	Real Time Clock Failure
			5	32	EEPROM Failure
			6	64	SRAM Failure
			7	128	DEFAULT SETTING
			8	256	Main Power Supply
			9	512	Auxiliary Power Supplies
			10	1024	Transformers Offset Failure
F46	Unsigned Integer	50 BF supervision flag	0	1	Breaker longest operating time elapsed on external order
			1	2	Breaker longest operating time elapsed on 1st stage order
			2	4	Maximum number of breaker operation reached
			3	8	CB SA2N elapsed
F47	Unsigned Integer	Configuration group change	-	0	change on Input edge or remote order or via front panel
			-	1	change on Input level change
F48	Unsigned integer	Modbus Date Format Configuration		0	Private
				1	IEC
F49	Unsigned Integer	Fault number to be displayed	-	0	None
			-	1~25	1~25
F50	Unsigned Integer	Opto Power Supply Configuration	-	0	DC Supply
			-	1	AC Supply
F51	Unsigned Integer	Remote Control Word 2	0	1	Unlatch trip relaly
			1	2	Unlatch output relay
			2	4	Reserved
			3	8	Reset SA2n
			4	16	Reset CB Open Number

Code	Format Description		Format Data		Data
	Type	Description	Bit	Value	
			5	32	Reset event number
					Reserved
F52	Unsigned Integer	Wiring check function	-	0	Disable
			-	1	Enable
F53	Unsigned Integer	Relay to test	0	1	Relay 1 (Trip)
			1	2	Relay 2
			2	4	Relay 3
			3	8	Relay 4(watch dog)
			4	16	Relay 5
			5	32	Relay 6
			6	64	Relay 7
			7	128	Relay 8
F54	Unsigned Integer	Aux. Input Data	0	1	Disable
			1	2	Enable
F55	Unsigned Integer	Number of disturbance records	-	0	None
			-	1	1
			-	2	2
			-	3	3
			-	4	4
			-	5	5
F56	Unsigned Integer	Breaker fail phase function	-	0	Disable
			-	1	Enable
F57	Unsigned Integer	Breaker fail earth function	-	0	Disable
			-	1	Enable
F58	Unsigned Integer	Boolean Equation Operand		0	None
				1	Ph. A Stage 1
				2	Ph. B Stage 1
				3	Ph. C Stage 1
				4	Earth Non I stage1
				5	Earth Stage 1
				6	Neg. Non I stage1
				7	Neg. Stage 1
				8	Phase.Non I Stage1
				9	CB unhealthy stage 1
				10	CB unhealthy stage 2
				11	t Stage 1
				12	t Stage 2
				13	t dead Zone
				14	t Pole Discre.
				15	t Aux1
				16	t Aux2
				17	CB open ext.
				18	CB open st. 1

Code	Format Description	Description	Format Data		Data
			Bit	Value	
				19	CB NB. op.
				20	Sum A n
				21	Input 1
				22	Input 2
				23	Input 3
				24	Input 4
				25	Input 5
				26	Non I stage1
				27	Non I stage2
F59	Unsigned Integer	Boolean Equation Operator		0	OR
				1	OR NOT
				2	AND
				3	AND NOT
F61	Unsigned Integer	Logic Equation Flag	0	1	Equation A
			1	2	Equation B
			2	4	Equation C
			3	8	Equation D
			4	16	Equation E
			5	32	Equation F
			6	64	Equation G
			7	128	Equation H
F62	Unsigned Integer	External Non I Reset by		0	Reset by current/Default
				1	Reset by CB open
				2	Reset by current & CB open
F63	Unsigned Integer	Remote Control Word 3	0	1	Reserved
			1	2	Reserved
			2	4	Acknowledge Oldest Disturbance Record
			3	8	Reserved
			4	16	Reserved
			5	32	Reserved
			6	64	Reserved
			7	128	Reserved
			8	256	Reserved
			9	512	Reserved
			10	1024	Reserved
			11	2048	Reserved
			12	4096	Reserved
			13	8192	Reserved
			14	16384	Erase all records (events, faults, alarms, disturbances,etc)
			15	32768	Reserved
F65	Unsigned Integer	Memo alarm flag 1	0	1	Phase Non I stage1
			1	2	Earth Non I stage1
			2	4	Negative Non I stage1

Code	Format Description	Description	Format Data		Data
			Bit	Value	
			3	8	Negative stage1
			4	16	Equation A
			5	32	Equation B
			6	64	Equation C
			7	128	Equation D
			8	256	Equation E
			9	512	Equation F
			10	1024	Equation G
			11	2048	Equation H
F66	Unsigned Integer	Blocking Logic Mapping	0	1	CBF phase
			1	2	CBF earth
			2	4	CBF neg.
			3	8	Dead zone
			4	16	Pole discrepancy
			5	32	tAux1
			6	64	tAux2
F98	Unsigned Integer	auxiliary power supply self test status	0	1	-3V3 out of range
			1	2	5V0 out of range
			2	4	3V3 out of range
			3	8	12V out of range
			4	16	1V3 out of range
			5	32	0V out of range
F99	Unsigned Integer	Transformer self test status	0	1	Abnormal offset with transformer 1
			1	2	Abnormal offset with transformer 2
			2	4	Abnormal offset with transformer 3
			3	8	Abnormal offset with transformer 4
			4	16	Abnormal offset with transformer 5
			5	32	Abnormal offset with transformer 6
			6	64	Abnormal offset with transformer 7
			7	128	Abnormal offset with transformer 8
			8	256	Abnormal offset with transformer 9

Table 30 - Description of Mapping Format

2 K-BUS PROTOCOL AND COURIER LANGUAGE

The serial communications are transmitted on K-Bus, a multi-drop network proposing an instantaneous interface with the IEC 870-5 FT1.2 standards. The language and the communication protocol used are Courier. This concept permits especially to the generic programs of the principal units to access to a high number of different relays without need to change permanently the principal unit program for each relay type. The relays form a distributed database in which the principal workstation proceeds to a selective call of the slave relays in order to know all necessary information.

Courier is designed to work using a selective call feature which forbids any slave periphery to communicate directly with the central unit when a particular information about an event needs to be transmitted. The slave workstation has to wait that the principal workstation asks for the information. With Courier protocol, each information is given into a box with a code of the length and the database type. By knowing the database format, the reception periphery can read them.

2.1 K-BUS

K-Bus is a communication system developed for connecting the slave peripheries to the central unit, permitting them to execute all remote monitoring and remote control functions using the appropriate communication language. K-Bus is not able to permit a direct communication between the slave peripheries. Only a communication between the central unit and the slave peripheries can be established. The principal characteristics of the K-Bus are the profitability, high security level, his installation facility and his user friendliness.

2.1.1 K-Bus Transmission Layer

The communication port RS485 is based on several levels of reception and transmission voltages with galvanic isolation given by a transformer. A selective call protocol is used. No relay unit is allowed to transmit before having received a validation message without any error detection. The transmission is synchronous on a pair of isolated waves. The data are coded FM0 with a clock signal to eliminate all CC-component, allowing the signal to cross the transformers.

With the exception of the central units, each network node is passive. The defective units can not interfere with the communication established with the other healthy units. The message format is HDLC. The data transmission speed is 64 Kbits/s.

2.1.2 K-Bus Connection

The connection on the K-Bus port is realized by screwed terminals of 4 mm of MIDOS standards or by FASTON-connectors. A cabled pair is sufficient to realize the connection, Knowing that the polarity is not important. It is recommended to use an external screen earth linked at the end of the principal workstation only. The screen has to be fixed with a M4 screw following the wiring scheme. The functioning of the K-BUS network is guaranteed for 32 units connected on 1000 meters of cables. Thanks to the data code method, the polarity of the Bus cable connection is not important.

Note The K-Bus network has to finish with a 150 ohms resistance on each end of the bus. The principal workstation can be placed anywhere on the network. This command point has to be unique.

2.1.3 Auxiliary Equipment

For communication with the relay it is necessary to have at least one converter case K-Bus/IEC870-5 of the type KITZ and a computer suitable software, an interconnection cable RS232 for connecting the KITZ to the computer and a software conform to the specification of the Courier protocol.

2.2 Relay Courier Database

The Courier database is two dimensional structure with each cell in a database being referenced by a row and a column address. Both the column and the row can take a range from 0 to 255. Addresses in the database are specified as hexadecimal values, eg 0A02 is column 0A (10 decimal) row 02. Associated settings /data will be part of the same column, row zero of the column contains a text string to identify the contents of the column.

This database is given in Appendix 1.

2.2.1 List of Events Generated by the Relay

Code	Event text	Description	Associated COURIER cell
0001	SET. CHANGE	Setting parameter Change	
0002	DIST TRIG	Disturbance Recorder Trip	
0003	UNLATCH TRIP	Unlock Trip TC	0021
0004	Ph. A Stage 1	Ph. A Stage 1 Start	0023
0005	Ph. B Stage 1	Ph. B Stage 1 Start	0023
0006	Ph. C Stage 1	Ph. C Stage 1 Start	0023
0007	PD	Pole Discrepancy Start	0023
0008	DZ>	Dead Zone Start	0023
0009	tPh. A Stage 1	Ph. A Stage 1 Trip	0023
0010	tPh. B Stage 1	Ph. B Stage 1 Trip	0023
0011	tPh. C Stage 1	Ph. C Stage 1 Trip	0023
0012	t Stage 1	Stage 1 Trip	0023
0013	t Stage 2	Stage 2 Trip	0023
0014	t PD	Pole Discrepancy Trip	0023
0015	t DZ>	Dead Zone Trip	0023
0016	t Aux1	Auxiliary input 1 Trip	0023
0017	t Aux2	Auxiliary input 2 Trip	0023
0018	CB Open time ext.	External CB open time Trip	0024
0019	CB Open time st. 1	CB open time stage 1 Trip	0024
0020	CB Operation Nb	CB operation number Trip	0024
0021	SA2n	SA2n Trip	0024
0022	Setting Pb. tStage 1	Setting problem with Stage 1 Trip	0024
0023	Setting Pb. DZ	Setting problem with Dead Zone Trip	0024
0024	Setting Pb. PD	Setting problem with Pole Discrepancy Trip	0024
0025	Secu. Setting Pb.	Setting problem with relay security	0024
0026	Security 1 Pb.	Problem with security relay 1	0024
0027	Security 1 Pb.	Problem with security relay 2	0024

Code	Event text	Description	Associated COURIER cell
0028	Security 1 Input	Security 1 input	0020
0029	Security 2 Input	Security 2 input	0020
0030	Trip Ph. A ext.	Ph. A external Trip	0023
0031	Trip Ph. B ext.	Ph. B external Trip	0023
0032	Trip Ph. C ext.	Ph. C external Trip	0023
0033	Trip 3Ph. Ext.	3 Phase external Trip	0023
0034	52 A	CB Position Closed (O/O)	0024
0035	52 B	CB Position open (F/O)	0024
0036	TS Change	Logical input change	0020
0037	Aux. relays	Auxiliary relays change	0021
0038	Unlatch Aux. Rel.	Auxiliary relays unlatched	-
0039	Latched Relay TRIP	Trip relay unlatched	-
0040	Latched Aux. Rel.	Auxiliary relays latched	-
0041	Set. Grp change	Setting group change	-
0042	Ack 1 Al (FAV)	1st alarm acknowledge (Front panel)	0022
0043	Ack Alar (FAV)	All alarms acknowledge (Front panel)	0022
0044	Ack 1 Al (COM)	1st alarm acknowledge (Comm.)	0022
0045	Ack Alar	All alarms acknowledge (Comm. or input)	0022
0046	Hard Maj Alarm	Hardware major alarm	0022
0047	Hard Min Alarm	Hardware minor alarm	0022
0048	TRIP tPh. A Stage 1	Ph. A Stage 1 Trip (Relay command)	-
0049	TRIP tPh. B Stage 1	Ph. B Stage 1 Trip (Relay command)	-
0050	TRIP tPh. C Stage 1	Ph. C Stage 1 Trip (Relay command)	-
0051	TRIP t Stage 1	Stage 1 Trip (Relay command)	-
0052	TRIP t Stage 2	Stage 2 Trip (Relay command)	-
0053	TRIP t DZ>	Dead Zone Trip (Relay command)	-
0054	TRIP t PD	Pole Discrepancy Trip (Relay command)	-
0055	TRIP t Aux1	Auxiliary input 1 Trip (Relay command)	-
0056	TRIP t Aux2	Auxiliary input 2 Trip (Relay command)	-
0057	Earth Stage 1	Earth stage 1 Start	0024
0058	t Earth Stage 1	Earth stage 1 Trip	0024
0059	TRIP t Earth Stage 1	Earth stage 1 Trip (Relay command)	-
0060	Block logic 1		0025
0061	Block logic 2		0025
0062	External Non I trip		0025
0063	Negative inst		0025
0064	Negative stage1		0025
0065	Phase non I inst		0025
0066	Phase non I stage1		0025
0067	Earth Non I inst		0025
0068	Earth Non I stage1		0025
0069	Negative Non I stage1		0025
0070	Non I stage1		0025
0071	Non I stage2		0025

Code	Event text	Description	Associated COURIER cell
0072	CB unhealth stage1		0025
0073	CB unhealth stage2		0025
0074	Equation A		0026
0075	Equation B		0026
0076	Equation C		0026
0077	Equation D		0026
0078	Equation E		0026
0079	Equation F		0026
0080	Equation G		0026
0081	Equation H		0026

Note *When the cell reference is different from 0, this means that an event is generated the event takes place and another event is generated when the event disappears.*

Table 31 - List of Events generated by the Relay

When the cell reference is equal to zero, only the event is generated.

Twelve bits are available in the character String to describe the content of a Courier cell.

When the event appears, the corresponding bit of the associated format changes to "1".

When the event disappears, the corresponding bit of the associated format changes to "0".

2.3

Setting Changes

This uses a combination of three commands to perform a settings change:

Enter Setting Mode Checks that the cell is settable and returns to the limits.

Pre-load Setting Place a new value in the cell, this value is echoed to ensure that no setting changes has taken place, the confirmation of the new setting value does not achieved by this action.

Execute Setting Confirms the setting change, if the change is valid then a positive response will be returned, if the setting change fails then an error response will be returned.

Abort Setting This command can be used to abandon the setting change.

This is the most secure method and is ideally suited to on-line editors as the setting limits are taken from the relay before the setting change is made. However this method can be slow if many settings are being changed as three commands are required for each change.

2.4 Systems Integration Data

2.4.1 Address of the Relay

The relays can have any address between 1 and 254 included. The address 255 corresponds to the global address to which all relays and all the other slave peripheries respond. The Courier protocol specifies that no response can be resent from the slave periphery to the global message. This permits to avoid that all peripheries respond at the same time creating by this way a conflict on the bus.

Each relay possesses an address settled on 225 in order to guarantee that in case of his connection to the operating network, his address cannot create any conflict with the address of another periphery already in exploitation. In order to permit to a new periphery to be entirely operational, his address has to be settled. The address can be modified manually in capturing the password, than in following the method of the setting change through the user interface on the front plate of the relay.

Similarly, if the computerized system used takes in charge the auto addressing, the relay address can be settled on 0 by activating the auto-addressing characteristics of the computer software. The relay receives then the next valid address on the bus.

If the address is 255 or not known, it can be modified by sending a new address, with a global message, to a periphery possessing a particular serial number. This method is used for those peripheries which do not have any user interface for reading or changing the address in process.

2.4.2 Measured Values

Each measured value can be periodically extracted by a selective call of P821 relay.

2.4.3 Status Word

Each response of a slave periphery contains an octet of status. This octet is resent by the relay at the beginning of each message for signaling important data. The principal workstation can be designed to respond automatically to these important data.

The contained indications are the following:

- Bit 0: 1=Recording of disturbance available for retrieval
- Bit 1: 1=Change of the unit status word
- Bit 2: 1=Change of the control status word
- Bit 3: 1=Relay busy, no response possible in time
- Bit 4: 1=Relay out of service
- Bit 5: 1=Recording of events available for retrieval
- Bit 6: 1=Switched Alarm indicator
- Bit 7: 1=Switched tripping indicator

2.4.4 Unit Status Word

The unit status word is located in the menu 000C

Each bits pair of the unit status word serves to indicate the status (position) of the unit elements checked through the relay.

This functionality is not supported on the MiCOM P821 relay.

2.4.5 Control Status Word

The control status word is located in the cell of the menu 000D

It is used for transmitting the control information of the slave periphery to the central unit. Nevertheless, the relays described in this manual are protection relays, which do not use this control characteristic.

2.4.6 Logic Input Status Word

The logic input status can be observed in proceeding to a selective call from the cell of menu 0020. The 2 bits inferior of the returned value indicating the status of each of the 2 logic inputs. This cell is accessible only in reading.

- Bit 0: Logic Input 1
- Bit 1: Logic Input 2
- Bit 2: Logic Input 3
- Bit 3: Logic Input 4
- Bit 4: Logic Input 5

2.4.7 Output Relay Status Word

The output relay status can be observed in proceeding to a selective call from the cell of menu 0021. The 8 bits inferior to the returned value indicating the status of each of the seven output relays. This cell is accessible only in reading.

- Bit 0: Relay 1 (TRIP)
- Bit 1,2,3: Programmable relays n° 2,3,4,
- Bit 4: Watchdog
- Bit 5,6,7,8: Programmable relays n° 5,6,7,8

2.4.8 Alarm Information

The status of internal controls triggered by the auto-control program of the relays can be observed in proceeding to a selective call of the cell of menu 0022.

The bits 0 to 10 indicate the material controls of the product.

- Bit 0 Analog Output Error
- Bit 1 Communication Error
- Bit 2 EEPROM Data error
- Bit 3 CT Error
- Bit 4 Clock Error
- Bit 5 EEPROM Calibration error
- Bit 6 RAM Error
- Bit 7 Default settings
- Bit 8 Main Power Supply
- Bit 9 Auxiliary Power Supplies
- Bit 10 Transformers Offset Failure

2.4.9

Protection Indication

The protection indications provide the status of different protection elements in the relay; and thus the fault indications are so generated. In case of a fault recording, these indications are transmitted to an events recorder. This is the only way to access to these indications.

The status of the internal protection indication of the relays can be observed in proceeding to a selective call of the cell of menu 0023 , and 0024.

Table 32 and Table 33 show the list of the protection indications of the cell 0023 & 0024

Bit Position	Protection Function
0	Ph. A Stage 1
1	Ph. B Stage 1
2	Ph. C Stage 1
3	Dead Zone
4	Pole Discrepancy
5	t Ph. A Stage 1
6	t Ph. B Stage 1
7	t Ph. C Stage 1
8	t Dead Zone
9	t Pole Discrepancy
10	t Stage 1
11	t Stage 2
12	Ph. A Ext.
13	Ph. B Ext.
14	Ph. C Ext.
15	3Ph. Ext.

Table 32 - Protection Indications of the cell 0023

Bit Position	Protection Function
0	t Aux1
1	t Aux2
2	CB Open time ext.
3	CB Open time stage 1
4	CB operation number
5	SA2n
6	Setting Pb. tStage 1
7	Setting Pb. DZ
8	Setting Pb. PD
9	Security Setting Pb.
10	Security 1 Pb.
11	Security 2 Pb.
12	Earth Stage 1
13	t Earth Stage 1
14	52A (CB position "closed")
15	52B (CB position "open")

Table 33 - Protection Indications of the cell 0024

2.4.10 Control and Supervision

The control functions through the relays can be executed using a serial link. These functions particularly constitute the changes of an individual relay setting parameters, the changes of the setting group, the remote control of the circuit breaker, as well as the functions and the locking of the selected output relays.

The remote control is limited to the selected control functions in Table 34 of the relay menu. In order to modify this selection, a corresponding password is needed. The CRC and the controls of the message length are used every time a message is received. No response is given for message received with an error detection. The principle unit can be re-initialized in order to send again an order, as often as it seems necessary, if it does not receive any response or have received a response with an error detection.

<i>Note</i>	<i>The control commands are generally materialized by the change of the cell value. They dispose the same inherent security. No response is allowed for the global orders to avoid any conflict in the bus. For this type of order, a double transmission is used by the relay for the verification of the message. The relay transmits then a confirmation indicating that the control order or the change of setting is accepted. If this is not the case, the relay sends an error message.</i>
-------------	----------------------------------------------------------------------------------------------------------------------------------------------------------------------------------------------------------------------------------------------------------------------------------------------------------------------------------------------------------------------------------------------------------------------------------------------------------------------------------------------------

2.4.11 Remote Change of Setting

When using the serial port, the relay responds to the orders of setting changes only if the SD0 Link =1 is selected.

- The selection of the SD0 Link =1 blocks all the remote changes of settings with the exception of the SC logical Links and the password capture.
- When the SD0 Link =0 is selected, the remote setting changes are protected by the password.

To make a remote changes of settings, a password is needed to be captured (remotely), and then the SD and SD0 function Links have to be set equal to 1.

2.5 Events Extraction

Events can be extracted either manually or automatically. For automatic extraction all events are extracted in sequential order using the standard Courier mechanism, this includes Faults. The manual approach allows the user to select events and faults randomly from the stored records.

2.5.1 Automatic Event Extraction

This method is intended for continuous extraction of events and fault information as it is produced via the rear port.

When a new event information is created, the event bit is set within the status byte. This indicates to the Master device that an event information is available. The oldest (and not extracted) event can be extracted from the relay using the Send Event Command. The relay will respond with the event data, which will be either a Courier Type 0 or Type 3 event. The latest type is used for the fault records.

Once an event is extracted from the relay, the Accept Event can be used to confirm that this event has been successfully extracted. If all the events are extracted, then the event bit will reset. If there are more events to be extracted, the next one can be accessed using the Send Event Command as before.

2.5.2 Events Types

Events will be created by the relay under these circumstances:

- Change of state of output contact
- Change of state of opto input
- Protection element operation
- Alarm condition
- Setting change
- Fault record (Type 3 Courier Event)

2.5.3 Event Format

The Send Event Command results in the return of these fields by the relay:

- Cell Reference
- Time stamp
- Cell text
- Cell value

Table 31 shows how the content of the above mentioned fields are interpreted. The fault event will return a Courier Type 3 event which contains the above fields together with two additional fields:

- Event extraction column
- Event number

These fields contain additional information which are extracted from the relay using the referenced extraction column. Row 01 of the extraction column contains a setting which allows the selection of the fault record. This setting should be set to the event number value returned within the record, the extended data can be extracted from the relay by uploading the text and data from the column.

2.5.4 Manual Record Extraction

Column 02 of the database can be used to manually view the fault records. The contents of this column will depend of the nature of the record selected. It is possible to select directly a fault record.

Fault record selection (Row 01) – this cell can be used to directly select a fault record using a value between 0 and 4 to select one of the five stored fault records (0 will be the most recent fault while 4 is the oldest one). The column will then contain the details of the fault record selected (Row 02 to 0A).

<i>Note</i>	<i>If this column is used to extract event information from the relay, the number associated with a particular record will change when a new fault occurs.</i>
-------------	----------------------------------------------------------------------------------------------------------------------------------------------------------------

2.6 Disturbance Record Extraction

The stored disturbance records within the relay are accessible via the Courier interface.

Select Record Number (Row 01) – this cell can be used to select the record to be extracted. Record 0 will be the oldest un-extracted record, older records will be assigned positive values, and negative values will be used for more recent records. To facilitate automatic extraction via the rear port, the disturbance bit of the Status byte is set by the relay whenever there are un-extracted disturbance records.

Once a record has been selected, using the above cell, the time and date of the record can be read from the cell 02. The disturbance record itself can be extracted using the block transfer mechanism from cell B00B.

As it has been stated, the rear Courier port can be used to automatically extract disturbance records as they occur. This is possible when using the standard Courier mechanism defined in chapter 8 of the Courier User Guide.

2.7 Appendix 1

Col	Row	Menu Text	Data Type	Ind	Values (*: default)	Depend	Cell Type	Min/Max/Step
00	00	SYSTEM DATA						
	01	Language	Ver>: Indexed String	0 1 2 3	Lang1 (French) Lang2 (English) * Lang3 (German) Lang4 (Spanish)		Setting	0/3/1
	02	Password	ASCII Password(4 bytes)		AAAA		Setting	32/127/1
	03	Fnlinks: NON IMPLEMENTE						
	04	Description	ASCII Text (6 bytes)		"P922xy" or "P821 xy", with: x = S or – y = 0 or 1 (V. Gam)		Setting	32/127/1
	05	Plant Reference	ASCII Text (4 bytes)		"Pref"		Setting	32/127/1
	06	Model Number	ASCII Text (16 bytes)		"Model Number"		Data	
	07	Firmware Number: NON IMPLEMENTE						
	08	Serial Number	ASCII Text (16 bytes)		"Serial Number"		Data	
	09	Frequency	Unsigned Integer (2 bytes)		XXXX Hz		Setting	50/60/10
	0A	Communication Level	Unsigned Integer (2 bytes)		1		Data	
	0B	Address	Unsigned Integer (2 bytes)		1*		Setting	1/255/1
	0C	Plant Status Word: NON IMPLEMENTE						
	0D	Control Status Word: NON IMPLEMENTE						
	0E	Setting Group	Unsigned Integer				Data	
	0F	Load shed Stage: NON IMPLEMENTE						
	10	Circuit Breaker Control	NON IMPLEMENTE					
	11	Software Reference	ASCII Text (16 characters)		V10.A		Data	
	12-1F	Unused, reserved						
	20	Logic Input Status	Binary flag (5 bits / 2 bits)		0: log input 1 1: log input 2 2: log input 3 3: log input 4 4: log input 5		Data	
	21	Relay Output Status	Binary flag (9 bits / 5 bits)		0: relay 1 (trip) 1: relay 2 2: relay 3 3: relay 4 4: watchdog relay 5: relay 5 6: relay 6 7: relay 7 8: relay 8		Data	

Col	Row	Menu Text	Data Type	Ind	Values (*: default)	Depend	Cell Type	Min/Max/Step
	22	Alarm	Binary flag (16 bits)		0: Watchdog 1: Comm err 2: Eeprom err data 3: Ct error 4: Clock error 5: Eeprom err calib 6: Ram error 7: Default settings 8 to 15: reserved		Data	
	23	Pseudo Logic Input Status group 1	Binary flag (16 bits)		0: Ph. A Stage 1 1: Ph. B Stage 1 2: Ph. C Stage 1 3: DZ 4: PD 5: tPh. A Stage 1 6: tPh. B Stage 1 7: tPh. C Stage 1 8: t DZ 9: t PD 10: t Stage 1 11: t Stage 2 12: Ph. A Ext. 13: Ph. B Ext. 14: Ph. C Ext. 15: 3Ph. Ext.		Data	
	24	Pseudo Logic Input Status group 2	Binary flag (16 bits / 6 bits)		0: t Aux 1 1: t Aux 2 2: CB open time ext. 3: CB open time Stage 1 4: CB operation nb 5: SA2n 6 Setting pb. tStage 1 7: Setting pb. DZ 8: Setting pb. PD 9: Security setting pb. 10: Security 1 pb. 11: Security 2 pb. 12: Earth stage 1 13: t Earth stage 1 14: 52A 15: 52B		Data	
	25	SYS Pseudo-TS group 3 Stat	Binary flag (15 bits)		0: Block logic 1 1: Block logic 2 2: External Non I trip 3: Negative inst 4: Negative stage1 5: Phase non I inst 6: Phase non I stage1 7: Earth Non I inst 8: Earth Non I stage1 9: Negative Non I inst 10: Negative Non I stage1 11: Non I stage1 12: Non I stage2 13: CB unhealth stage1 14: CB unhealth stage2 15:			

Col	Row	Menu Text	Data Type	Ind	Values (*: default)	Depend	Cell Type	Min/Max/Step
	26	SYS Pseudo-TS group 4 Stat	Binary flag (8 bits)		0: Equation A 1: Equation B 2: Equation C 3: Equation D 4: Equation E 5: Equation F 6: Equation G 7: Equation H 8:			
01	00	USER CONTROL						
	01	Remote control 1	Binary flag (16 bits)		0: Unlock trip cont.* 1: Ack first alarm 2: Ack all alarms 3: Reserved 4: Reserved 5: Setting Change 6: Reserved 7: Reserved 8: Dist. Rec. Trig 9: Reserved 10: Reserved 11: Reserved 12: Reserved 13: Reserved 14: Reserved 15: SRAM def. ack		Setting	0/ 31/ 1 or 0/65535/1
02	00	FAULT RECORDS						
	01	Record number	Unsigned Integer (2 bytes)			5 *	Setting	1/5/1
	02	Occur date	Unsigned Integer (2 bytes)					
	03	Active set group	Unsigned Integer (2 bytes)					
	04	Phase in fault	ASCII Text					
	05	Fault Id	ASCII Text					
	06	Magnitude	Courier floating point number					
	07	Ia magnitude	Courier floating point number					
	08	Ib magnitude	Courier floating point number					
	09	Ic magnitude	Courier floating point number					
	0A	I0 magnitude	Courier floating point number					
03	00	MEASUREMENTS						
	01	Ia RMS	Courier floating point number				Data	
	02	Ib RMS	Courier floating point number				Data	
	03	Ic RMS	Courier floating point number				Data	
	04	I0 RMS	Courier floating point number				Data	

Col	Row	Menu Text	Data Type	Ind	Values (*: default)	Depend	Cell Type	Min/Max/Step
	05	FREQUENCY	Courier floating point number				Data	
04	00	TRIP STATISTICS						
	01	Reset Trip statistics						
	02	Ext. Trip Triphased Nb	Unsigned Integer (2 bytes)				Data	
	03	Ext. Trip Phase A Nb	Unsigned Integer (2 bytes)				Data	
	04	Ext. Trip Phase B Nb	Unsigned Integer (2 bytes)				Data	
	05	Ext. Trip Phase C Nb	Unsigned Integer (2 bytes)				Data	
	06	Trip Phase A Stage 1 Nb	Unsigned Integer (2 bytes)				Data	
	07	Trip Phase B Stage 1 Nb	Unsigned Integer (2 bytes)				Data	
	08	Trip Phase C Stage 1 Nb	Unsigned Integer (2 bytes)				Data	
	09	Trip Earth Stage 1 Nb	Unsigned Integer (2 bytes)				Data	
	0A	Trip Stage 1 Nb	Unsigned Integer (2 bytes)				Data	
	0B	Trip Stage 2 Nb	Unsigned Integer (2 bytes)				Data	
	0C	Trip Neg. Stage1 Nb	Unsigned Integer (2 bytes)					
	0D	Trip CB Unh. Stg1 Nb	Unsigned Integer (2 bytes)					
	0E	Trip CB Unh. Stg2 Nb	Unsigned Integer (2 bytes)					
	0F	Ext. Non I Trip Nb	Unsigned Integer (2 bytes)					
	10	Trip Phase Non I Stg1 Nb	Unsigned Integer (2 bytes)					
	11	Trip Earth Non I Stg1 Nb	Unsigned Integer (2 bytes)					
	12	Trip Neg. Non I Stg1 Nb	Unsigned Integer (2 bytes)					
	13	Trip Non I Stg2 Nb	Unsigned Integer (2 bytes)					
	14	Trip Non I Stg1 Nb	Unsigned Integer (2 bytes)					
06	00	SW MONITORING						
	01	Reset San Ix						
	02	San IA	Courier floating point number				Data	
	03	San IB	Courier floating point number				Data	
	04	San IC	Courier floating point number				Data	

Col	Row	Menu Text	Data Type	Ind	Values (*: default)	Depend	Cell Type	Min/Max/Step
	05	SW operation nb (Reset)	Unsigned Integer (2 bytes)				Data	
	06	SW operation time	Courier floating point number		0.0 s		Data	
08	00	TIME:						
	01	Date/Time	IEC870 Time & Date				Data	
	02	Date Format (IEC/no)	Indexed String		0: Private * 1: IEC		Setting	0 (Private) / 1 (IEC)
0E	00	CT RATIOS						
	01	Phase CT Primary	Unsigned Integer (2 bytes)		1000 *		Setting	1/3000/1
	02	Phase CT Secondary	Unsigned Integer (2 bytes)		1 *		Setting	1/5/4
	03	Neutral CT Primary	Unsigned Integer (2 bytes)		1000 *		Setting	1/3000/1
	04	Neutral CT Secondary	Unsigned Integer (2 bytes)		1 *		Setting	1/5/4
0F	00	SETTING GROUPS						
	01	Setting group toggle	Indexed String		0: Edge * 1: Level		Setting	0 (Edge) / 1 (Level)
	02	Select setting group	Unsigned Integer (2 bytes)		1*	0F01 = 0	Setting	1/2
	03	Group 1 visible	Indexed String		0: YES * 1: NO		Setting	0 (YES) / 1 (NO)
	04	Group 2 visible	Indexed String		0: YES 1: NO *		Setting	0 (YES) / 1 (NO)
		Protection Group n° 1						
20	00	CB FAIL						
	01	CB Fail ?	Binary (1 bit)	0	Disabled * / Enabled			
	02	CB Fail Phase ?	Binary (1 bit)	0	Disabled * / Enabled	2001 != 0		
	03	Threshold I> BF	Courier floating point number		0.1 *	2001 != 0 AND 2002 != 0	Setting	0.05 / 4.0 / 0.01
	04	CB Fail Earth ?	Binary (1 bit)	0	Disabled * / Enabled	2001 != 0		
	05	Threshold I0> BF	Courier floating point number		0.1 * if normal sensitivity, or 0.05 if sensitive, or 0.25 if great sensitivity	2001 != 0 AND 2004 != 0	Setting	0.05 / 4.0 / 0.01 if normal sensitivity, or 0.01 / 4.0 / 0.01 if sensitive, or 0.02 / 8.0 / 0.01 if great sensitivity
	06	Earth Delay stage1	Courier floating point number		0.01 s *	2001 != 0	Setting	0 / 40.0 / 0.005 s
	07	Earth Delay stage2	Courier floating point number		0.04 s *	2001 != 0	Setting	0 / 40.0 / 0.005 s
	08	Reset Stage 1 setting ?	Binary (1 bit)	0	Disabled * / Enabled	2001 != 0		
	09	Ext Non I Reset by	Unsigned Integer (2 bytes)					
	0A	Phase Delay stage1	Courier floating point number		0.01 s *	2001 != 0 AND 2002 != 0	Setting	0 / 40.0 / 0.005 s

Col	Row	Menu Text	Data Type	Ind	Values (*: default)	Depend	Cell Type	Min/Max/Step
	0B	Phase Delay stage2	Courier floating point number		0.04 s *	2001 != 0 AND 2002 != 0	Setting	0 / 40.0 / 0.005 s
	0C	CB Fail Neg. Seq.	Binary (1 bit)		No / Yes	2001 != 0	Setting	0/1/1
	0D	I2> BF	Courier floating point number		0.05 s *	2001 != 0 AND 200C != 0	Setting	0.05 /2/ 0.01
	0E	Neg. Delay stage 1	Courier floating point number		0.01 s *	2001 != 0 AND 2002 != 0	Setting	0 / 40.0 / 0.005 s
	0F	Neg. Delay stage 2	Courier floating point number		0.04 s *	2001 != 0 AND 2002 != 0	Setting	0 / 40.0 / 0.005 s
	10	CB unh.	Binary (1 bit)		No / Yes	2001 != 0	Setting	0/1/1
	11	CB unh. stage 1	Courier floating point number		0.5 s *	2001 != 0 AND 2010 != 0	Setting	0 / 40.0 / 0.005 s
	12	CB unh. stage 2	Courier floating point number		0.0 s *	2001 != 0 AND 2010 != 0	Setting	0 / 40.0 / 0.005 s
21	00	DEAD ZONE						
	01	Dead zone ?	Binary (1 bit)	0	Disabled * / Enabled			
	02	I DZ>	Courier floating point number		1.0 *	2271 != 0	Setting	0.05 / 4.0 / 0.01
	03	t DZ	Courier floating point number		0.01 s *	2271 != 0	Setting	0 / 40.0 / 0.005 s
	04	Ie DZ>threshold	Courier floating point number		0.1* if normal sensitivity, or 0.05 if sensitive , or 0.25 if great sensitivity	2101!=0	Setting	0.05/4.0/0.01 if normal sensitivity , or 0.01/4.0/0.01 if sensitive, or 0.02/8.0/0.01 if great sensitivity
22	00	POLE DISCREPANCY						
	01	Pole discrepancy ?	Binary (1 bit)	0	Disabled * / Enabled			
	02	I PD>	Courier floating point number		0.80 *	2201 != 0	Setting	0.06 / 4.0 / 0.01
	03	I PD<	Courier floating point number		0.40 *	2201 != 0	Setting	0.05 / 1.0 / 0.01
	04	t PD	Courier floating point number		0.01 s *	2201 != 0	Setting	0 / 40.0 / 0.005 s
		Protection Group n° 2						
40	00	Group 2 CB FAIL						
		Same characteristics as Group n°1: visible if 0F03=1						
41	00	Group 2 DEAD ZONE						
		Same characteristics as Group n°1:						
42	00	Group 2 POLE DISCREPANCY						

Col	Row	Menu Text	Data Type	Ind	Values (*: default)	Depend	Cell Type	Min/Max/Step
		Same characteristics as Group n°1:						
60	00	AUTOMATISM						
	01	Trip Configuration	Binary (10 bits)		0: t Phase A Stage 1 1: t Phase B Stage 1 2: t Phase C Stage 1 3: t Stage 1 4: t Stage 2 5: t DZ 6: t PD 7: t Aux1 8: t Aux2 9: t Earth Stage 1 10: Trip Phase Non I stage1 11: Trip Neg. Non I stage1 12: Trip t Neg. stage1 13: Trip Non I stage1 14: Trip t Unhealthy stage1 15: Trip t Unhealthy stage2		Setting	0/1023/1
	02	Latched Configuration	Binary (10 bits)		0: t Phase A Stage 1 1: t Phase B Stage 1 2: t Phase C Stage 1 3: t Stage 1 4: t Stage 2 5: t DZ 6: t PD 7: t Aux1 8: t Aux2 9: t Earth Stage 1 10: Latch tPh. Non I stage1 11: Latch tNe. Non I stage1 12: Latch tNeg. stage1 13: Latch tNon I stage2 14: Latch tUnhealthy stage1 15: Latch tUnhealthy stage2		Setting	0/1023/1
	03	Trip Configuration (Word2)	Binary (10 bits)		0: Trip Equation A 1: Trip Equation B 2: Trip Equation C 3: Trip Equation D 4: Trip Equation E 5: Trip Equation F 6: Trip Equation G 7: Trip Equation H 8: Trip Earth Non I stage1 9: Trip Non I stage2			
	04	Latched Configuration (Word2)	Binary (2bit)		0: Latch tEa. Non I stage1 1: Trip Non I stage2			

Col	Row	Menu Text	Data Type	Ind	Values (*: default)	Depend	Cell Type	Min/Max/Step
	05	Block Logic 1	Binary (7 bit)		0: CBF phase 1: CBF earth 2: CBF neg. 3: Dead zone 4: Pole discrepancy 5: tAux1 6: tAux2			
	06	Block Logic 2	Binary (7 bit)		Same as 6005			
61	00	AFFECTATION DES TS						
	01	Logical input allocation 1	Binary (16 bit)	0 0 1 2 3 4 5 6 7 8 9 10 11 12 13 14 15	0: nothing * 0: Trip ext. Ph. A 1: Trip ext. Ph. B 2: Trip ext. Ph. C 3: Trip ext. 3Ph. 4: unlatch 5: 52 a 6: 52 b 7: External input 1 8: External input 2 9: Group change 10: Disturbance trig 11: Security 1 12: Security 2 13: Reset LEDs 14: CB unhealthy 15: Block Logic 1		Setting	0 / 15 / 1
	02	Logical input allocation 2	Binary (16 bit)		same as 6101		Setting	0 / 15 / 1
	03	Logical input allocation 3	Binary (16 bit)		same as 6101		Setting	0 / 15 / 1
	04	Logical input allocation 4	Binary (16 bit)		same as 6101		Setting	0 / 15 / 1
	05	Logical input allocation 5	Binary (16 bit)		same as 6101		Setting	0 / 15 / 1
	06	Timer aux 1	Courier floating point number		0 *		Setting	0 / 200.0 / 0.01 s
	07	Timer aux 2	Courier floating point number		0 *		Setting	0 / 200.0 / 0.01 s
	08	TS setting (Edge type)	Binary (5 bits)		Bit 0 to 4 = 0: Rising edge Bit 0 to 4 = 1: Falling edge		Setting	0/31/1
	09	TS voltage	Indexed String		0 * = DC 1 = AC		Setting	0/1/1
	0A	Logic input allocation 1(Word 2)	Binary (3 bit)		0: Block Logic 2 1: SYNCHRO 2: Ext.Non I Trip		Setting	0 / 15 / 1
	0B	Logic input allocation 2(Word 2)	Binary (3 bit)		Same as 610A		Setting	0 / 15 / 1
	0C	Logic input allocation 3(Word 2)	Binary (3 bit)		Same as 610A		Setting	0 / 15 / 1
	0D	Logic input allocation 4(Word 2)	Binary (3 bit)		Same as 610A		Setting	0 / 15 / 1
	0E	Logic input allocation 5(Word 2)	Binary (3 bit)		Same as 610A		Setting	0 / 15 / 1
62	00	TC CONFIGURATION						
	01	t Phase A Stage 1	Binary (7 bits)		0000000 *		Setting	0 / 127 / 1
	02	t Phase B Stage 1	Binary (7 bits)		0000000 *		Setting	0 / 127 / 1

Col	Row	Menu Text	Data Type	Ind	Values (*: default)	Depend	Cell Type	Min/Max/Step
	03	t Phase C Stage 1	Binary (7 bits)		0000000 *		Setting	0 / 127 / 1
	04	t Earth Stage 1	Binary (7 bits)		0000000 *		Setting	0 / 127 / 1
	05	t Stage 1	Binary (7 bits)		0000000 *		Setting	0 / 127 / 1
	06	t Stage 2	Binary (7 bits)		0000000 *		Setting	0 / 127 / 1
	07	t DZ	Binary (7 bits)		0000000 *		Setting	0 / 127 / 1
	08	t PD	Binary (7 bits)		0000000 *		Setting	0 / 127 / 1
	09	tAux 1	Binary (7 bits)		0000000 *		Setting	0 / 127 / 1
	0A	tAux 2	Binary (7 bits)		0000000 *		Setting	0 / 127 / 1
	0B	CB Operation time Ext.	Binary (7 bits)		0000000 *		Setting	0 / 127 / 1
	0C	CB Operation time Stage 1	Binary (7 bits)		0000000 *		Setting	0 / 127 / 1
	0D	CB Operation Nb	Binary (7 bits)		0000000 *		Setting	0 / 127 / 1
	0E	SA2n	Binary (7 bits)		0000000 *		Setting	0 / 127 / 1
	0F	TC lock setting	Binary (7 bits)		0000000 *		Setting	0 / 127 / 1
	11	Ph Non I:8765432stage1	Binary (7 bits)		0000000 *		Setting	0 / 127 / 1
	12	Ea Non I:8765432stage1	Binary (7 bits)		0000000 *		Setting	0 / 127 / 1
	13	Ne Non I:8765432stage1	Binary (7 bits)		0000000 *		Setting	0 / 127 / 1
	14	t Equ. A	Binary (7 bits)		0000000 *		Setting	0 / 127 / 1
	15	t Equ. B	Binary (7 bits)		0000000 *		Setting	0 / 127 / 1
	16	t Equ. C	Binary (7 bits)		0000000 *		Setting	0 / 127 / 1
	17	t Equ. D	Binary (7 bits)		0000000 *		Setting	0 / 127 / 1
	18	t Equ. E	Binary (7 bits)		0000000 *		Setting	0 / 127 / 1
	19	t Equ. F	Binary (7 bits)		0000000 *		Setting	0 / 127 / 1
	1A	t Equ. G	Binary (7 bits)		0000000 *		Setting	0 / 127 / 1
	1B	t Equ. H	Binary (7 bits)		0000000 *		Setting	0 / 127 / 1
	1C	Non I :8765432stage1	Binary (7 bits)		0000000 *		Setting	0 / 127 / 1
	1D	Non I :8765432stage2	Binary (7 bits)		0000000 *		Setting	0 / 127 / 1
	1E	tNeg. :8765432stage1	Binary (7 bits)		0000000 *		Setting	0 / 127 / 1
	1F	CB Unh.:8765432stage1	Binary (7 bits)		0000000 *		Setting	0 / 127 / 1
	20	CB Unh.:8765432stage2	Binary (7 bits)		0000000 *		Setting	0 / 127 / 1
63	00	CONFIGURATION DES LEDS						
	01	LED 5 (1)	Binary (16 bits)	0 1 2 3 4 5 6 7 8 9 10 11 12 13 14 15	0: Trip ext. Ph. A 1: Trip ext. Ph. B 2: Trip ext. Ph. C 3: Trip ext. 3Ph. 4: t Ph. A Stage 1 5: t Ph. B Stage 1 6: t Ph. C Stage 1 7: t Stage 1 8: t Stage 2 9: Pb Security 1 10: Pb Security 2 11: t DZ 12: t PD 13: t Aux1 14: t Aux2 15: t Earth Stage 1		Setting	0/ 65535/ 1
	02	LED 6 (1)	Binary (16 bits)	0-15	0-15: Same as 6301		Setting	0/ 65535/ 1
	03	LED 7 (1)	Binary (16 bits)	0-15	0-15: Same as 6301		Setting	0/ 65535/ 1

Col	Row	Menu Text	Data Type	Ind	Values (*: default)	Depend	Cell Type	Min/Max/Step
	04	LED 8 (1)	Binary (16 bits)	0-15	0-15: Same as 6301		Setting	0/ 65535/ 1
	05	LED 5 (2)	Binary (16 bits)	0 1 2 3 4 5 6 7 8 9 10 11 12 13 14 15	0: CB Operation time Ext. 1: CB Operation Nb 2: Sum A n 3: CB Operation time Stage1 4: t Earth Non I stage1 5: t Neg. Non I stage1 6: t Neg. stage1 7: t Non I stage1 8: t Unhealthy stage1 9: t Unhealthy stage2 10: t Equ. A 11: t Equ. B 12: t Equ. C 13: t Equ. D 14: t Equ. E 15: t Equ. F		Setting	0/ 15/ 1
	06	LED 6 (2)	Binary (16 bits)		same as 6305		Setting	0/ 15/ 1
	07	LED 7 (2)	Binary (16 bits)		same as 6305		Setting	0/ 15/ 1
	08	LED 8 (2)	Binary (16 bits)		same as 6305		Setting	0/ 15/ 1
	09	LED 5 (3)	Binary (4 bits)		0: t Equ. G 1: t Equ. H 2: t Phase.Non I Stage1 3: t Non I stage2			
	10	LED 6 (3)	Binary (4 bits)		Same as 6309			
	11	LED 7 (3)	Binary (4 bits)		Same as 6309			
	12	LED 8 (3)	Binary (4 bits)		Same as 6309			
64	00	ALARMS						
	01	Instant. alarm self-reset	Binary (1 bits)		Disabled * / Enabled		Setting	0/1/1
	02	Battery alarm	Binary (1 bits)		Disabled * / Enabled		Setting	0/1/1
65	00	WIRING SECURITY						
	01	Wiring security ?	Binary (1 bits)		Disabled * / Enabled		Setting	0/1/1
	02	Relay security 1	Indexed String	0 1 2 3 4 5 6 7 8	0: none * 1: Relay 1 2: Relay 2 3: Relay 3 4: Relay 4 5: Relay 5 6: Relay 6 7: Relay 7 8: Relay 8		Setting	0/8/1
	03	Relay security 2	Indexed String	0 1 2 3 4 5 6 7 8	0: none * 1: Relay 1 2: Relay 2 3: Relay 3 4: Relay 4 5: Relay 5 6: Relay 6 7: Relay 7 8: Relay 8		Setting	0/8/1
66	0	EQUATION LOG 1/2						
	10	EQUATION A						

Col	Row	Menu Text	Data Type	Ind	Values (*: default)	Depend	Cell Type	Min/Max/Step
	11	Equation A Operator 0	Indexed String	0 1	NULL NOT		Setting	3/1/2001
	12	Equation A Operand 0	Indexed String	0 1 2 3 4 5 6 7 8 9 10 11 12 13 14 15 16 17 18 19 20 21 22 23 24 25 26 27	None t Ph. A Stage 1 t Ph. B Stage 1 t Ph. C Stage 1 t Earth Non I stage1 t Earth Stage 1 t Neg. Non I stage1 t Neg. Stage 1 t Phase.Non I Stage1 t unhealthy. stage 1 t unhealthy. stage 2 t Stage 1 t Stage 2 t dead Zone t Pole Discre. t Aux1 t Aux2 CB open ext. CB open st. 1 CB NB. op. Sum A n Input 1 Input 2 Input 3 Input 4 Input 5 t Non I stage1 t Non I stage2		Setting	01/0FFF/1
	13	Equation A Operator 1	Indexed String		OR OR NOT AND AND NOT		Setting	01/0FFF/1
	14	Equation A Operand 1	Indexed String				Setting	01/0FFF/1
	15	Equation A Operator 2	Indexed String				Setting	01/0FFF/1
	16	Equation A Operand 2	Indexed String				Setting	01/0FFF/1
	17	Equation A Operator 3	Indexed String				Setting	01/0FFF/1
	18	Equation A Operand 3	Indexed String				Setting	01/0FFF/1
	19	Equation A Operator 4	Indexed String				Setting	01/0FFF/1
	1A	Equation A Operand 4	Indexed String				Setting	01/0FFF/1
	1B	Equation A Operator 5	Indexed String				Setting	01/0FFF/1
	1C	Equation A Operand 5	Indexed String				Setting	01/0FFF/1
	1D	Equation A Operator 6	Indexed String				Setting	01/0FFF/1
	1E	Equation A Operand 6	Indexed String				Setting	01/0FFF/1
	1F	Equation A Operator 7	Indexed String				Setting	01/0FFF/1
	20	Equation A Operand 7	Indexed String				Setting	01/0FFF/1
	21	Equation A Operator 8	Indexed String				Setting	01/0FFF/1
	22	Equation A Operand 8	Indexed String				Setting	01/0FFF/1
	23	Equation A Operator 9	Indexed String				Setting	01/0FFF/1
	24	Equation A Operand 9	Indexed String				Setting	01/0FFF/1
	25	Equation A Operator 10	Indexed String				Setting	01/0FFF/1
	26	Equation A Operand 10	Indexed String				Setting	01/0FFF/1

Col	Row	Menu Text	Data Type	Ind	Values (*: default)	Depend	Cell Type	Min/Max/Step
	27	Equation A Operator 11	Indexed String				Setting	01/0FFF/1
	28	Equation A Operand 11	Indexed String				Setting	01/0FFF/1
	29	Equation A Operator 12	Indexed String				Setting	01/0FFF/1
	2A	Equation A Operand 12	Indexed String				Setting	01/0FFF/1
	2B	Equation A Operator 13	Indexed String				Setting	01/0FFF/1
	2C	Equation A Operand 13	Indexed String				Setting	01/0FFF/1
	2D	Equation A Operator 14	Indexed String				Setting	01/0FFF/1
	2E	Equation A Operand 14	Indexed String				Setting	01/0FFF/1
	2F	Equation A Operator 15	Indexed String				Setting	01/0FFF/1
	30	Equation A Operand 15	Indexed String				Setting	01/0FFF/1
	40	EQUATION B						
	41	Equation B Operator 0	Indexed String				Setting	3/1/2001
	42	Equation B Operand 0	Indexed String				Setting	01/0FFF/1
	43	Equation B Operator 1	Indexed String				Setting	01/0FFF/1
	44	Equation B Operand 1	Indexed String				Setting	01/0FFF/1
	45	Equation B Operator 2	Indexed String				Setting	01/0FFF/1
	46	Equation B Operand 2	Indexed String				Setting	01/0FFF/1
	47	Equation B Operator 3	Indexed String				Setting	01/0FFF/1
	48	Equation B Operand 3	Indexed String				Setting	01/0FFF/1
	49	Equation B Operator 4	Indexed String				Setting	01/0FFF/1
	4A	Equation B Operand 4	Indexed String				Setting	01/0FFF/1
	4B	Equation B Operator 5	Indexed String				Setting	01/0FFF/1
	4C	Equation B Operand 5	Indexed String				Setting	01/0FFF/1
	4D	Equation B Operator 6	Indexed String				Setting	01/0FFF/1
	4E	Equation B Operand 6	Indexed String				Setting	01/0FFF/1
	4F	Equation B Operator 7	Indexed String				Setting	01/0FFF/1
	50	Equation B Operand 7	Indexed String				Setting	01/0FFF/1
	51	Equation B Operator 8	Indexed String				Setting	01/0FFF/1
	52	Equation B Operand 8	Indexed String				Setting	01/0FFF/1
	53	Equation B Operator 9	Indexed String				Setting	01/0FFF/1
	54	Equation B Operand 9	Indexed String				Setting	01/0FFF/1
	55	Equation B Operator 10	Indexed String				Setting	01/0FFF/1
	56	Equation B Operand 10	Indexed String				Setting	01/0FFF/1
	57	Equation B Operator 11	Indexed String				Setting	01/0FFF/1
	58	Equation B Operand 11	Indexed String				Setting	01/0FFF/1
	59	Equation B Operator 12	Indexed String				Setting	01/0FFF/1
	5A	Equation B Operand 12	Indexed String				Setting	01/0FFF/1
	5B	Equation B Operator 13	Indexed String				Setting	01/0FFF/1
	5C	Equation B Operand 13	Indexed String				Setting	01/0FFF/1
	5D	Equation B Operator 14	Indexed String				Setting	01/0FFF/1
	5E	Equation B Operand 14	Indexed String				Setting	01/0FFF/1
	5F	Equation B Operator 15	Indexed String				Setting	01/0FFF/1
	60	Equation B Operand 15	Indexed String				Setting	01/0FFF/1
	70	EQUATION C						

Col	Row	Menu Text	Data Type	Ind	Values (*: default)	Depend	Cell Type	Min/Max/Step
	71	Equation C Operator 0	Indexed String				Setting	3/1/2001
	72	Equation C Operand 0	Indexed String				Setting	01/0FFF/1
	73	Equation C Operator 1	Indexed String				Setting	01/0FFF/1
	74	Equation C Operand 1	Indexed String				Setting	01/0FFF/1
	75	Equation C Operator 2	Indexed String				Setting	01/0FFF/1
	76	Equation C Operand 2	Indexed String				Setting	01/0FFF/1
	77	Equation C Operator 3	Indexed String				Setting	01/0FFF/1
	78	Equation C Operand 3	Indexed String				Setting	01/0FFF/1
	79	Equation C Operator 4	Indexed String				Setting	01/0FFF/1
	7A	Equation C Operand 4	Indexed String				Setting	01/0FFF/1
	7B	Equation C Operator 5	Indexed String				Setting	01/0FFF/1
	7C	Equation C Operand 5	Indexed String				Setting	01/0FFF/1
	7D	Equation C Operator 6	Indexed String				Setting	01/0FFF/1
	7E	Equation C Operand 6	Indexed String				Setting	01/0FFF/1
	7F	Equation C Operator 7	Indexed String				Setting	01/0FFF/1
	80	Equation C Operand 7	Indexed String				Setting	01/0FFF/1
	81	Equation C Operator 8	Indexed String				Setting	01/0FFF/1
	82	Equation C Operand 8	Indexed String				Setting	01/0FFF/1
	83	Equation C Operator 9	Indexed String				Setting	01/0FFF/1
	84	Equation C Operand 9	Indexed String				Setting	01/0FFF/1
	85	Equation C Operator 10	Indexed String				Setting	01/0FFF/1
	86	Equation C Operand 10	Indexed String				Setting	01/0FFF/1
	87	Equation C Operator 11	Indexed String				Setting	01/0FFF/1
	88	Equation C Operand 11	Indexed String				Setting	01/0FFF/1
	89	Equation C Operator 12	Indexed String				Setting	01/0FFF/1
	8A	Equation C Operand 12	Indexed String				Setting	01/0FFF/1
	8B	Equation C Operator 13	Indexed String				Setting	01/0FFF/1
	8C	Equation C Operand 13	Indexed String				Setting	01/0FFF/1
	8D	Equation C Operator 14	Indexed String				Setting	01/0FFF/1
	8E	Equation C Operand 14	Indexed String				Setting	01/0FFF/1
	8F	Equation C Operator 15	Indexed String				Setting	01/0FFF/1
	90	Equation C Operand 15	Indexed String				Setting	01/0FFF/1
	A0	EQUATION C						
	A1	Equation D Operator 0	Indexed String				Setting	3/1/2001
	A2	Equation D Operand 0	Indexed String				Setting	01/0FFF/1
	A3	Equation D Operator 1	Indexed String				Setting	01/0FFF/1
	A4	Equation D Operand 1	Indexed String				Setting	01/0FFF/1
	A5	Equation D Operator 2	Indexed String				Setting	01/0FFF/1
	A6	Equation D Operand 2	Indexed String				Setting	01/0FFF/1
	A7	Equation D Operator 3	Indexed String				Setting	01/0FFF/1
	A8	Equation D Operand 3	Indexed String				Setting	01/0FFF/1
	A9	Equation D Operator 4	Indexed String				Setting	01/0FFF/1
	AA	Equation D Operand 4	Indexed String				Setting	01/0FFF/1
	AB	Equation D Operator 5	Indexed String				Setting	01/0FFF/1

Col	Row	Menu Text	Data Type	Ind	Values (*: default)	Depend	Cell Type	Min/Max/Step
	AC	Equation D Operand 5	Indexed String				Setting	01/0FFF/1
	AD	Equation D Operator 6	Indexed String				Setting	01/0FFF/1
	AE	Equation D Operand 6	Indexed String				Setting	01/0FFF/1
	AF	Equation D Operator 7	Indexed String				Setting	01/0FFF/1
	B0	Equation D Operand 7	Indexed String				Setting	01/0FFF/1
	B1	Equation D Operator 8	Indexed String				Setting	01/0FFF/1
	B2	Equation D Operand 8	Indexed String				Setting	01/0FFF/1
	B3	Equation D Operator 9	Indexed String				Setting	01/0FFF/1
	B4	Equation D Operand 9	Indexed String				Setting	01/0FFF/1
	B5	Equation D Operator 10	Indexed String				Setting	01/0FFF/1
	B6	Equation D Operand 10	Indexed String				Setting	01/0FFF/1
	B7	Equation D Operator 11	Indexed String				Setting	01/0FFF/1
	B8	Equation D Operand 11	Indexed String				Setting	01/0FFF/1
	B9	Equation D Operator 12	Indexed String				Setting	01/0FFF/1
	BA	Equation D Operand 12	Indexed String				Setting	01/0FFF/1
	BB	Equation D Operator 13	Indexed String				Setting	01/0FFF/1
	BC	Equation D Operand 13	Indexed String				Setting	01/0FFF/1
	BD	Equation D Operator 14	Indexed String				Setting	01/0FFF/1
	BE	Equation D Operand 14	Indexed String				Setting	01/0FFF/1
	BF	Equation D Operator 15	Indexed String				Setting	01/0FFF/1
	C0	Equation D Operand 15	Indexed String				Setting	01/0FFF/1
67	0	EQUATION LOG 2/2						
	10	EQUATION E						
	11	Equation E Operator 0	Indexed String				Setting	3/1/2001
	12	Equation E Operand 0	Indexed String				Setting	01/0FFF/1
	13	Equation E Operator 1	Indexed String				Setting	01/0FFF/1
	14	Equation E Operand 1	Indexed String				Setting	01/0FFF/1
	15	Equation E Operator 2	Indexed String				Setting	01/0FFF/1
	16	Equation E Operand 2	Indexed String				Setting	01/0FFF/1
	17	Equation E Operator 3	Indexed String				Setting	01/0FFF/1
	18	Equation E Operand 3	Indexed String				Setting	01/0FFF/1
	19	Equation E Operator 4	Indexed String				Setting	01/0FFF/1
	1A	Equation E Operand 4	Indexed String				Setting	01/0FFF/1
	1B	Equation E Operator 5	Indexed String				Setting	01/0FFF/1
	1C	Equation E Operand 5	Indexed String				Setting	01/0FFF/1
	1D	Equation E Operator 6	Indexed String				Setting	01/0FFF/1
	1E	Equation E Operand 6	Indexed String				Setting	01/0FFF/1
	1F	Equation E Operator 7	Indexed String				Setting	01/0FFF/1
	20	Equation E Operand 7	Indexed String				Setting	01/0FFF/1
	21	Equation E Operator 8	Indexed String				Setting	01/0FFF/1
	22	Equation E Operand 8	Indexed String				Setting	01/0FFF/1
	23	Equation E Operator 9	Indexed String				Setting	01/0FFF/1
	24	Equation E Operand 9	Indexed String				Setting	01/0FFF/1
	25	Equation E Operator 10	Indexed String				Setting	01/0FFF/1

Col	Row	Menu Text	Data Type	Ind	Values (*: default)	Depend	Cell Type	Min/Max/Step
	26	Equation E Operand 10	Indexed String				Setting	01/0FFF/1
	27	Equation E Operator 11	Indexed String				Setting	01/0FFF/1
	28	Equation E Operand 11	Indexed String				Setting	01/0FFF/1
	29	Equation E Operator 12	Indexed String				Setting	01/0FFF/1
	2A	Equation E Operand 12	Indexed String				Setting	01/0FFF/1
	2B	Equation E Operator 13	Indexed String				Setting	01/0FFF/1
	2C	Equation E Operand 13	Indexed String				Setting	01/0FFF/1
	2D	Equation E Operator 14	Indexed String				Setting	01/0FFF/1
	2E	Equation E Operand 14	Indexed String				Setting	01/0FFF/1
	2F	Equation E Operator 15	Indexed String				Setting	01/0FFF/1
	30	Equation E Operand 15	Indexed String				Setting	01/0FFF/1
	40	EQUATION F						
	41	Equation F Operator 0	Indexed String				Setting	3/1/2001
	42	Equation F Operand 0	Indexed String				Setting	01/0FFF/1
	43	Equation F Operator 1	Indexed String				Setting	01/0FFF/1
	44	Equation F Operand 1	Indexed String				Setting	01/0FFF/1
	45	Equation F Operator 2	Indexed String				Setting	01/0FFF/1
	46	Equation F Operand 2	Indexed String				Setting	01/0FFF/1
	47	Equation F Operator 3	Indexed String				Setting	01/0FFF/1
	48	Equation F Operand 3	Indexed String				Setting	01/0FFF/1
	49	Equation F Operator 4	Indexed String				Setting	01/0FFF/1
	4A	Equation F Operand 4	Indexed String				Setting	01/0FFF/1
	4B	Equation F Operator 5	Indexed String				Setting	01/0FFF/1
	4C	Equation F Operand 5	Indexed String				Setting	01/0FFF/1
	4D	Equation F Operator 6	Indexed String				Setting	01/0FFF/1
	4E	Equation F Operand 6	Indexed String				Setting	01/0FFF/1
	4F	Equation F Operator 7	Indexed String				Setting	01/0FFF/1
	50	Equation F Operand 7	Indexed String				Setting	01/0FFF/1
	51	Equation F Operator 8	Indexed String				Setting	01/0FFF/1
	52	Equation F Operand 8	Indexed String				Setting	01/0FFF/1
	53	Equation F Operator 9	Indexed String				Setting	01/0FFF/1
	54	Equation F Operand 9	Indexed String				Setting	01/0FFF/1
	55	Equation F Operator 10	Indexed String				Setting	01/0FFF/1
	56	Equation F Operand 10	Indexed String				Setting	01/0FFF/1
	57	Equation F Operator 11	Indexed String				Setting	01/0FFF/1
	58	Equation F Operand 11	Indexed String				Setting	01/0FFF/1
	59	Equation F Operator 12	Indexed String				Setting	01/0FFF/1
	5A	Equation F Operand 12	Indexed String				Setting	01/0FFF/1
	5B	Equation F Operator 13	Indexed String				Setting	01/0FFF/1
	5C	Equation F Operand 13	Indexed String				Setting	01/0FFF/1
	5D	Equation F Operator 14	Indexed String				Setting	01/0FFF/1
	5E	Equation F Operand 14	Indexed String				Setting	01/0FFF/1
	5F	Equation F Operator 15	Indexed String				Setting	01/0FFF/1
	60	Equation F Operand 15	Indexed String				Setting	01/0FFF/1

Col	Row	Menu Text	Data Type	Ind	Values (*: default)	Depend	Cell Type	Min/Max/Step
	70	EQUATION G						
	71	Equation G Operator 0	Indexed String				Setting	3/1/2001
	72	Equation G Operand 0	Indexed String				Setting	01/0FFF/1
	73	Equation G Operator 1	Indexed String				Setting	01/0FFF/1
	74	Equation G Operand 1	Indexed String				Setting	01/0FFF/1
	75	Equation G Operator 2	Indexed String				Setting	01/0FFF/1
	76	Equation G Operand 2	Indexed String				Setting	01/0FFF/1
	77	Equation G Operator 3	Indexed String				Setting	01/0FFF/1
	78	Equation G Operand 3	Indexed String				Setting	01/0FFF/1
	79	Equation G Operator 4	Indexed String				Setting	01/0FFF/1
	7A	Equation G Operand 4	Indexed String				Setting	01/0FFF/1
	7B	Equation G Operator 5	Indexed String				Setting	01/0FFF/1
	7C	Equation G Operand 5	Indexed String				Setting	01/0FFF/1
	7D	Equation G Operator 6	Indexed String				Setting	01/0FFF/1
	7E	Equation G Operand 6	Indexed String				Setting	01/0FFF/1
	7F	Equation G Operator 7	Indexed String				Setting	01/0FFF/1
	80	Equation G Operand 7	Indexed String				Setting	01/0FFF/1
	81	Equation G Operator 8	Indexed String				Setting	01/0FFF/1
	82	Equation G Operand 8	Indexed String				Setting	01/0FFF/1
	83	Equation G Operator 9	Indexed String				Setting	01/0FFF/1
	84	Equation G Operand 9	Indexed String				Setting	01/0FFF/1
	85	Equation G Operator 10	Indexed String				Setting	01/0FFF/1
	86	Equation G Operand 10	Indexed String				Setting	01/0FFF/1
	87	Equation G Operator 11	Indexed String				Setting	01/0FFF/1
	88	Equation G Operand 11	Indexed String				Setting	01/0FFF/1
	89	Equation G Operator 12	Indexed String				Setting	01/0FFF/1
	8A	Equation G Operand 12	Indexed String				Setting	01/0FFF/1
	8B	Equation G Operator 13	Indexed String				Setting	01/0FFF/1
	8C	Equation G Operand 13	Indexed String				Setting	01/0FFF/1
	8D	Equation G Operator 14	Indexed String				Setting	01/0FFF/1
	8E	Equation G Operand 14	Indexed String				Setting	01/0FFF/1
	8F	Equation G Operator 15	Indexed String				Setting	01/0FFF/1
	90	Equation G Operand 15	Indexed String				Setting	01/0FFF/1
	A0	EQUATION H						
	A1	Equation H Operator 0	Indexed String				Setting	3/1/2001
	A2	Equation H Operand 0	Indexed String				Setting	01/0FFF/1
	A3	Equation H Operator 1	Indexed String				Setting	01/0FFF/1
	A4	Equation H Operand 1	Indexed String				Setting	01/0FFF/1
	A5	Equation H Operator 2	Indexed String				Setting	01/0FFF/1
	A6	Equation H Operand 2	Indexed String				Setting	01/0FFF/1
	A7	Equation H Operator 3	Indexed String				Setting	01/0FFF/1
	A8	Equation H Operand 3	Indexed String				Setting	01/0FFF/1
	A9	Equation H Operator 4	Indexed String				Setting	01/0FFF/1
	AA	Equation H Operand 4	Indexed String				Setting	01/0FFF/1

Col	Row	Menu Text	Data Type	Ind	Values (*: default)	Depend	Cell Type	Min/Max/Step
	AB	Equation H Operator 5	Indexed String				Setting	01/0FFF/1
	AC	Equation H Operand 5	Indexed String				Setting	01/0FFF/1
	AD	Equation H Operator 6	Indexed String				Setting	01/0FFF/1
	AE	Equation H Operand 6	Indexed String				Setting	01/0FFF/1
	AF	Equation H Operator 7	Indexed String				Setting	01/0FFF/1
	B0	Equation H Operand 7	Indexed String				Setting	01/0FFF/1
	B1	Equation H Operator 8	Indexed String				Setting	01/0FFF/1
	B2	Equation H Operand 8	Indexed String				Setting	01/0FFF/1
	B3	Equation H Operator 9	Indexed String				Setting	01/0FFF/1
	B4	Equation H Operand 9	Indexed String				Setting	01/0FFF/1
	B5	Equation H Operator 10	Indexed String				Setting	01/0FFF/1
	B6	Equation H Operand 10	Indexed String				Setting	01/0FFF/1
	B7	Equation H Operator 11	Indexed String				Setting	01/0FFF/1
	B8	Equation H Operand 11	Indexed String				Setting	01/0FFF/1
	B9	Equation H Operator 12	Indexed String				Setting	01/0FFF/1
	BA	Equation H Operand 12	Indexed String				Setting	01/0FFF/1
	BB	Equation H Operator 13	Indexed String				Setting	01/0FFF/1
	BC	Equation H Operand 13	Indexed String				Setting	01/0FFF/1
	BD	Equation H Operator 14	Indexed String				Setting	01/0FFF/1
	BE	Equation H Operand 14	Indexed String				Setting	01/0FFF/1
	BF	Equation H Operator 15	Indexed String				Setting	01/0FFF/1
	C0	Equation H Operand 15	Indexed String				Setting	01/0FFF/1
68	0	LOGIC EQUAT T DELAY						
	1	Equation A Rising Timer	Courier floating point number		0s		Setting	0/600/0.01
	2	Equation A Falling Timer	Courier floating point number		0s		Setting	0/600/0.01
	3	Equation B Rising Timer	Courier floating point number		0s		Setting	0/600/0.01
	4	Equation B Falling Timer	Courier floating point number		0s		Setting	0/600/0.01
	5	Equation C Rising Timer	Courier floating point number		0s		Setting	0/600/0.01
	6	Equation C Falling Timer	Courier floating point number		0s		Setting	0/600/0.01
	7	Equation D Rising Timer	Courier floating point number		0s		Setting	0/600/0.01
	8	Equation D Falling Timer	Courier floating point number		0s		Setting	0/600/0.01
	9	Equation E Rising Timer	Courier floating point number		0s		Setting	0/600/0.01
	A	Equation E Falling Timer	Courier floating point number		0s		Setting	0/600/0.01
	B	Equation F Rising Timer	Courier floating point number		0s		Setting	0/600/0.01
	C	Equation F Falling Timer	Courier floating point number		0s		Setting	0/600/0.01

Col	Row	Menu Text	Data Type	Ind	Values (*: default)	Depend	Cell Type	Min/Max/Step
	D	Equation G Rising Timer	Courier floating point number		0s		Setting	0/600/0.01
	E	Equation G Falling Timer	Courier floating point number		0s		Setting	0/600/0.01
	F	Equation H Rising Timer	Courier floating point number		0s		Setting	0/600/0.01
	10	Equation H Falling Timer	Courier floating point number		0s		Setting	0/600/0.01
69	00	SW SUPERVISION						
	01	SW Operating time?	Binary (1 bit)	0	Disabled * / Enabled		Setting	0/1/1
	02	SW Operating time	Courier floating point number		0.10 s*	6901 = 1	Setting	0.10 / 5.0 / 0.10 s
	03	SW Operating number?	Binary (1 bit)	0	Disabled * / Enabled		Setting	0/1/1
	04	SW Operating number	Unsigned Integer (2 bytes)		0 *	6903 = 1	Setting	0/ 50000/ 1
	05	SA2n ?	Binary (1 bit)	0	Disabled * / Enabled		Setting	0/1/1
	06	SA2n	Courier floating point number		0 exp+06 A² *	6905 = 1	Setting	0/4000/1 (*exp+06)
	07	n	Unsigned Integer (2 bytes)		1 *	6905 = 1	Setting	1/2/1
	08	TRIP t	Courier floating point number		0.1 s*		Setting	0.1 / 5.0 / 0.05 s
70	00	RECORDER CONTROL	(VERSION P922 et >)					
	01	Start/Trigger recorder	Indexed String	0 1 2	Stopped Triggerred Running *		Setting	1/2/1
	02	Recorder Source	Indexed String	0	Samples *		Data	
	20	Pretemps	Courier floating point number		0.1 secondes		Setting	0.1 / 3.0 / 0.1 s
	21	Postemps	Courier floating point number		0.1 secondes		Setting	0.1 / 3.0 / 0.1 s
	22	Disturbance rec. trig	Indexed String	0	ON INST* / ON TRIG		Setting	0 / 1 / 1
80	00	DISTURBANCE REC	(VERSION P922 et >)					
	01	Record Number	Unsigned integer (1 byte)		0*		Setting	0/5/1 (selon contexte)
	02	Trigger Time	IEC870 Time & Date		dd/mm/yy hh:mm		Data	
	03	Available Channel Bit Mask	Binary Flag Indexed String	0 1 2 3 4	11111 "Ua" "Ub" "Uc" "V0" "Inputs/Outputs"		Data	
	04	Channel Types	Binary Flag 0: digital, 1: analogue		01111		Data	
	05	Channel Offsets	Repeated group of Courier numbers		Upload Offsets		Data	
	06	Scaling Factors	Repeated group of Courier numbers		Upload Scal. Factors		Data	
	07-0F	NON IMPLEMENTE - réservé						
	10	Record Length	Integer (2 bytes)				Data	
	11	Trigger position	Integer (2 bytes)				Data	

Col	Row	Menu Text	Data Type	Ind	Values (*: default)	Depend	Cell Type	Min/Max/Step
	12	Time Base	Courier floating point number				Data	
	13	NON IMPLEMENTED - reserved						
	14	Upload Timer	Repeated group of Integers				Data	
	15-1F	NON IMPLEMENTED - reserved						
	20	Upload Channel 0	Repeated group of Integers				Data	
	21	Upload Channel 1	Repeated group of Integers				Data	
	22	Upload Channel 2	Repeated group of Integers				Data	
	23	Upload Channel 3	Repeated group of Integers				Data	
	24	Upload Channel Inputs/Outputs	Repeated group of Integer/Bin. flags				Data	
90	00	AUTOMAT. FLT	(VERSION P922 et >)					
	01	Record number	Unsigned Integer (2 bytes)				Setting (automatic)	
	02	Occur fault date	Unsigned Integer (2 bytes)				Data	
	03	Active set group	Unsigned Integer (2 bytes)	1			Data	
	04	Phase in fault	ASCII Text (10 bytes)	"PHASE A"			Data	
	05	Fault Id	ASCII Text (18 bytes)	"I >>"			Data	
	06	Magnitude	Courier floating point number	12.34 A			Data	
	07	Ia Magnitude	Courier floating point number	12.34 A			Data	
	08	Ib Magnitude	Courier floating point number	12.34 A			Data	
	09	Ic Magnitude	Courier floating point number	12.34 A			Data	
	0A	In Magnitude	Courier floating point number	12.34 A			Data	
BF	00	COMM SYSTEM DATA						
	01	Dist Record Cntrl Ref	Menu Cell (2)	0x7000			Data	
	02	Dist Record Extract Ref	Menu Cell (2)	0x8000			Data	
	03	Setting Transfert	Unsigned Integer (2 bytes)	0 *			Data	0 / 1 / 1
	04	Reset Demand Timers	NON IMPLEMENTED					
	05	Reset Event Report	NON IMPLEMENTED					

Table 34 - Relay Courier Database

3 IEC60870-5-103 INTERFACE

The IEC60870-5-103 interface is a master/slave interface with the relay as the slave device. This protocol is based on the VDEW communication protocol. The relay conforms to compatibility level 2, compatibility level 3 not supported.

The following IEC60870-5-103 facilities are supported by this interface:

- Initialization (Reset)
- Time synchronization
- Event Record Extraction
- General Interrogation
- Cyclic Measurements
- General Commands

3.1 Physical Connection and Link Layer

Connection is available for IEC60870-5-103 through the rear RS485 port. It is possible to select the relay address and baud rate using the front panel interface. Following a change, a reset command is required to re-establish communications.

The parameters of the communication are the following:

- Even Parity
- 8 Data bits
- 1 stop bit
- Data rate 9600 or 19200 bauds.

3.2 Initialization

Whenever the relay is powered up, or when the communication parameters are modified, a reset command is required to initialize the communications. The relay will respond to either of the two reset commands (Reset CU or Reset FCB), the difference being that the Reset CU will clear any message which is not sent in the relay's transmit buffer.

The relay will respond to the reset command with an identification message ASDU5, the Cause Of Transmission (COT) of this response will be either Reset CU or Reset FCB depending on the nature of the reset command. This information will be contained in the data section of this ASDU:

Manufacturer Name: Schneider Electric

The Software Identification Section will contain the first four characters of the relay model number to identify the type of relay, e.g. P821.

In addition to the above identification message, if the relay has been powered up, it will also produce a power up event.

3.3 Time Synchronization

The relay time and date can be set using the time synchronization feature of the IEC60870-5-103 protocol. The relay will correct the transmission delay as specified in the IEC60870-5-103. If the time synchronization message is sent as a send/confirm message then the relay will respond with a confirm. If the time synchronization message is sent as a sent/confirm or broadcast (send/no reply) message, a time synchronization message will be returned as class 1 data.

3.4 Spontaneous Events

The event created by the relay will be passed using the standard function type/information numbers to the IEC60870-5-103 master station. Private codes are not used, thus any event that can not pass using standardized messages will not be sent

Events are categorized using the following information:

- Common Address
- Function type
- Information number

Appendix 2 - IEC 60870-5-103 Databases contains a complete listing of all events produced by the relay. The common address is used to differentiate in circumstances where the relay produces more events of a certain type than can be passed using the standardized messages.

Using the different common address for the breaker fail stages allows each stage to be indicated. Appendix 2 - IEC 60870-5-103 Databases shows the common address as an offset value. The common address offset will be added to the station address in order to pass these events.

3.5 General Interrogation

The GI request can be used to read the status of the relay. The function numbers, information numbers and common address offsets that will be returned during the GI cycle are indicated in Appendix 2 - IEC 60870-5-103 Databases.

3.6 Cyclic Measurements

The relay will produce measured value using ASDU 9 on a cyclic basis, this can be read from the relay using a class 2 poll.

Note that the measurands transmitted by the relay are sent as a proportion of either 1.2 or 2.4 times the rated value of the analogue value. The selection of either 1.2 or 2.4 for a particular value is indicated in Appendix 2 - IEC 60870-5-103 Databases.

3.7 Commands

A list of the supported commands is contained in Appendix 2 - IEC 60870-5-103 Databases. The relay will respond to other commands with an ASDU 1, with a Cause Of Transmission (COT) of negative acknowledgement of a command.

3.8 Disturbance Records

The disturbance records stored by the relay can not be extracted using the mechanism defined in the IEC60870-5-103 standard. The relay maintains compatibility with the VDEW control system by transmitting an ASDU 23 with no disturbance records at the start of every GI cycle.

3.9 Blocking of Monitor Direction

The relay does not support a facility to block messages in the Monitor direction.

3.10 Appendix 2 - IEC 60870-5-103 Databases

An event is always generated on the rising edge of the information.

Some events can be generated on the rising or lowering edge.

In the list below, events only generated on rising edge will be tagged with a "**

3.10.1 List of Events Produced by the Relay

Two types of ASDU can be generated for events: ASDU 1 (time-tagged message) or ASDU 2 (time-tagged message with relative time).

The list of processed events is as follows, with the associated FUNCTION TYPE, INFORMATION NUMBER, ASDU TYPE and CAUSE OF TRANSMISSION.

- FUN <226>: Function type in Public range for Breaker Failure Protections (compatible range).
- FUN <227>: Function type in Private range (Reserved for Breaker Failure Protections).

Status Indications (Monitor Direction)				
Description	FUN	INF	TYP	COT
LEDs reset	<226>	<19>	<1>	<1> *
Local parameter Setting active	<226>	<22>	<1>	<1>
Setting Group number 1 active	<226>	<23>	<1>	<1>
Setting Group number 2 active	<226>	<24>	<1>	<1>
Auxiliary input 1	<226>	<27>	<1>	<1>
Auxiliary input 2	<226>	<28>	<1>	<1>

Relay Indications				
Description	FUN	INF	TYP	COT
Trip relay latch active	<227>	<229>	<1>	<1>
Auxiliary relay latch	<227>	<230>	<1>	<1>
Trip relay unlatch (Front panel, Comm. or logical inp.)	<227>	<152>	<1>	<1>
Auxiliary relay unlatch (Front panel)	<227>	<153>	<1>	<1>
Security 1 Input	<227>	<120>	<1>	<1>
Security 2 Input	<227>	<121>	<1>	<1>

Logical Status				
Description	FUN	INF	TYP	COT
Logical input 1	<227>	<160>	<1>	<1>
Logical input 2	<227>	<161>	<1>	<1>
Logical input 3	<227>	<162>	<1>	<1>
Logical input 4	<227>	<163>	<1>	<1>
Logical input 5	<227>	<164>	<1>	<1>
Logical output 1	<227>	<176>	<1>	<1>
Logical output 2	<227>	<177>	<1>	<1>
Logical output 3	<227>	<178>	<1>	<1>
Logical output 4	<227>	<179>	<1>	<1>
Logical output Watchdog	<227>	<180>	<1>	<1>
Logical output 5	<227>	<181>	<1>	<1>
Logical output 6	<227>	<182>	<1>	<1>
Logical output 7	<227>	<183>	<1>	<1>
Logical output 8	<227>	<184>	<1>	<1>

Supervision Indications				
Description	FUN	INF	TYP	COT
Warning (Minor alarm)	<226>	<46>	<1>	<1>
Group Alarm (Major alarm)	<226>	<47>	<1>	<1>

Alarm Indications				
Description	FUN	INF	TYP	COT
Datation minor alarm	<227>	<193>	<1>	<1>
Backuped RAM minor alarm	<227>	<194>	<1>	<1>
E2PROM Data major alarm	<227>	<200>	<1>	<1>
Analog major alarm	<227>	<201>	<1>	<1>
E2PROM Calibration major alarm	<227>	<202>	<1>	<1>
Default setting major alarm	<227>	<205>	<1>	<1>
Auxiliary power supply	<227>	<207>	<1>	<1>
Transformers offset failure	<227>	<208>	<1>	<1>

Fault Indications (Monitor Direction)				
Description	FUN	INF	TYP	COT
Start Phase A Stage 1	<226>	<64>	<2>	<1>
Start Phase B Stage 1	<226>	<65>	<2>	<1>
Start Phase C Stage 1	<226>	<66>	<2>	<1>
Start Earth Stage 1	<226>	<67>	<2>	<1>
General Trip	<226>	<68>	<2>	<1>
Trip Phase A Stage 1	<226>	<69>	<2>	<1>
Trip Phase B Stage 1	<226>	<70>	<2>	<1>
Trip Phase C Stage 1	<226>	<71>	<2>	<1>
General Start / pick-up	<226>	<84>	<2>	<1>
Breaker failure Stage 1	<226>	<85>	<2>	<1>

Fault Indications (Monitor Direction)				
Description	FUN	INF	TYP	COT
Trip Earth Stage 1	<226>	<92>	<2>	<1>

Fault Indications				
Description	FUN	INF	TYP	COT
Start Dead Zone	<227>	<100>	<2>	<1>
Start Pole Discrepancy	<227>	<101>	<2>	<1>
Trip Dead Zone	<227>	<105>	<2>	<1>
Trip Pole Discrepancy	<227>	<106>	<2>	<1>
Trip Breaker failure Stage 2	<227>	<104>	<2>	<1>
Trip Phase A External	<227>	<107>	<2>	<1>
Trip Phase B External	<227>	<108>	<2>	<1>
Trip Phase C External	<227>	<109>	<2>	<1>
Trip 3 Phase External	<227>	<110>	<2>	<1>
Security 1 Fault	<227>	<122>	<1>	<1>
Security 2 Fault	<227>	<123>	<1>	<1>
Security Conf. error	<227>	<124>	<1>	<1>
CB Opening time Stage 1	<227>	<59>	<2>	<1>
CB Operation nb	<227>	<60>	<2>	<1>
SA2n	<227>	<61>	<2>	<1>
CB Opening time Ext.	<227>	<62>	<2>	<1>
tBF Conf. error	<227>	<127>	<1>	<1>
DZ Conf. error	<227>	<128>	<1>	<1>
PD Conf. error	<227>	<129>	<1>	<1>
Disturbance record. trig	<227>	<3>	<1>	<1> *
IEC103 buffer overflow	<227>	<4>	<2>	<1> *
All Alarms acknowledge (Front panel)	<227>	<52>	<2>	<1> *
First Alarm acknowledge	<227>	<53>	<2>	<1> *
Time Synchronization	<227>	<231>	<1>	<1>
Negative sequence current of CB failure stage 1	<227>	<232>	<2>	<1> *
EVT_PHASE_NON_I_STAGE1	<227>	<233>	<2>	<1> *
EVT_EARTH_NON_I_STAGE1	<227>	<234>	<2>	<1> *
EVT_NEG_NON_I_STAGE1	<227>	<235>	<2>	<1> *
EVT_NON_I_STAGE1	<227>	<236>	<2>	<1> *
EVT_NON_I_STAGE2	<227>	<237>	<2>	<1> *
CB Unhealthy stage 1	<227>	<238>	<2>	<1> *
CB Unhealthy stage 2	<227>	<239>	<2>	<1> *
Boolean Logic Equation A Trip	<227>	<240>	<2>	<1> *
Boolean Logic Equation B Trip	<227>	<241>	<2>	<1> *
Boolean Logic Equation C Trip	<227>	<242>	<2>	<1> *
Boolean Logic Equation D Trip	<227>	<243>	<2>	<1> *
Boolean Logic Equation E Trip	<227>	<244>	<2>	<1> *
Boolean Logic Equation F Trip	<227>	<245>	<2>	<1> *
Boolean Logic Equation G Trip	<227>	<246>	<2>	<1> *

Fault Indications				
Description	FUN	INF	TYP	COT
Boolean Logic Equation H Trip	<227>	<247>	<2>	<1> *

Auto-recloser Indications (monitor direction)				
Description	FUN	INF	TYP	COT
52A (CB in O/O position)	<227>	<125>	<2>	<1>
52B (CB in F/O position)	<227>	<126>	<2>	<1>

Table 35 - List of processed events

3.10.2

System State

List of processed data, following a General interrogation, is given below: it is a sub-assembly of the spontaneous messages.

Status Indications (Monitor Direction)				
Description	FUN	INF	TYP	COT
Local parameter Setting active	<226>	<22>	<1>	<9>
Setting Group number 1 active	<226>	<23>	<1>	<9>
Setting Group number 2 active	<226>	<24>	<1>	<9>
Auxiliary input 1	<226>	<27>	<1>	<9>
Auxiliary input 2	<226>	<28>	<1>	<9>

Supervision Indications				
Description	FUN	INF	TYP	COT
Warning (Minor alarm)	<226>	<46>	<1>	<9>
Group Alarm (Major alarm)	<226>	<47>	<1>	<9>

Logical Statuses				
Description	FUN	INF	TYP	COT
Logical input 1	<227>	<160>	<1>	<9>
Logical input 2	<227>	<161>	<1>	<9>
Logical input 3	<227>	<162>	<1>	<9>
Logical input 4	<227>	<163>	<1>	<9>
Logical input 5	<227>	<164>	<1>	<9>
Logical output 1	<227>	<176>	<1>	<9>
Logical output 2	<227>	<177>	<1>	<9>
Logical output 3	<227>	<178>	<1>	<9>
Logical output 4	<227>	<179>	<1>	<9>
Logical output Watchdog	<227>	<180>	<1>	<9>
Logical output 5	<227>	<181>	<1>	<9>
Logical output 6	<227>	<182>	<1>	<9>
Logical output 7	<227>	<183>	<1>	<9>
Logical output 8	<227>	<184>	<1>	<9>

Fault Indications (monitor direction)				
Description	FUN	INF	TYP	COT
Start Phase A Stage 1	<226>	<64>	<2>	<9>
Start Phase B Stage 1	<226>	<65>	<2>	<9>
Start Phase C Stage 1	<226>	<66>	<2>	<9>
Start Earth Stage 1	<226>	<67>	<2>	<9>
General Start / pick-up	<226>	<84>	<2>	<9>

Fault Indications (control direction)				
Description	FUN	INF	TYP	COT
Start Dead Zone	<227>	<100>	<2>	<9>
Start Pole Discrepancy	<227>	<101>	<2>	<9>
Trip Phase A External	<227>	<107>	<2>	<9>
Trip Phase B External	<227>	<108>	<2>	<9>
Trip Phase C External	<227>	<109>	<2>	<9>
Trip 3 Phase External	<227>	<110>	<2>	<9>

Auto-recloser Indications (monitor direction)				
Description	FUN	INF	TYP	COT
52A (CB in O/O position)	<227>	<125>	<2>	<9>
52B (CB in F/O position)	<227>	<126>	<2>	<9>

Table 36 - List of processed data

3.11 Processed Commands

3.11.1 System Commands

Synchronization Command (ASDU 6):

FUN<226>,INF <255>, TYP <6>, COT<8>

This command can be sent to a specific relay, or global. The time sent by master is the time of the first bit of the frame. The relay synchronizes with this time, corrected by the frame transmission delay. After updating its time, the relay send back an acknowledge to the master, by giving its new current time. This acknowledge message will be an event of ASDU 6 type.

General Interrogation Initialization command (ASDU 7):

FUN<226>,INF <255>, TYP <7>, COT<9>

This command starts the relay interrogation:

The relay then sends a list of data containing the relay state (see list described above).

The GI command contains a scan number which will be included in the answers of the GI cycle generated by the GI command.

If a data has just changed before extracted by the GI, the new state is sent to the master station.

When an event is generated during the GI cycle, the event is sent in priority, and the GI cycle is temporarily interrupted. The end of the GI consists in sending an ASDU 8 to the master station.

If, during a General Interrogation cycle, another GI Initialization command is received, the precedent answer is stopped, and the new GI cycle started.

3.11.2 General Commands (ASDU 20) (Control Direction)

LEDs Reset: This command acknowledges all alarms on Front Panel on P821 products:

FUN<226>,INF<19>,TYP<20>, COT <20>

Setting group number 1: FUN<226>,INF<23>, TYP<20>, COT <20>

Setting group number 2: FUN<226>,INF<24>, TYP<20>, COT <20>

After executing one of these commands, the relay sends an acknowledge message, which contains the result of command execution.

If a state change is the consequence of the command, it must be sent in a ASDU 1 with COT 12 (remote operation).

If the relay receive another command message from the master station before sending the acknowledge message, it will be discarded.

Commands which are not processed by the relay are rejected with a negative acknowledge message.

3.12 Relay Re-Initialization

In case of relay re-initialization, the relay sends to the master station:

Description	FUN	INF	TYP	COT
A message indicating relay start	<226>	<5>	<5>	<5>
or a message indicating Reset CU	<226>	<5>	<3>	<4>
or a message indicating Reset FCB	<226>	<5>	<2>	<3>

Each identification message of the relay (ASDU 5) contains the manufacturer name in 8 ASCII characters et 4 free characters containing: « 821 » (binary) in the first two and the software version in the last two.

Table 37 - Relay re-initialization

3.13 Cyclic Messages (ASDU 9 and ASDU 3)

Only measurands can be stored in these messages.

The measurands values are stored in lower levels of communication, before polling by master station.

Several of the fields in the ASDU 9 (FUN<226>,INF <148>) are unused in the P821 relay (Voltage and Power values), so they are set to 0: Only RMS Ia, Ib, Ic values and frequency are stored (with a rate such as: 2,4 * nominal value = 4096).

In the following ASDU 3 (ASDU 3.4 definition, FUN<226>,INF<147>), only RMS IN value is stored (with a rate such as: 2,4 * nominal value = 4096) (unused VEN value is set to 0).

3.14 IEC870-5-103 Messages for Disturbance Record Extraction

The disturbance extraction procedure with IEC870-5-103 in MICOM Px2x relays is in conformance with IEC870-5-103 standard definition.

The maximum disturbance record number stored in a P821 is 5.

The disturbance record mapping for P821 is the following:

- Number of Analog Channels Transmitted: 4, which are:
 - Channel 1: Ia current (Phase L1).
 - Channel 2: Ib current (Phase L2).
 - Channel 3: Ic current (Phase L3).
 - Channel 4: IN current (Earth).

Identifiers of Tags (15) Transmitted in ASDU 29 (Logical Informations) for P821

Description	FUN	INF
Tag number 1: General start	<226>	<84>
Tag number 2: General Trip	<226>	<68>
Tag number 3: Trip Phase A Stage 1	<226>	<69>
Tag number 4: Trip Phase B Stage 1	<226>	<70>
Tag number 5: Trip Phase C Stage 1	<226>	<71>
Tag number 6: Trip Earth Stage 1	<226>	<92>
Tag number 7: Breaker failure Stage 1	<226>	<85>
Tag number 8: Breaker failure Stage 2	<227>	<104>
Tag number 9: Trip Dead Zone	<227>	<105>
Tag number 10: Trip Pole Discrepancy	<227>	<106>
Tag number 11: Log input 1	<227>	<160>
Tag number 12: Log input 2	<227>	<161>
Tag number 13: Log input 3	<227>	<162>
Tag number 14: Log input 4	<227>	<163>
Tag number 15: Log input 5	<227>	<164>
Tag number 16: negative current stage1	<227>	<232>
Tag number 17: Phase Non I flag	<227>	<233>
Tag number 18: Earth Non I flag	<227>	<234>
Tag number 19: Negative Non I flag	<227>	<235>
Tag number 20: Non I stage 1	<227>	<236>
Tag number 21: Non I stage 2	<227>	<237>
Tag number 22: unhealthy stage 1	<227>	<238>
Tag number 23: unhealthy stage 2	<227>	<239>

Table 38 - Identifiers of tags (15) transmitted in ASDU 29 (logical informations)

4 DNP 3.0 CONFIGURATION/INTEROPERABILITY GUIDE

4.1 Introduction

The purpose of this document is to describe the specific implementation of the Distributed Network Protocol (DNP) 3.0 within P12x.

Px2x uses the Triangle MicroWorks, Inc. DNP 3.0 Slave Source Code Library Version 2.18.

This document, in conjunction with the DNP 3.0 Basic 4 Document Set, and the DNP Subset Definitions Document, provides complete information on how to communicate with P12x via the DNP 3.0 protocol.

This implementation of DNP 3.0 is fully compliant with DNP 3.0 Subset Definition Level 2, contains many Subset Level 3 features, and contains some functionality even beyond Subset Level 3.

4.2 DNP V3.00 Device Profile

Table 39 provides a Device Profile Document in the standard format defined in the DNP 3.0 Subset Definitions Document. While it is referred to in the DNP 3.0 Subset Definitions as a “Document”, it is only a component of a total interoperability guide. In combination with the following, Table 39 should provide a complete interoperability/configuration guide for P12x:

- Implementation Table (Table 40) in Section 4.3 (starting on page 89),
- Point List Table (Table 41) in Section 4.4 (starting on page 93).

DNP V3.00		DEVICE PROFILE DOCUMENT	
(Also see Table 40)		Vendor Name: Schneider Electric	
Device Name: SERIAL 20 Platform using the Triangle MicroWorks, Inc. DNP 3.0 Slave Source			
Code Library, Version 2.18.			
Highest DNP Level Supported:		Device Function:	
For Requests:	Level 2	<input type="checkbox"/> Master	
For Responses:	Level 2	<input checked="" type="checkbox"/> Slave	
<p>Notable objects, functions, and qualifiers supported in addition to the Highest DNP Levels Supported (the complete list is described in this table):</p> <p>For static (non-change-event) object requests, request qualifier codes 00 and 01 (start-stop), 07 and 08 (limited quantity), and 17 and 28 (index) are supported in addition to request qualifier code 06 (no range – or all points).</p> <p>Static object requests received with qualifiers 00, 01, 06, 07, or 08, are responded to with qualifiers 00 or 01. Static object requests received with qualifiers 17 or 28 are responded to with qualifiers 17 or 28.</p> <p>For change-event object requests, qualifiers 17 or 28 are always responded to.</p> <p>16-bit and 32-bit Analog Change Events with Time may be requested.</p> <p>The read function code for Object 50 (Time and Date), variation 1, is supported.</p>			
Maximum Data Link Frame Size (octets):		Maximum Application Fragment Size (octets):	
Transmitted:	292	Transmitted:	2048
Received:	292	Received:	2048
Maximum Data Link Re-tries:		Maximum Application Layer Re-tries:	
<input type="checkbox"/> None		<input checked="" type="checkbox"/> None	
<input checked="" type="checkbox"/> Fixed at 2		<input type="checkbox"/> Configurable	
<input type="checkbox"/> Configurable			
Requires Data Link Layer Confirmation:			
<input checked="" type="checkbox"/>	Never		
	Always		
	Sometimes		
	Configurable		
Requires Application Layer Confirmation:			
	Never		
	Always		
<input checked="" type="checkbox"/>	When reporting Event Data		
<input checked="" type="checkbox"/>	When sending multi-fragment responses		
	Sometimes		
	Configurable		
Timeouts while waiting for:			
Data Link Confirm:	<input type="checkbox"/> None	<input checked="" type="checkbox"/> Fixed at 100 ms	Variable Configurable
Complete Appl. Fragment:	<input checked="" type="checkbox"/> None	Fixed at _____	Variable Configurable
Application Confirm:	<input type="checkbox"/> None	<input checked="" type="checkbox"/> Fixed at 1 s	Variable Configurable
Complete Appl. Response:	<input checked="" type="checkbox"/> None	Fixed at _____	Variable Configurable
Others:			
Binary input change scanning period:	5 ms		
Analog input change scanning period:	1 s		

DNP V3.00 (Also see Table 40)		DEVICE PROFILE DOCUMENT Vendor Name: Schneider Electric			
Sends/Executes Control Operations:					
WRITE Binary Outputs	<input checked="" type="checkbox"/> Never	Always	Sometimes	Configurable	
SELECT/OPERATE	Never	<input checked="" type="checkbox"/> Always	Sometimes	Configurable	
DIRECT OPERATE	Never	<input checked="" type="checkbox"/> Always	Sometimes	Configurable	
DIRECT OPERATE – NO ACK	Never	<input checked="" type="checkbox"/> Always	Sometimes	Configurable	
Count > 1	<input checked="" type="checkbox"/> Never	Always	Sometimes	Configurable	
Pulse On	Never	<input checked="" type="checkbox"/> Always	Sometimes	Configurable	
Pulse Off	<input checked="" type="checkbox"/> Never	Always	Sometimes	Configurable	
Latch On	<input checked="" type="checkbox"/> Never	Always	Sometimes	Configurable	
Latch Off	<input checked="" type="checkbox"/> Never	Always	Sometimes	Configurable	
Queue	<input checked="" type="checkbox"/> Never	Always	Sometimes	Configurable	
Clear Queue	<input checked="" type="checkbox"/> Never	Always	Sometimes	Configurable	
Reports Binary Input Change Events when no specific variation requested:			Reports time-tagged Binary Input Change Events when no specific variation requested:		
<input type="checkbox"/> Never <input checked="" type="checkbox"/> Only time-tagged Configurable			<input checked="" type="checkbox"/> Never <input type="checkbox"/> Binary Input Change With Time <input type="checkbox"/> Binary Input Change With Relative Time Configurable (attach explanation)		
Sends Unsolicited Responses:			Sends Static Data in Unsolicited Responses:		
<input checked="" type="checkbox"/> Never Configurable Only certain objects Sometimes (attach explanation) ENABLE/DISABLE UNSOLICITED Function codes supported			Never When Device Restarts When Status Flags Change No other options are permitted.		
Default Counter Object/Variation:			Counters Roll Over at:		
<input type="checkbox"/> No Counters Reported Configurable <input checked="" type="checkbox"/> Default Object: 20 Default Variation: 5 Point-by-point list attached			<input type="checkbox"/> No Counters Reported Configurable (attach explanation) <input checked="" type="checkbox"/> 16 Bits <input checked="" type="checkbox"/> 32 Bits Other Value: _____ <input checked="" type="checkbox"/> Point-by-point list attached		
Sends Multi-Fragment Responses:					
<input checked="" type="checkbox"/> Yes <input type="checkbox"/> No					

Table 39 - DNP V3.00 - device profile document

4.3 Implementation Table

Table 40 identifies the variations, function codes, and qualifiers supported by the P12x in both request messages and in response messages.

For static (non-change-event) objects, requests sent with qualifiers 00, 01, 06, 07, or 08, are responded to with qualifiers 00 or 01. Static object requests sent with qualifiers 17 or 28 are responded to with qualifiers 17 or 28. For change-event objects, qualifiers 17 or 28 are always responded to.

In Table 40, text shaded as Subset Level 3 indicates Subset Level 3 functionality (beyond Subset Level 2), and text shaded as beyond Subset Level 3 indicates functionality beyond Subset Level 3.

OBJECT			REQUEST (Library will parse)		RESPONSE (Library will respond with)	
Object No	Variation No	Description	Function Codes (dec)	Qualifier Codes (hex)	Function Codes (dec)	Qualifier Codes (hex)
1	0	Binary Input (Variation 0 is used to request default variation)	1 (read)	00, 01 (start-stop) 06 (no range, or all) 07, 08 (limited qty) 17, 28 (index)		
1	1 (default – see Note 1)	Binary Input	1 (read) 22	00, 01 (start-stop) 06 (no range, or all) 07, 08 (limited qty) 17, 28 (index)	129 (response)	00, 01 (start-stop) 17, 28 (index – see Note 2)
2	0	Binary Input Change (Variation 0 is used to request default variation)	1 (read)	06 (no range, or all) 07, 08 (limited qty)		
2	1 (default – see Note 1 for P120 - P121)	Binary Input Change without Time	1 (read)	06 (no range, or all) 07, 08 (limited qty)	129 (response)	17, 28 (index)
2	2 (default – see Note 1)	Binary Input Change with Time	1 (read)	06 (no range, or all) 07, 08 (limited qty)	129 (response)	17, 28 (index)
10	0	Binary Output Status (Variation 0 is used to request default variation)	1 (read)	00, 01 (start-stop) 06 (no range, or all) 07, 08 (limited qty) 17, 28 (index)		
10	2 (default – see Note 1)	Binary Output Status	1 (read)	00, 01 (start-stop) 06 (no range, or all) 07, 08 (limited qty) 17, 28 (index)	129 (response)	00, 01 (start-stop) 17, 28 (index – see Note 2)
12	1	Control Relay Output Block	3 (select) 4 (operate) 5 (direct op) 6 (dir. op, noack)	00, 01 (start-stop) 0 7, 08 (limited qty) 17, 28 (index)	129 (response)	echo of request
20	0	Binary Counter (Variation 0 is used to request default variation)	1 (read) 7 (freeze) 8 (freeze noack) 9 (freeze clear) 10 (frz. cl. noack)	00, 01 (start-stop) 06 (no range, or all) 07, 08 (limited qty) 17, 28 (index)		
20	1	32-Bit Binary Counter	1 (read) 7 (freeze) 8 (freeze noack) 9 (freeze clear) 10 (frz. cl. noack)	00, 01 (start-stop) 06 (no range, or all) 07, 08 (limited qty) 17, 28 (index)	129 (response)	00, 01 (start-stop) 17, 28 (index – see Note 2)
20	2	16-Bit Binary Counter	1 (read) 7 (freeze) 8 (freeze noack) 9 (freeze clear) 10 (frz. cl. noack)	00, 01 (start-stop) 06 (no range, or all) 07, 08 (limited qty) 17, 28 (index)	129 (response)	00, 01 (start-stop) 17, 28 (index – see Note 2)
20	5	32-Bit Binary Counter without Flag	1 (read) 7 (freeze) 8 (freeze noack) 9 (freeze clear) 10 (frz. cl. noack)	00, 01 (start-stop) 06 (no range, or all) 07, 08 (limited qty) 17, 28 (index)	129 (response)	00, 01 (start-stop) 17, 28 (index – see Note 2)

OBJECT			REQUEST (Library will parse)		RESPONSE (Library will respond with)	
Object No	Variation No	Description	Function Codes (dec)	Qualifier Codes (hex)	Function Codes (dec)	Qualifier Codes (hex)
20	6	16-Bit Binary Counter without Flag	1 (read) 7 (freeze) 8 (freeze noack) 9 (freeze clear) 10 (frz. cl. noack)	00, 01 (start-stop) 06 (no range, or all) 07, 08 (limited qty) 17, 28 (index)	129 (response)	00, 01 (start-stop) 17, 28 (index—see Note 2)
21	0	Frozen Counter (Variation 0 is used to request default variation)	1 (read)	00, 01 (start-stop) 06 (no range, or all) 07, 08 (limited qty) 17, 28 (index)		
21	1	32-Bit Frozen Counter	1 (read)	00, 01 (start-stop) 06 (no range, or all) 07, 08 (limited qty) 17, 28 (index)	129 (response)	00, 01 (start-stop) 17, 28 (index—see Note 2)
21	2	16-Bit Frozen Counter	1 (read)	00, 01 (start-stop) 06 (no range, or all) 07, 08 (limited qty) 17, 28 (index)	129 (response)	00, 01 (start-stop) 17, 28 (index—see Note 2)
21	9	32-Bit Frozen Counter without Flag	1 (read)	00, 01 (start-stop) 06 (no range, or all) 07, 08 (limited qty) 17, 28 (index)	129 (response)	00, 01 (start-stop) 17, 28 (index—see Note 2)
21	10	16-Bit Frozen Counter without Flag	1 (read)	00, 01 (start-stop) 06 (no range, or all) 07, 08 (limited qty) 17, 28 (index)	129 (response)	00, 01 (start-stop) 17, 28 (index—see Note 2)
30	0	Analog Input (Variation 0 is used to request default variation)	1 (read)	00, 01 (start-stop) 06 (no range, or all) 07, 08 (limited qty) 17, 28 (index)		
30	1	32-Bit Analog Input	1 (read)	00, 01 (start-stop) 06 (no range, or all) 07, 08 (limited qty) 17, 28 (index)	129 (response)	00, 01 (start-stop) 17, 28 (index—see Note 2)
30	2 (default – see Note 1)	16-Bit Analog Input	1 (read)	00, 01 (start-stop) 06 (no range, or all) 07, 08 (limited qty) 17, 28 (index)	129 (response)	00, 01 (start-stop) 17, 28 (index—see Note 2)
30	3	32-Bit Analog Input without Flag	1 (read)	00, 01 (start-stop) 06 (no range, or all) 07, 08 (limited qty) 17, 28 (index)	129 (response)	00, 01 (start-stop) 17, 28 (index—see Note 2)
30	4	16-Bit Analog Input without Flag	1 (read)	00, 01 (start-stop) 06 (no range, or all) 07, 08 (limited qty) 17, 28 (index)	129 (response)	00, 01 (start-stop) 17, 28 (index—see Note 2)
32	0	Analog Change Event (Variation 0 is used to request default variation)	1 (read)	06 (no range, or all) 07, 08 (limited qty)		
32	1	32-Bit Analog Change Event without Time	1 (read)	06 (no range, or all) 07, 08 (limited qty)	129 (response)	17, 28 (index)
32	2 (default – see Note 1)	16-Bit Analog Change Event without Time	1 (read)	06 (no range, or all) 07, 08 (limited qty)	129 (response)	17, 28 (index)

OBJECT			REQUEST (Library will parse)		RESPONSE (Library will respond with)	
Object No	Variation No	Description	Function Codes (dec)	Qualifier Codes (hex)	Function Codes (dec)	Qualifier Codes (hex)
32	3	32-Bit Analog Change Event with Time	1 (read)	06 (no range, or all) 07, 08 (limited qty)	129 (response)	17, 28 (index)
32	4	16-Bit Analog Change Event with Time	1 (read)	06 (no range, or all) 07, 08 (limited qty)	129 (response)	17, 28 (index)
50	0	Time and Date	1 (read)	00, 01 (start-stop) 06 (no range, or all) 07, 08 (limited qty) 17, 28 (index)	129 (response)	00, 01 (start-stop) 17, 28 (index – see Note 2)
50	1 default – see Note 1)	Time and Date	1 (read) 2 (write)	00, 01 (start-stop) 06 (no range, or all) 07, 08 (limited qty) 17, 28 (index)	129 (response)	00, 01 (start-stop) 17, 28 (index – see Note 2)
52	2	Time Delay Fine			129 (response)	07 (limited qty) (qty = 1)
60	0	Class 0, 1, 2, and 3 Data	1 (read)	06 (no range, or all)		
60	1	Class 0 Data	1 (read)	06 (no range, or all)	129	17,28
60	2	Class 1 Data	1 (read)	06 (no range, or all) 07, 08 (limited qty)	129	17,28
60	3	Class 2 Data	1 (read)	06 (no range, or all) 07, 08 (limited qty)	129	17,28
60	4	Class 3 Data	1 (read)	06 (no range, or all) 07, 08 (limited qty)	129	17,28
80	1	Internal Indications	2 (write)	00 (start-stop) (index must =7)		
No Object (function code only) –See Note 3			13 (cold restart)			
No Object (function code only)			14 (warm restart)			
No Object (function code only)			23 (delay meas.)			
<p><i>Note 1</i> A Default variation refers to the variation responded to when variation 0 is requested or in class 0, 1, 2, or 3 scans.</p>						
<p><i>Note 2</i> For static (non-change-event) objects, qualifiers 17 or 28 are only responded to when a request is sent with qualifiers 17 or 28, respectively. Otherwise, static object requests sent with qualifiers 00, 01, 06, 07, or 08, are responded to with qualifiers 00 or 01. (For change-event objects, qualifiers 17 or 28 are always responded to.)</p>						
<p><i>Note 3</i> For P12x, a cold restart is implemented as a warm restart – the executable is not restarted, but the DNP process is restarted.</p>						

Table 40 - Implementation Table

4.4 Point List

Table 41, Table 42, Table 43 and Table 44 identify all the individual data points provided by this implementation of DNP 3.0. P12x uses the database protection.

4.4.1 Binary Input Points

All Binary Input Status points are included in class 0 polls because they are included in one of classes 1, 2 or 3.

Binary Input Points			
Static (Steady-State) Object Number:		1	
Change Event Object Number:		2	
Request Function Codes supported:		1 (read)	
Static Variation reported when variation 0 requested:		1 (Binary Input without status)	
Change Event Variation reported when variation 0 requested:		2 (Binary Input Change with Time)	
Point Index	Name/Description	init val.	Change Event Class (1, 2, 3 or none)
0	Output relay 1 (trip)	0	1
1	Output relay 2	0	2
2	Output relay 3	0	2
3	Output relay 4	0	2
4	Output relay 0 (watch dog)	0	2
5	Output relay 5	0	2
6	Output relay 6	0	2
7	Output relay 7	0	2
8	Output relay 8	0	2
9	Opto input 1	0	2
10	Opto input 2	0	2
11	Opto input 3	0	2
12	Opto input 4	0	2
13	Opto input 5	0	2
14	Phase A Stage 1 start	0	1
15	Phase A Stage 1 trip	0	1
16	Phase B Stage 1 start	0	1
17	Phase B Stage 1 trip	0	1
18	Phase C Stage 1 start	0	1
19	Phase C Stage 1 trip	0	1
20	BF Stage 1 trip	0	1
21	BF Stage 2 trip	0	1
22	Earth Stage 1 start	0	1
23	Earth Stage 1 trip	0	1
24	Dead Zone start	0	1
25	Dead Zone trip	0	1
26	Pole Discrepancy start	0	1
27	Pole Discrepancy trip	0	1
28	Ph. A external Trip	0	1

Binary Input Points			
Static (Steady-State) Object Number:		1	
Change Event Object Number:		2	
Request Function Codes supported:		1 (read)	
Static Variation reported when variation 0 requested:		1 (Binary Input without status)	
Change Event Variation reported when variation 0 requested:		2 (Binary Input Change with Time)	
Point Index	Name/Description	init val.	Change Event Class (1, 2, 3 or none)
29	Ph. B external Trip	0	1
30	Ph. C external Trip	0	1
31	3 Phase external Trip	0	1
32	tAux1	0	1
33	tAux2	0	1
34	External CB open time alarm	0	1
35	CB open time Stage 1 alarm	0	1
36	CB operation number alarm	0	1
37	SA2n	0	1
38	Setting problem with 50BF	0	1
39	Setting problem with Dead Zone trip	0	1
40	Setting problem with Pole Discrepancy	0	1
41	Setting problem with relay security	0	1
42	Problem with relay security 1	0	1
43	Problem with relay security 2	0	1
44	Security 1 input	0	1
45	Security 2 input	0	1
46	52a	0	1
47	52b	0	1
48	Auxiliary relays unlatch	0	2
49	RL1 (Trip relay) and auxiliary relays unlatch (by Comm.)	0	2
50	RL1 (Trip relay) and auxiliary relays unlatch (by input)	0	2
51	Auxiliary relays latch	0	2
52	Major hardware alarm	0	1
53	Minor hardware alarm	0	1
54	Phase A Stage 1 trip alarm (latched)	0	3
55	Phase B Stage 1 trip alarm (latched)	0	3
56	Phase C Stage 1 trip alarm (latched)	0	3
57	Earth Stage 1 trip alarm (latched)	0	3
58	BF Stage 1 trip alarm (latched)	0	3
59	BF Stage 2 trip alarm (latched)	0	3
60	Setting problem alarm with stage 1 trip (latched)	0	3
61	Relay security 1 alarm (latched)	0	3
62	Relay security 2 alarm (latched)	0	3
63	Setting problem alarm with relay security (latched)	0	3
64	tAux1 alarm (latched)	0	3
65	tAux2 alarm (latched)	0	3
66	Dead Zone start alarm (latched)	0	3

Binary Input Points			
Static (Steady-State) Object Number:		1	
Change Event Object Number:		2	
Request Function Codes supported:		1 (read)	
Static Variation reported when variation 0 requested:		1 (Binary Input without status)	
Change Event Variation reported when variation 0 requested:		2 (Binary Input Change with Time)	
Point Index	Name/Description	init val.	Change Event Class (1, 2, 3 or none)
67	Dead Zone trip alarm (latched)	0	3
68	Setting problem alarm with Dead Zone trip (latched)	0	3
69	Pole Discrepancy start alarm (latched)	0	3
70	Pole Discrepancy trip alarm (latched)	0	3
71	Setting problem alarm with Pole Discrepancy trip (latched)	0	3
72	External CB open time alarm (latched)	0	3
73	CB open time Stage 1 alarm (latched)	0	3
74	CB operation number alarm (latched)	0	3
75	SA2n (latched)	0	3
76	Negative overcurrent start	0	1
77	Negative overcurrent trip	0	1
78	Phase Non I start	0	1
79	Phase Non I trip	0	1
80	Earth Non I start	0	1
81	Earth Non I trip	0	1
82	Negative Non I start	0	1
83	Negative Non I trip	0	1
84	Non I re-trip	0	1
85	Non I back-trip	0	1
86	CB unhealthy re-trip	0	1
87	CB unhealthy back-trip	0	1
88	Logic equation A	0	1
89	Logic equation B	0	1
90	Logic equation C	0	1
91	Logic equation D	0	1
92	Logic equation E	0	1
93	Logic equation F	0	1
94	Logic equation G	0	1
95	Logic equation H	0	1
96	alarm Phase Non I stage1	0	1
97	alarm Earth Non I stage1	0	1
98	alarm Negative Non I stage1	0	1
99	alarm Negative stage1	0	1
100	alarm Equation A	0	1
101	alarm Equation B	0	1
102	alarm Equation C	0	1
103	alarm Equation D	0	1

Binary Input Points			
Static (Steady-State) Object Number:		1	
Change Event Object Number:		2	
Request Function Codes supported:		1 (read)	
Static Variation reported when variation 0 requested:		1 (Binary Input without status)	
Change Event Variation reported when variation 0 requested:		2 (Binary Input Change with Time)	
Point Index	Name/Description	init val.	Change Event Class (1, 2, 3 or none)
104	alarm Equation E	0	1
105	alarm Equation F	0	1
106	alarm Equation G	0	1
107	alarm Equation H	0	1
108	alarm Non I re-trip	0	1
109	alarm Non I back-trip	0	1
110	alarm CB unhealthy re-trip	0	1
111	alarm CB unhealthy back-trip	0	1

Table 41 - Binary Input Points

4.4.2 Binary Output Status Points and Control Relay Output Blocks

Table 42 lists both the Binary Output Status Points (Object 10) and the Control Relay Output Blocks (Object 12).

Binary Output Status points are not included in class 0 polls.

Binary Output Status Points			
Object Number:		10	
Request Function Codes supported:		1 (read)	
Default Variation reported when variation 0 requested:		2 (Binary Output Status)	
Control Relay Output Blocks			
Object Number:		12	
Request Function Codes supported:		3 (select), 4 (operate), 5 (direct operate), 6 (direct operate, Noack)	
Point Index	Name/Description	Initial Status Value	Supported Control Relay Output Block Fields
0	Unlatch of the relays	0	Pulse On
1	First alarm acknowledge	0	Pulse On
2	All alarm acknowledge	0	Pulse On
3	Change of setting group	0	Pulse On
4	RAM hardware alarm acknowledge	0	Pulse On
5	Trip counters reset	0	Pulse On

Table 42 - Binary Output Status Points and Control Relay Output Blocks

4.4.3 Counters

Table 43 lists both Binary Counters (Object 20) and Frozen Counters (Object 21). When a freeze function is performed on a Binary Counter point, the frozen value is available in the corresponding Frozen Counter point.

Binary Counters and Frozen Counters are not included in class 0 polls.

Binary Counters		
Static (Steady-State) Object Number:	20	
Change Event Object Number:	not supported	
Request Function Codes supported:	1 (read), 7 (freeze), 8 (freeze noack), 9 (freeze and clear), 10 (freeze and clear, noack)	
Static Variation reported when variation 0 requested:	5 (32-Bit Binary Counter without Flag)	
Change Event Variation reported when variation 0 requested:	none-not supported	
Frozen Counters		
Static (Steady-State) Object Number:	21	
Change Event Object Number:	not supported	
Request Function Codes supported:	1 (read)	
Static Variation reported when variation 0 requested:	9 (32-Bit Frozen Binary without Flag)	
Change Event Variation reported when variation 0 requested:	none-not supported	
Point Index	Name/Description	Data type
0	3 Phase external Trip number	D2
1	Ph. A external Trip number	D2
2	Ph. B external Trip number	D2
3	Ph. C external Trip number	D2
4	Phase A Stage 1 trip number	D2
5	Phase B Stage 1 trip number	D2
6	Phase C Stage 1 trip number	D2
7	Earth Stage 1 trip number	D2
8	CB Stage 1 trip number	D2
9	CB Stage 2 trip number	D2
10	CB operation number	D2
11	Σ Amps (n) Ia	D3
12	Σ Amps (n) Ib	D3
13	Σ Amps (n) Ic	D3
14	Number of Neg. Retrip	
15	nb_decl_secours_Ext_stage1	
16	nb_decl_secours_Ext_stage2	
17	nb_decl_ext_Non_I	
18	nb_decl_secours_pha_Non_I	
19	nb_decl_secours_terre_Non_I	
20	nb_decl_secours_Neg_Non_I	
21	nb_decl_Non_I_stade2	

Table 43 - Binary Counters

4.4.4 Analog Inputs

Table 44 lists Analog Inputs (Object 30). It is important to note that 16-bit and 32-bit variations of Analog Inputs, Analog Output Control Blocks, and Analog Output Statuses are transmitted through DNP as signed numbers. Even for analog input points that are not valid as negative values, the maximum positive representation is 32767. For each point, the ihScaling and Unitsli column indicates the value of a transmitted 32767. This also implies the value of a transmitted – 32767. The entry in the column does not imply a valid value for the point.

Always indicating the representation of 32767 in Table 44 is a consistent method for representing scale, applicable to all scaling possibilities.

The Default Deadband,In and the Default Change Event Assigned Classl columns are used to represent the absolute amount by which the point must change before an analog change event is generated, and once generated in which class poll (1, 2, 3) the change event will be reported. Only the default values for these columns are documented here because the values may change in operation due to either local (user-interface) or remote (through DNP) control.

All Analog Inputs points are included in class 0 polls, because they are included in one of classes 1, 2 or 3.

Analog Inputs						
Static (Steady-State) Object Number:		30				
Change Event Object Number:		32				
Request Function Codes supported:		1 (read)				
Static Variation reported when variation 0 requested:		2 (16-Bit Analog Input)				
Change Event Variation reported when variation 0 requested:		2 (Analog Change Event w/o Time)				
Change Event Scan Rate:		The scan rate for analog input change events is fixed at 1 s				
Point Index	Name / Description	Initial Value	Scaling and Units (representation of 32767 – see above)	Valid Range	Change Event Dead-band	Initial Change Event Class (1, 2, 3 or none)
0	active group	1	32767	1 ... 2	1	1
1	module IA	0	40 In	0 to 40 In	0.02 In	3
2	module IB	0	40 In	0 to 40 In	0.02 In	3
3	module IC	0	40 In	0 to 40 In	0.02 In	3
4	module IN	0	40 I0n	0 to 40 I0n	0.02 I0n	3
5	rms IA	0A	327.67 A	0 to 40000000 A/100	2%	3
6	rms IB	0A	327.67 A	0 to 40000000 A/100	2%	3
7	rms IC	0A	327.67 A	0 to 40000000 A/100	2%	3
8	rms IN	0A	327.67 A	0 to 40000000 A/100	2%	3
9	frequency	0	327,67 Hz	45Hz to 65 Hz and 99.99 Hz == ERROR	1Hz	3
10	CB operation time	0	327.67s	0 to 10.00 s	10 ms	3
11	Fault Number			1 ... 65535	1	2
12	Active Setting Group			1 ... 2	Each New Fault	2
13	Faulted Phase			0 ... 8	Each New Fault	2

Analog Inputs						
Static (Steady-State) Object Number:				30		
Change Event Object Number:				32		
Request Function Codes supported:				1 (read)		
Static Variation reported when variation 0 requested:				2 (16-Bit Analog Input)		
Change Event Variation reported when variation 0 requested:				2 (Analog Change Event w/o Time)		
Change Event Scan Rate:				The scan rate for analog input change events is fixed at 1 s		
Point Index	Name / Description	Initial Value	Scaling and Units (representation of 32767 – see above)	Valid Range	Change Event Dead-band	Initial Change Event Class (1, 2, 3 or none)
14	Fault Flags			0 ... 19	Each New Fault	2
15	Fault Magnitude			0...40In	Each New Fault	2
16	Fault IA Magnitude			0...40In	Each New Fault	2
17	Fault IB Magnitude			0...40In	Each New Fault	2
18	Fault IC Magnitude			0...40In	Each New Fault	2
19	Fault IC Magnitude			N: 0.1...40 In S: 0.01...8 In VS: 0.002...1 In	Each New Fault	2

Table 44 - Analog Inputs

COMMISSIONING GUIDE

CHAPTER 9

Date (month/year)	02/2016
Software Version	10.E
Hardware Suffix	Phase 2
Serial Number	Hardware installed

CONTENTS

Page (CM) 9-

1	Introduction	5
2	Setting Familiarisation	6
3	Equipment Required for Commissioning	7
3.1	Minimum Equipment Required	7
3.2	Optional Equipment	7
4	Product Checks	8
4.1	With the Relay De-Energised	8
4.1.1	Visual Inspection	8
4.1.2	Insulation	9
4.1.3	External Wiring	9
4.1.4	Watchdog Contacts	10
4.1.5	Auxiliary Supply	10
4.2	With the Relay Energised	11
4.2.1	Watchdog Contacts	11
4.2.2	Date and Time	11
4.2.3	Light Emitting Diodes (LEDs)	11
4.2.4	Opto-Isolated Inputs	11
4.2.5	Output Relays	12
4.2.6	Rear Communications Port	12
4.2.7	Current Inputs	14
5	Setting Checks	15
5.1	Applying the Settings to the Relay	15
5.2	Checking the Relay Settings	15
5.3	Testing "CB Failure protection" and "Dead Zone protection"	16
5.3.1	Wiring diagram	16
5.3.2	MiCOM P821 relay parameters	16
5.3.3	Configuration with 3 Single Currents	17
6	On-Load Checks - Current Input Connections	20
7	Final Checks	21
8	Preventative Maintenance	22
8.1	Maintenance Period	22
8.2	Maintenance Checks	22
8.2.1	Alarms	22
8.2.2	Opto-Isolated Inputs	22
8.2.3	Output Relays	22
8.2.4	Measurement Accuracy	23
8.3	Method of Repair	23

8.3.1	Replacing the Complete Relay	23
8.4	Changing the Battery (For Phase 1 Relays Only)	24
8.4.1	Instructions for Replacing the Battery	24
8.4.2	Post Modification Tests	24
8.4.3	Battery Disposal	24
8.5	Cleaning	24

FIGURES

		Page (CM) 9-
	Figure 1 - Rear terminal blocks on size 20TE case	9

TABLES

		Page (CM) 9-
	Table 1 - Watchdog contact status	10
	Table 2 - Operational range of auxiliary supply	10
	Table 3 - Opto-isolated input terminals	12
	Table 4 - Relay output terminals	12
	Table 5 - RS485 terminals	13
	Table 6 - Current input terminals	14

1 INTRODUCTION

The MiCOM P821 protection relays are fully numerical in their design, implementing many protection and non-protection functions. The relays periodically conduct self-checking and, in the unlikely event of a failure, trigger an alarm. As a result of this, the commissioning tests do not need to be as extensive as with non-numeric electronic or electro-mechanical relays.

To commission numeric relays, it is only necessary to verify that the hardware is functioning correctly and the application-specific software settings have been applied to the relay. It is considered unnecessary to test every function of the relay if the settings have been verified by one of the following methods:

- Extracting the settings applied to the MiCOM relay using appropriate setting software (Preferred method)
- Using the operator interface

To confirm that the product is operating correctly once the application-specific settings have been applied, a test should be performed on a single protection element.

Unless previously agreed to the contrary, the customer is responsible for determining the application-specific settings to be applied to the relay.

The commissioning tests must always be performed in conformance with the rules and regulations of the country of use.

**Caution**

Before carrying out any work on the equipment the user should be familiar with the contents of the Safety Section/Safety Guide SFTY/4LM/D11 or later issue and the ratings on the equipment's rating label.

2 SETTING FAMILIARISATION

When commissioning a MiCOM P821 relay for the first time, sufficient time should be allowed to become familiar with various menus containing the settings.

The User Guide chapter P821/EN FT gives a detailed description of the menu structures for the MiCOM P821 relay.

With the plastic front cover in place, all keys except the  key are accessible. All menu cells can be read. LEDs and alarms can be reset. However, no protection or configuration settings can be changed.

Removing the cover allows access to all keys so that settings can be changed. However, certain settings with protected access will require the appropriate password to be entered before changes can be made.

Alternatively, using a PC with MiCOM S1 Studio setting software, the settings can be viewed one page at a time and printed. This software also allows settings to be entered more easily, saved for future reference or printed to produce a setting record.

3 EQUIPMENT REQUIRED FOR COMMISSIONING

3.1 Minimum Equipment Required

Voltmeter test set with chronometer (range: 0 to 240 VAC).

Supply voltage of 48-125 VDC or 220 VAC.

Multimeter with suitable AC current range, and AC/DC voltage ranges of 0 to 250 V respectively.

Continuity tester (if not included in multimeter).

Phasemeter.

Indicates the order of succession of phases.

Note Modern test equipment may contain many of the above features in one unit.

3.2 Optional Equipment

Multi-finger test plug type MMLB01 (if test block type MMLG installed).

An electronic or brushless insulation tester with a dc output not exceeding 500 V (for insulation resistance testing when required).

A PC, with appropriate software (this enables the rear communications port to be tested, if this is to be used, and will also save considerable time during commissioning).

KITZ K-Bus to RS232 protocol converter (if RS485 K-Bus port is being tested and one is not already installed).

RS485 to RS232 converter (if RS485 Modbus port is being tested). Part numbers RS-CONV1 or RS-CONV32 (please contact us for more information).

A printer (to printing a setting record from the PC).

4 PRODUCT CHECKS

These product checks cover all aspects of the relay to ensure that it has not been physically damaged before commissioning, is functioning correctly and all input quantity measurements are within the stated tolerances.

If the application-specific settings have been downloaded to the relay before commissioning, make a backup copy of the settings so they can be restored later. Use one of the following methods.

- Obtain a setting file from the customer (this requires a PC with MiCOM S1 Studio setting software).
- Extract the settings from the relay (this requires a PC with MiCOM S1 Studio setting software).
- Manually create a settings record.

If password protection is enabled, the customer may have changed the password to prevent changes to some of the settings. In this case, either the revised password should be provided or the customer should restore the original password before testing.

<i>Note</i>	<i>In the event that the password has been lost, a recovery password can be obtained from Schneider Electric by quoting the serial number of the relay.</i>
-------------	-------------------------------------------------------------------------------------------------------------------------------------------------------------

4.1 With the Relay De-Energised



Caution	Risk of electric shock. Before performing the following group of tests, disconnect the auxiliary supply from the relay and isolate the trip circuit.
----------------	-------------------------------------------------------------------------------------------------------------------------------------------------------------

The current transformer connections must be isolated from the relay for these checks. If an MMLG test block is provided, the required isolation can easily be achieved by inserting test plug type MMLB01 which effectively open-circuits all wiring routed through the test block.

Before inserting the test plug, refer to the scheme (wiring) diagram to ensure that this will not create a safety hazard or cause damage.

If a test block is not provided, the current transformer supply to the relay should be isolated using the panel links or connecting blocks. If means of isolating the auxiliary supply and trip circuit are provided (such as isolation links, fuses, MCB), these should be used. If this is not possible, the wiring to these circuits must be disconnected and the exposed ends suitably terminated to prevent them from being a safety hazard.

4.1.1 Visual Inspection

Carefully examine the relay to make sure that no physical damage has occurred since installation.

Check the rating information under the top cover on the front of the relay to ensure that it is correct for the particular installation.

The case earth connector is at the rear of the relay in the upper right-hand corner. Connect this to a local earth bar using an adequate conductor, minimum size 1.5 mm².

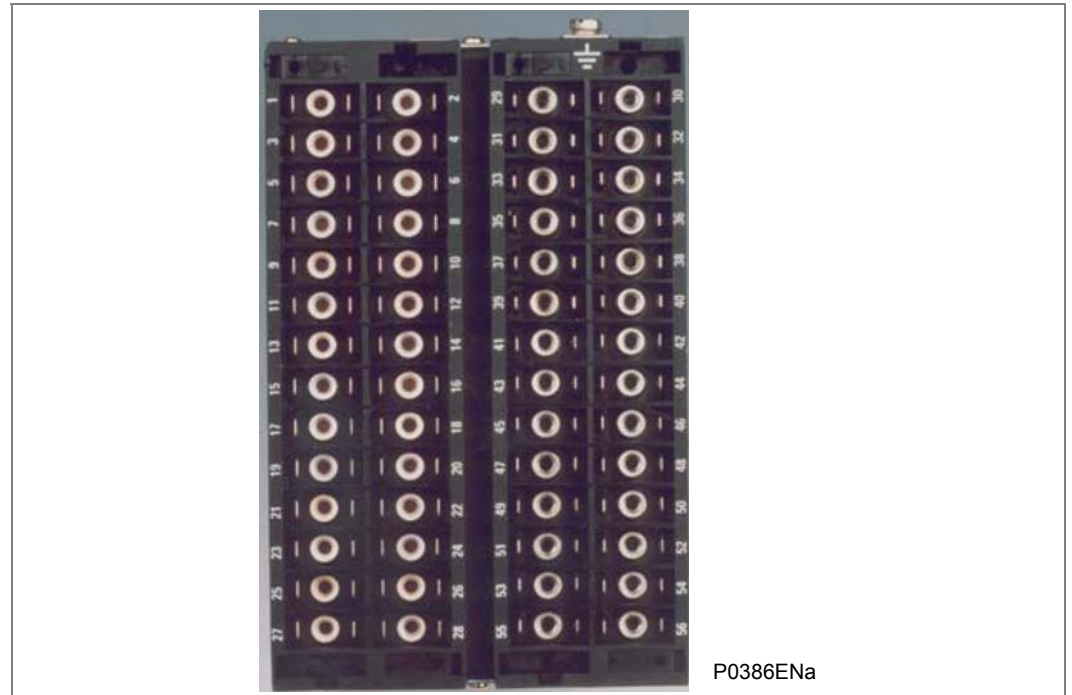

Figure 1 - Rear terminal blocks on size 20TE case

4.1.2

Insulation

Insulation resistance tests are only necessary during commissioning if they haven't been performed during installation.

Isolate all wiring from the earth and test the insulation with an electronic insulation tester at a DC voltage not exceeding 500 V. Terminals of the same circuits should be temporarily connected together.

The main groups of relay terminals are:

- a. Current transformer circuits.
- b. Auxiliary voltage supply.
- c. External voltage output and opto-isolated inputs.
- d. Relay contacts.
- e. RS485 communication port.
- f. Case earth.

The insulation resistance should be greater than 100 M Ω at 500 V.

Caution **When the insulation resistance tests are complete, ensure all external wiring is correctly reconnected to the relay.**

4.1.3

External Wiring

Check that the external wiring is correct to the relevant connection diagram or scheme diagram.

If an MMLG test block is provided, the connections should be checked against the scheme (wiring) diagram. Connect the supply to the live side of the test block, coloured orange with terminals numbered 1, 3, 5, 7 etc.. Connect the auxiliary power supply to terminals 13 (supply positive) and 15 (supply negative). Connect the relay's supply terminals to terminals 14 (relay positive) and 16 (relay negative). Check the wiring against the schematic diagram for the installation to ensure compliance with the customer's normal practice.

4.1.4 Watchdog Contacts

Using a continuity tester, check that the normally closed watchdog contacts are in the states given in Table 1 for a de-energised relay.

Terminals	Watchdog contacts	
	Relay de-energised	Relay energised
35-36	Closed	Open
36-37	Open	Closed

Table 1 - Watchdog contact status

4.1.5 Auxiliary Supply

The relay can be operated from either a DC only or an AC/DC auxiliary supply depending on the relay's nominal supply rating. The voltage must be within the operating range specified in Table 2.

Without energising the relay, measure the auxiliary supply to ensure it is within the operating range.

Nominal supply rating		DC operating range	AC operating range
DC	[AC RMS]		
24-60 Vdc	[-]	19 to 72 V	-
48-150 Vdc	[-]	38.4 to 180 V	
24-250 Vdc 24- 240 Vac	[19.2-250 V]	24-250 Vdc 24- 240 Vac	[19.2-250 V]

Table 2 - Operational range of auxiliary supply

The relay can withstand an AC ripple of up to 12 % of the upper rated voltage on the DC auxiliary supply.



Caution Risk of equipment damage. Do not energize the relay Using the battery charger with the battery disconnected. this can irreparably damage the relay's power supply circuitry.



Caution Energize the relay if the auxiliary supply is within the operating range. If an MMLG test block is provided, it may be necessary to link across the front of the test plug to connect the auxiliary supply to the relay.

4.2 With the Relay Energised



Caution Risk of electric shock. The following group of tests should be carried out with the auxiliary supply applied to the relay. They are used to verify that the relay hardware and software are functioning correctly. The current transformer connections must remain isolated from the relay for these checks.

4.2.1 Watchdog Contacts

Using a continuity tester, check the watchdog contacts are in the states given in Table 1 for an energised relay.

4.2.2 Date and Time

Set the date and time to the correct values. Refer to Chapter P821/EN FT of the Technical guide.

4.2.3 Light Emitting Diodes (LEDs)

On power-up the green Light Emitting Diode (LED) should switch on and stay on, indicating that the relay is healthy. The relay's non-volatile memory stores the state (on or off) of the alarm and trip LEDs when the relay was last energised from an auxiliary supply. Therefore these LEDs may also switch on when the auxiliary supply is applied.

If any of these LEDs are on, reset them before proceeding with further testing. If the LEDs switch off, they have been successfully reset and are working correctly. If any of the LEDs do not switch off, testing is required.

4.2.3.1 Testing the Alarm LED

This is checked during the setting tests.

4.2.3.2 Testing the Trip LED

This is checked during the setting tests.

4.2.3.3 Testing the User-Programmable LEDs

This is checked during the setting tests.

4.2.4 Opto-Isolated Inputs

This test checks that all the opto-isolated inputs on the relay are functioning correctly. (five opto-isolated inputs for the P821).

The opto-isolated inputs should be energised one at a time. Ensuring correct polarity, connect the auxiliary voltage to the appropriate terminals for the input being tested. The opto-isolated input terminal allocations are shown in Table 3.

Select **OP. PARAMETERS** then **INPUTS** to view the state of each input. A '1' indicates an energised input and a '0' indicates a de-energised input. When each input is energised, one of the digits on the bottom line of the display changes to the value shown in Table 3 to indicate the new state of the inputs.

Inputs	Apply a continuous current across terminals		Inputs				
	Negative	Positive					
Opto input 1	24	22	0	0	0	0	1
Opto input 2	28	26	0	0	0	1	0
Opto input 3	19	17	0	0	1	0	0
Opto input 4	23	21	0	1	0	0	0
Opto input 5	27	25	1	0	0	0	0

Table 3 - Opto-isolated input terminals

4.2.5

Output Relays

This test checks that all the output relays are functioning correctly. (8 output relays for the P821).

Energise the output relays one at a time.

Connect a continuity tester across the terminals for output relay 1 in Table 4.

Select OP PARAMETERS then Relay Status.

Relay	8	7	6	5	4	3	2	1
Status	0	0	0	0	0	0	0	1

Repeat the test for each relay.

If the continuity tester operates for a normally open contact and does not operate for a normally closed contact, the relay is functioning correctly.

Note Ensure that thermal ratings of anything connected to the output relays during the test procedure are not exceeded, caused by the associated output relay being operated for too long. Keep the time between application and removal of relay testing to the minimum.

Output relays	Monitor terminals		Output relays states							
	N/C	N/O	8	7	6	5	4	3	2	1
Relay 1	2-4	2-6	0	0	0	0	0	0	0	1
Relay 2	8-10	8-12	0	0	0	0	0	0	1	0
Relay 3	-	14-16	0	0	0	0	0	1	0	0
Relay 4	-	18-20	0	0	0	0	1	0	0	0
Relay 5	-	1-3	0	0	0	1	0	0	0	0
Relay 6	-	5-7	0	0	1	0	0	0	0	0
Relay 7	-	9-11	0	1	0	0	0	0	0	0
Relay 8	-	13-15	1	0	0	0	0	0	0	0

Table 4 - Relay output terminals

4.2.6

Rear Communications Port

This test should only be performed where the relay is to be accessed from a remote location and varies depending on the communications standard being adopted.

The test is not intended to verify the operation of the complete system from the relay to the remote control centre, just the relay's rear communications port and any protocol converter necessary.

On the relay front panel under the top cover there is a label showing the protocol available for remote communication.

4.2.6.1**Courier Communications**

If a K-Bus to RS232 KITZ protocol converter is installed, connect a PC running the appropriate software to the incoming (remote from relay) side of the protocol converter.

If a KITZ protocol converter is not installed, it may not be possible to connect the PC to the type installed. In this case a KITZ protocol converter and PC running the appropriate software should be temporarily connected to the relay's K-Bus port. The terminal numbers for the relay's K-Bus port are shown in Table 5. However, as the installed protocol converter is not being used in the test, only the correct operation of the relay's K-Bus port will be confirmed.

Connection		Terminal
KBUS	Modbus or VDEW	
Screen	Screen	29
1	Negative	31
2	positive	32

Table 5 - RS485 terminals

In the **COMMUNICATIONS** menu, set the relay's Courier address between 1 and 255.

Check that communications can be established with this relay using the PC.

4.2.6.2**Modbus Communications**

Connect a PC (master station) running the appropriate Modbus Master Station software to the relay's RS485 port via a RS485 to RS232 interface converter. The terminal numbers for the relay's RS485 port are shown in Table 5.

Ensure that the relay address, baud rate and parity settings in the Modbus software are set the same as on the MiCOM relay (see the COMMUNICATIONS menu).

Check that communications with this relay can be established.

4.2.6.3**IEC60870-5-103 (VDEW) Communications**

IEC60870-5-103/VDEW communication systems are designed to have a local Master Station. Use this to verify that the relay's fibre optic or RS485 port is working.

Ensure that the relay address, baud rate and parity settings in the Master Station software are set the same as on the MiCOM relay (see the COMMUNICATIONS menu).

Using the Master Station, check that communications with the relay can be established.

4.2.7

Current Inputs

This test verifies the accuracy of current measurement is within the acceptable tolerances.

Three types of connection for the MiCOM P821 are possible.



Caution **The following tests are performed with a phase-phase connection corresponding to the most frequent configuration.**

Apply the rated current to each current input. Check its magnitude using a multimeter. Refer to Table 6 for the corresponding reading in the relay's MEASUREMENTS menu and record the value displayed.

MEASUREMENTS menu	Current applied to
IA 5A (RMS value)	41-42
IB 5A (RMS value)	43-44
IC 5A (RMS value)	45-46
IN 5A (RMS value)	47-48
IA 1A (RMS value)	49-50
IB 1A (RMS value)	51-52
IC 1A (RMS value)	53-54
IN 1A (RMS value)	55-56

Table 6 - Current input terminals

The measured current values on the relay are in primary Amps.

The measurement accuracy of the relay is $\pm 1\%$. However, additional allowance must be made for the accuracy of the test equipment being used.

5 SETTING CHECKS

The setting checks ensure that all of the relay's protection and control settings and programmable logic equations for the particular installation have been correctly applied to the relay.

5.1 Applying the Settings to the Relay

There are two methods of applying the settings:

- Transfer the settings from a pre-prepared setting file to the relay using a PC running the appropriate software. Connect the PC to the relay's front RS232 port under the bottom cover or to the rear communications port. This is the preferred method for transferring function settings as it is much faster and there is less margin for error.

<i>Note</i>	<i>If a setting file has been created for the particular application and provided on a portable data storage medium, this will further reduce the commissioning time.</i>
-------------	---------------------------------------------------------------------------------------------------------------------------------------------------------------------------

- Enter them manually using the relay's operator interface.

5.2 Checking the Relay Settings

Carefully check the settings applied to the relay to ensure they have been entered correctly.

There are two methods of checking the settings:

- Extract the settings from the relay using a PC running the appropriate software via the front RS232 port, under the bottom cover, or via the rear communications port:
 - with a KITZ protocol converter connected if the rear protocol is Kbus,
 - with a standard RS232/RS485 converter if the rear protocol is Modbus.
- If the customer has only provided a printed copy of the required settings and a PC is available, compare the settings taken from the relay with the original application-specific settings.
- Step through the settings using the relay's operator interface and compare them with the original settings.

5.3 Testing "CB Failure protection" and "Dead Zone protection"

5.3.1 Wiring diagram

Refer to the connection diagram in the P821_ENCO.

5.3.2 MiCOM P821 relay parameters

5.3.2.1 CB Failure (50BF)

Note the settings of the MiCOM P821 relays are by default the following:

$I_{>BF} = 0,10 I_n$

Delay stage 1 = $t_{BF1} = 10 \text{ ms}$

Delay stage 2 = $t_{BF2} = 40 \text{ ms}$

Change the settings of the MiCOM P821.

For example for a line feeder:

$I_{>BF} = 0,20 I_n$

Delay stage 1 = $t_{BF1} = 0 \text{ ms}$

therefore retrip after 20 ms*

Delay stage 2 = $t_{BF2} = 130 \text{ ms}$

therefore backtrip after 150 ms*

For example for a generator feeder:

$I_{>BF} = 0,05 I_n$

Delay stage 1 = $t_{BF1} = 0 \text{ ms}$

therefore retrip after 20 ms*

Delay stage 2 = $t_{BF2} = 130 \text{ ms}$

therefore backtrip after 150 ms*

* The time delay does not take into account the opto-coupler input filtering and processing which is $20 \text{ ms} \pm 1 \text{ ms}$.

5.3.2.2 Dead Zone (DBI)

Note the settings of the MiCOM P821 relays are by default the following:

$I_{DZ} = 1,00 I_n$

$t_{DZ} = 10 \text{ ms}$

Change the settings of the MiCOM P821.

5.3.3 Configuration with 3 Single Currents

5.3.3.1 Breaker Failure Protection

Values to be measured:

$I_{>BF} = 0.20 I_n$

Delay stage 1 = $t_{BF1} = 0$ ms thus retrip after 20 ms*

Delay stage 2 = $t_{BF2} = 130$ ms thus backtrip after 150 ms*

***I*>BF Check**

1. Energise a trip order input (A, then B, then C, then 3 phase)
2. Gradually inject the current into the 3 phases up to the stage value: retripping of the tripped phase (A, then B, then C, then A, B and C) should occur for a current equal to the stage ($I_{>BF}$) to within $\pm 2\%$ followed by the backtrip

Action check:

1. Appearance of an alarm message on the display
2. Flashing of the Alarm LED
3. Illumination of the Trip LED if tripping is programmed
4. Illumination of the LEDs associated with instantaneous information 50BF if programmed
5. Trip relay operation (RL1, 2 and 3) if programmed (phase A, B and C)
6. Trip relay operation (RL4) if programmed (Backtrip)

***t*BF1 and not *t*BF2**

7. Inject the current $1.00 I_n$ into the 3 phases
8. Energise the trip order input
9. Before BF2 cut the current injection, the retrip of the tripped phase (A or B or C) should occur at $t_{BF1} + 20$ ms and no backtrip shall follow

Action check:

1. Appearance of an alarm message on the display
2. Flashing of the Alarm LED
3. Illumination of the Trip LED if tripping is programmed
4. Illumination of the LEDs associated with instantaneous information 50BF if programmed
5. Trip relay operation (RL1, 2 and 3) if programmed (phase A, B and C)
6. Trip relay NO operation (RL4) if programmed (Backtrip)

tBF1 and tBF2

1. Inject the current 1.00 In into the 3 phases
2. Energise the trip order input
3. After $tBF2 + 10$ ms (or more) cut the current injection, the retrip of the tripped phase (A or B or C) should occur at $tBF1+20$ ms and followed by the backtrip at $tBF2+20$ ms

Action check:

1. Appearance of an alarm message on the display
2. Flashing of the Alarm LED
3. Illumination of the Trip LED if tripping is programmed
4. Illumination of the LEDs associated with instantaneous information 50BF if programmed
5. Trip relay operation (RL1, 2 and 3) if programmed (phase A, B and C)
6. Trip relay operation (RL4) if programmed (Backtrip)

5.3.3.2**Dead Zone Protection****Values to be measured:**

$I_{DZ} > = 1.2 I_n$

$t_{DZ} = 10$ ms

I_{DZ} Check

1. Energise the 52b input
2. Gradually inject the current into the 3 phases up to the stage value: tripping of the Dead Zone relay (and/or three phase (A or B or C)) should occur for a current equal to the stage (I_{DZ}) to within $\pm 2\%$.

Action check:

1. Appearance of an alarm message on the display
2. Flashing of the Alarm LED
3. Illumination of the Trip LED if tripping is programmed
4. Illumination of the LEDs associated with instantaneous information DZ if programmed
5. Trip relay operation (RL1, 2, and 5) if programmed (phase A, B, C and Intertrip signalling)

***t* DZ Check**

1. Energise the 52b input
2. Inject 1.5 In A current into the 3 phases: tripping of the Dead Zone relay (and/or three phase (A or B or C)) should occur after $t_{DZ}+20$ ms.

Action check:

1. Appearance of an alarm message on the display
2. Flashing of the Alarm LED
3. Illumination of the Trip LED if tripping is programmed
4. Illumination of the LEDs associated with instantaneous information DZ if programmed
5. Trip relay operation (RL1, 2, and 5) if programmed (phase A, B, C and Intertrip signalling)

6 ON-LOAD CHECKS - CURRENT INPUT CONNECTIONS

The following on-load measuring checks ensure the external wiring to the current inputs is correct. However, they can only be carried out if there are no restrictions preventing the energisation of the plant being protected.



Caution Remove all test leads, temporary shorting leads, etc. and replace any external wiring that has been removed to allow testing.

Caution If it has been necessary to disconnect any of the external wiring from the relay to perform any of the foregoing tests, ensure that all connections are replaced in accordance with the relevant external connection or scheme diagram.



Caution Using a multimeter, measure the current transformer secondary currents to ensure they are correctly rated. Check that the system phase order is correct using a phase meter.

Caution Compare the values of the secondary phase currents with the relay's measured values, which can be found in the measurements menu.

The values measured by the MiCOM relay should be within 1% of the applied primary currents. However, an additional allowance must be made for the accuracy of the test equipment being used.

7 FINAL CHECKS

The tests are now complete.



Caution Remove all test or temporary shorting leads, etc. If it has been necessary to disconnect any of the external wiring from the relay to perform the wiring verification tests, ensure that all connections are replaced in accordance with the relevant external connection or scheme diagram.

If the relay is in a new installation or the circuit breaker has just been maintained, the circuit breaker maintenance counters should be reset to zero. To do this, go to the "**RECORDS/CB MONITORING**" menu.

If an MMLG test block is installed, remove the MMLB01 test plug and replace the MMLG cover so that the protection is put into service.

Ensure that all event records, fault records, disturbance records, alarms and LEDs are reset before leaving the relay.

If applicable, replace the secondary front cover on the relay.

8 PREVENTATIVE MAINTENANCE

8.1 Maintenance Period

It is recommended that products supplied by Schneider Electric receive periodic monitoring after installation. As with all products some deterioration with time is inevitable. In view of the critical nature of protective relays and their infrequent operation, it is desirable to confirm that they are operating correctly at regular intervals.

Schneider Electric protective relays are designed for a life in excess of 20 years.

The MiCOM P821 protection relays are self-checking. They therefore require less maintenance than models using earlier technologies. Most problems will result in an alarm so that remedial action can be taken. However, some periodic tests should be done to ensure that the relay is functioning correctly and the external wiring is intact.

If a preventative maintenance policy exists in the customer's organisation, the recommended product checks should be included in the regular programme. Maintenance periods will depend on many factors, such as:

- the operating environment
- accessibility of the site
- amount of available manpower
- importance of the installation in the power system
- consequences of failure

8.2 Maintenance Checks

Some functionality checks can be performed from a remote location using the communications ability of the relays. However, these are mainly restricted to checking the relay is measuring the applied currents accurately, and checking the circuit breaker maintenance counters. Therefore it is recommended that maintenance checks are performed locally (at the substation).



Caution Before carrying out any work on the equipment the user should be familiar with the contents of the Safety Section/Safety Guide SFTY/4LM/D11 or later issue and the ratings on the equipment's rating label.

8.2.1 Alarms

Check the alarm status LED to see if any alarm conditions exist. If so, press the read key (Ⓜ) repeatedly to display the alarms individually. Clear the alarms (key Ⓞ) to switch the LED off.

8.2.2 Opto-Isolated Inputs

Check the opto-isolated inputs to ensure that the relay responds to their energisation by repeating the commissioning test in section 4.2.4 of this chapter.

8.2.3 Output Relays

Check the output relays to ensure that they operate by repeating the commissioning test in section 4.2.5 of this chapter.

8.2.4 Measurement Accuracy

If the power system is energised, the values measured by the relay can be compared with known system values to check they are in the expected range. If they are in the expected range, the analogue to digital conversion and calculations are being performed correctly by the relay. Suitable test methods are described in section 6 of this chapter.

Alternatively, the values measured by the relay can be checked against known values injected into the relay via the test block, if fitted, or injected directly into the relay terminals. Suitable test methods are described in section 7 of this chapter. These tests will prove the calibration accuracy is being maintained.

8.3 Method of Repair

If the relay develops a fault while energised, depending on the nature of the fault, the watchdog contacts change state and an alarm is generated. Due to the use of surface-mount components, faulty PCBs should be replaced as it is not possible to perform repairs on damaged circuits. The complete relay can be replaced or just the faulty PCB identified by the relay's diagnostic software. Refer to Chapter P821/EN FT of this Technical Guide for more information on alarms.

The preferred method is to replace the complete relay. This ensures that the internal circuitry is protected against electrostatic discharge and physical damage at all times, and overcomes the possibility of incompatibility between replacement PCBs. However, it may be difficult to remove an installed relay due to limited access in the back of the cubicle and rigidity of the scheme wiring. To avoid such difficulties the MiCOM P821 relays are designed to be removed while energised for fast replacement of the live part of the relay, minimising the absence of protection.

**Caution**

Before carrying out any work on the equipment you should be familiar with the contents of the safety information chapter/safety guide SFTY/4LM/D11 or later issue and the ratings on the equipments rating label. This should ensure that no damage is caused by incorrect handling of the electronic components.

8.3.1 Replacing the Complete Relay

The MiCOM P821 relays can be removed and replaced if necessary without having to disconnect the rear terminals.

This is possible while the relay is energised. However, it is recommended that all auxiliary supplies are isolated before working on the relay.

8.4 Changing the Battery (For Phase 1 Relays Only)

Phase 2 relays do not use a battery.

Each Phase 1 relay has a battery to maintain data in case the auxiliary supply fails. The data maintained includes event, fault and disturbance records at the correct time of failure.

This battery periodically needs changing, although an alarm is given if the battery is low.

8.4.1 Instructions for Replacing the Battery

Open the bottom cover on the front of the relay.

Carefully extract the battery from its socket. If necessary, use a small screwdriver to prize the battery free.

Ensure that the metal terminals in the battery socket are free from corrosion, grease and dust.

Fit the replacement battery into the battery socket, ensuring the correct polarity.

Note Only use a 3.7 V ½AA Lithium battery.



Caution Ensure that the battery is secure in its socket and that the terminals are making good contact.

Close the bottom cover on the front of the relay.

8.4.2 Post Modification Tests

To check that the replacement battery will maintain the date and time if the auxiliary supply fails, change the date and time on the relay, then disconnect and reconnect the auxiliary supply. The date and time should be maintained.

8.4.3 Battery Disposal

The battery that has been removed should be disposed of in accordance with the disposal procedure for Lithium batteries in the country in which the relay is installed.

8.5 Cleaning

Before cleaning the equipment, isolate all inputs to prevent any risk of electric shock.

Clean the equipment using a clean, damp cloth. Do not use detergents, solvents or abrasive cleaners as they may damage the relay's surface and leave a conductive residue.

VERSION HISTORY

CHAPTER 10

Date (month/year)	02/2016
Software Version	10.E
Hardware Suffix	Phase 2
Serial Number	Hardware installed

CONTENTS

Page (VC) 10-

1	Software Version History P821	5
---	-------------------------------	---

TABLES

Page (VC) 10-

	Table 1 – Software version history	6
--	------------------------------------	---

Notes:

1 SOFTWARE VERSION HISTORY P821

Software Version	Date of Issue	Full Description of Changes	S1 Compatibility	Backward Compatibility with previous hardware
V1.A	05/04/2004	First issue	V2.09	HARD V 4
V1.B	07/01/2005	S/W Enhancements Included: <ul style="list-style-type: none"> • Clear push button management and change setting group management. S/W Corrections Included: <ul style="list-style-type: none"> • FPGA Load feature. • Front panel MODBUS broadcast address added • One sample shift between analogue and logic sample in disturbance recorder fixed. • Dynamic address change for DNP3 added. • Shift of front panel relay setting in wiring security function. 	V2.10	HARD V 4
V1.C	28/02/2006	S/W Enhancements Included <ul style="list-style-type: none"> • MiCOM P821 for EA S/W Corrections Included: <ul style="list-style-type: none"> • The scale factor RFA of IEC870-5-103 upload corrected 	V2.10	HARD V 4
V1.D	06/03/2008	S/W Enhancements Included <ul style="list-style-type: none"> • Increase of Event records capacity from 75 to 150 Add fault record implementation in DNP3 communication <ul style="list-style-type: none"> • S/W Corrections Included: • Stability against walk-talker and switch on/off the power supply • English text is improved • Date and time synchronization message sent to relay address in Courier communication is corrected • Modbus front port address > 255 can operate now • Courier rear port, extraction of disturbance, the amplitude is corrected • Correct the processing of "Major Hardware Alarm" and "Minor hardware alarm" by DNP3 • The default address with Courier is 255, not 1. • Risk of inconsistency between the content of a backup SRAM zone and the corresponding checksum after an update • Error in Modbus address for events "Pole Discrepancy Start/trip", "End fault function Start/trip", and CB Supervision events 	V2.14	HARD V 4

Software Version	Date of Issue	Full Description of Changes	S1 Compatibility	Backward Compatibility with previous hardware
V1.E	26/02/2009	S/W Corrections Included: <ul style="list-style-type: none"> A "RAM Error" alarm appears (when battery alarm is set to "Yes"), and all defaults are reset after a power off/on of the relay 	S1 Studio	HARD V 4
V1.F	08/09/2009	S/W Corrections Included: <ul style="list-style-type: none"> CBF Earth Fault element mal-operate when single phase trip command is started 	S1 Studio	HARD V 4
V10.A		Upgrade to Px20 platform. Software enhancements include: <ul style="list-style-type: none"> Enhanced features for Breaker Fail, Dead Zone Add Blocking Logic Add Boolean Equations 	S1 Studio	Phase 2
V10.B	03/2012	Upgrade BIOS from A1.31 to A1.33	S1 Studio	Phase 2
V10.C	03/2012	Upgrade BIOS from A1.33 to A1.34 New alarm indications for: <ul style="list-style-type: none"> Loss of Mains Power Supply Loss of Auxiliary Power Supply Transformer Offsets 	S1 Studio	Phase 2
V10.D	04/2014	Upgrades BIOS from A1.34 to A1.36	S1 Studio	Phase 2
V10.E	02/2016	Software corrections include: <ul style="list-style-type: none"> Fixed the event record function in the IEC 103 protocol constantly generate the event "local mode" every 5mins Correction the SW version indication in menu 	S1 Studio	Phase 2

Table 1 – Software version history

SYMBOLS AND GLOSSARY

CHAPTER SG

CONTENTS

Page SG-

1	Acronyms and Abbreviations	5
2	Company Proprietary Terms	12
3	ANSI Terms	13
4	Concatenated Terms	17
5	Units for Digital Communications	18
6	American vs British English Terminology	19
7	Logic Symbols and Terms	20
8	Logic Timers	25
9	Logic Gates	27

TABLES

Page SG-

Table 1 - Acronyms and abbreviations	11
Table 2 - Company-proprietary terms	12
Table 3 - ANSI abbreviations	13
Table 4 - ANSI descriptions	16
Table 5 - Concatenated terms	17
Table 6 - Units for digital communications	18
Table 7 - American vs British English terminology	19
Table 8 - Logic Symbols and Terms	24
Table 9 - Logic Timers	26

FIGURES

Page SG-

Figure 1 - Logic Gates	27
-------------------------------	-----------

Notes:

1 ACRONYMS AND ABBREVIATIONS

Term	Description
<	Less than: Used to indicate an “under” threshold, such as undercurrent (current dropout).
>	Greater than: Used to indicate an “over” threshold, such as overcurrent (current overload)
A	Ampere
AA	Application Association
AC / ac	Alternating Current
ACSI	Abstract Communication Service Interface
ACSR	Aluminum Conductor Steel Reinforced
ALF	Accuracy Limit Factor
AM	Amplitude Modulation
ANSI	American National Standards Institute
AR	Auto-Reclose.
ARIP	Auto-Reclose In Progress
ASCII	American Standard Code for Information Interchange
ATEX	ATEX is the Potentially Explosive Atmospheres directive 94/9/EC
AUX / Aux	Auxiliary
AWG	American Wire Gauge
BAR	Block Auto-Reclose signal.
BCD	Binary Coded Decimal
BCR	Binary Counter Reading
BDEW	Bundesverband der Energie- und Wasserwirtschaft Startseite (i.e. German Association of Energy and Water Industries)
BMP	BitMaP – a file format for a computer graphic
BOP	Blocking Overreach Protection - a blocking aided-channel scheme.
BPDU	Bridge Protocol Data Unit
BRCB	Buffered Report Control Block
BRP	Beacon Redundancy Protocol
BU	Backup: Typically a back-up protection element
C/O	A ChangeOver contact having normally-closed and normally-open connections: Often called a “form C” contact.
CB	Circuit Breaker
CB Aux.	Circuit Breaker auxiliary contacts: Indication of the breaker open/closed status.
CBF	Circuit Breaker Failure protection
CDC	Common Data Class
CF	Control Function
Ch	Channel: usually a communications or signaling channel
Check Synch	Check Synchronizing function
CLIO	Current Loop Input Output: 0-1 mA/0-10 mA/0-20 mA/4-20 mA transducer inputs and outputs CLI = current loop input - 0-1 mA/0-10 mA/0-20 mA/4-20 mA transducer input CLO = current loop output - 0-1 mA/0-10 mA/0-20 mA/4-20 mA transducer output
CIP	Critical Infrastructure Protection standards

Term	Description
CLK / Clk	Clock
Cls	Close - generally used in the context of close functions in circuit breaker control.
CMV	Complex Measured Value
CNV	Current No Volts
CPNI	Centre for the Protection of National Infrastructure
CRC	Cyclic Redundancy Check
CRP	Cross-network Redundancy Protocol
CRV	Curve (file format for curve information)
CRx	Channel Receive: Typically used to indicate a teleprotection signal received.
CS	Check Synchronism.
CSV	Comma Separated Values (a file format for database information)
CT	Current Transformer
CTRL	Control - as used for the Control Inputs function
CTS	Current Transformer Supervision: To detect CT input failure.
CTx	Channel Transmit: Typically used to indicate a teleprotection signal send.
CUL	Canadian Underwriters Laboratory
CVT	Capacitor-coupled Voltage Transformer - equivalent to terminology CCVT.
DAU	Data Acquisition Unit
DC	Data Concentrator
DC / dc	Direct Current
DCC	An Omicron compatible format
DCE	Data Communication Equipment
DDB	Digital Data Bus within the programmable scheme logic: A logic point that has a zero or 1 status. DDB signals are mapped in logic to customize the relay's operation.
DDR	Dynamic Disturbance Recorder
DEF	Directional Earth Fault protection: A directionalized ground fault aided scheme.
df/dt	Rate of Change of Frequency
df/dt>1	First stage of df/dt protection
DFT	Discrete Fourier Transform
DG	Distributed Generation
DHCP	Dynamic Host Configuration Protocol
DHM	Dual Homing Manager
DHP	Dual Homing Protocol
Diff	Differential protection.
DIN	Deutsches Institut für Normung (German standards body)
Dist	Distance protection.
DITA	Darwinian Information Typing Architecture
DLDB	Dead-Line Dead-Bus : In system synchronism check, indication that both the line and bus are de-energised.
DLLB	Dead-Line Live-Bus : In system synchronism check, indication that the line is de-energised whilst the bus is energised.
DLR	Dynamic Line Rating
DLY / Dly	Time Delay
DMT	Definite Minimum Time

Term	Description
DNP	Distributed Network Protocol
DPWS	Device Profile for Web Services
DSP	Digital Signal Processor
DST	Daylight Saving Time
DT	Definite Time: in the context of protection elements: An element which always responds with the same constant time delay on operation. Abbreviation of "Dead Time" in the context of auto-reclose:
DTD	Document Type Definition
DTOC	Definite Time Overcurrent
DTS	Date and Time Stamp
EF or E/F	Earth Fault (Directly equivalent to Ground Fault)
EIA	Electronic Industries Alliance
ELR	Environmental Lapse Rate
EMC	ElectroMagnetic Compatibility
ENA	Energy Networks Association
ER	Engineering Recommendation
ESD	Electrostatic Discharge
FAA	Ageing Acceleration Factor: Used by Loss of Life (LOL) element
FFail	A field failure (loss of excitation) element: Could be labeled 40 in ANSI terminology.
FFT	Fast Fourier Transform
FIR	Finite Impulse Response
FLC	Full load current: The nominal rated current for the circuit.
FLT / Flt	Fault - typically used to indicate faulted phase selection.
Fn or FN	Function
FPGA	Field Programmable Gate Array
FPS	Frames Per Second
FTP	File Transfer Protocol or Foil Twisted Pair
FWD, Fwd or Fwd.	Indicates an element responding to a flow in the "Forward" direction
Gen Diff	A generator differential element: Could be labeled 87G in ANSI terminology.
Gen-Xformer Diff	A generator-transformer differential element: Could be labeled 87GT in ANSI terminology.
GIF	Graphic Interchange Format – a file format for a computer graphic
GND / Gnd	Ground: used in distance settings to identify settings that relate to ground (earth) faults.
GOOSE	Generic Object Oriented Substation Event
GPS	Global Positioning System
GRP / Grp	Group. Typically an alternative setting group.
GSE	General Substation Event
GSSE	Generic Substation Status Event
GUESS	Generator Unintentional Energization at StandStill.
GUI	Graphical User Interface
HMI	Human Machine Interface

Term	Description
HSR	High-availability Seamless Ring
HTML	Hypertext Markup Language
I	Current
I/O	Input/Output
I/P	Input
IANA	Internet Assigned Numbers Authority
ICAO	International Civil Aviation Organization
ID	Identifier or Identification. Often a label used to track a software version installed.
IDMT	Inverse Definite Minimum Time. A characteristic whose trip time depends on the measured input (e.g. current) according to an inverse-time curve.
IEC	International Electro-technical Commission
IED	Intelligent Electronic Device - a term used to describe microprocessor-based controllers of power system equipment. Common types of IEDs include protective relaying devices, load tap changer controllers, circuit breaker controllers, capacitor bank switches, recloser controllers, voltage regulators, etc.
IEEE	Institute of Electrical and Electronics Engineers
IETF	Internet Engineering Task Force
IIR	Infinite Impulse Response
Inh	An Inhibit signal
Inst	An element with Instantaneous operation: i.e. having no deliberate time delay.
IP	Internet Protocol
IRIG	InterRange Instrumentation Group
ISA	International Standard Atmosphere
ISA	Instrumentation Systems and Automation Society
ISO	International Standards Organization
JPEF	Joint Photographic Experts Group – a file format for a computer graphic
L	Live
LAN	Local Area Network
LCD	Liquid Crystal Display: The front-panel text display on the relay.
LD	Level Detector: An element responding to a current or voltage below its set threshold.
LDOV	Level Detector for Overvoltage
LDUV	Level Detector for Undervoltage
LED	Light Emitting Diode: Red or green indicator on the front-panel.
LLDB	Live-Line Dead-Bus : In system synchronism check, indication that the line is energized whilst the bus is de-energized.
Ln	Natural logarithm
LN	Logical Node
LoL	A Loss of Load scheme, providing a fast distance trip without needing a signaling channel.
LPDU	Link Protocol Data Unit
LPHD	Logical Physical Device
MC	MultiCast
MCB	Miniature Circuit Breaker
MIB	Management Information Base
MICS	Model Implementation Conformance Statement

Term	Description
MIDOS	Modular Integrated DrawOut System
MMF	Magneto-Motive Force
MMS	Manufacturing Message Specification
MRP	Media Redundancy Protocol
MU	Merging Unit
MV	Measured Value
N	Neutral
N/A	Not Applicable
N/C	A Normally Closed or “break” contact: Often called a “form B” contact.
N/O	A Normally Open or “make” contact: Often called a “form A” contact.
NERC	North American Reliability Corporation
NIST	National Institute of Standards and Technology
NPS	Negative Phase Sequence
NVD	Neutral voltage displacement: Equivalent to residual overvoltage protection.
NXT	Abbreviation of “Next”: In connection with hotkey menu navigation.
O/C	Overcurrent
O/P	Output
OCB	Oil Circuit Breaker
OID	Object IDentifier
Opto	An Optically coupled logic input. Alternative terminology: binary input.
OSI	Open Systems Interconnection
PCB	Printed Circuit Board
PCT	Protective Conductor Terminal (Ground)
PDC	Phasor Data Concentrator
Ph	Phase - used in distance settings to identify settings that relate to phase-phase faults.
PICS	Protocol Implementation Conformance Statement
PMU	Phasor Measurement Unit
PNG	Portable Network Graphics – a file format for a computer graphic
Pol	Polarize - typically the polarizing voltage used in making directional decisions.
POR	A Permissive OverReaching transfer trip scheme (alternative terminology: POTT).
PRP	Parallel Redundancy Protocol
PSB	Power Swing Blocking, to detect power swing/out of step functions (ANSI 78).
PSL	Programmable Scheme Logic: The part of the relay’s logic configuration that can be modified by the user, using the graphical editor within MiCOM S1 Studio software.
PSlip	A Pole slip (out of step - OOS) element: could be labeled 78 in ANSI terminology.
PT	Power Transformer
PTP	Precision Time Protocol
PUR	A Permissive UnderReaching transfer trip scheme (alternative terminology: PUTT).
Q	Quantity defined as per unit value
R	Resistance
R&TTE	Radio and Telecommunications Terminal Equipment

Term	Description
RBAC	Role Based Access Control
RCA	Relay Characteristic Angle - The center of the directional characteristic.
REB	Redundant Ethernet Board
REF	Restricted Earth Fault
Rev.	Indicates an element responding to a flow in the "reverse" direction
RMS / rms	Root mean square. The equivalent a.c. current: Taking into account the fundamental, plus the equivalent heating effect of any harmonics.
RP	Rear Port: The communication ports on the rear of the IED
RS232	A common serial communications standard defined by the EIA
RS485	A common serial communications standard defined by the EIA (multi-drop)
RST or Rst	Reset generally used in the context of reset functions in circuit breaker control.
RSTP	Rapid Spanning Tree Protocol
RTD	Resistance Temperature Device
RTU	Remote Terminal Unit
Rx	Receive: Typically used to indicate a communication transmit line/pin.
SBS	Straight Binary Second
SC	Synch-Check or system Synchronism Check.
SCADA	Supervisory Control and Data Acquisition
SCL	Substation Configuration Language
SCU	Substation Control Unit
SEF	Sensitive Earth Fault Protection
Sen	Sensitive
SHM	Self-Healing Manager
SHP	Self Healing Protocol
SIR	Source Impedance Ratio
SLA	Service Level Agreement
SMV	Sampled Measured Values
SNTP	Simple Network Time Protocol
SOA	Service Oriented Architecture
SOAP	Simple Object Access Protocol
SOC	Second of Century
SOTF	Switch on to Fault protection. Modified protection on manual closure of the circuit breaker.
SP	Single pole.
SPAR	Single pole auto-reclose.
SPC	Single Point Controllable
SPDT	Single Pole Dead Time. The dead time used in single pole auto-reclose cycles.
SPS	Single Point Status
SQRT	Square Root
SSL	Source Impedance Ratio
STP	Shielded Twisted Pair or Spanning Tree Protocol
SV	Sampled Values
SVC	Sampled Value Model
SVM	Sampled Value Model

Term	Description
TAF	Turbine Abnormal Frequency
TCP	Transmission Control Protocol
TCS	Second of Century
TCS	Trip Circuit Supervision
TD	Time Dial. The time dial multiplier setting: Applied to inverse-time curves (ANSI/IEEE).
TE	Unit for case measurements: One inch = 5TE units
THD	Total Harmonic Distortion
TICS	Technical Issues Conformance Statement
TIFF	Tagged Image File Format – a file format for a computer graphic
TLS	Transport Layer Security protocol
TMS	Time Multiplier Setting: Applied to inverse-time curves (IEC)
TOC	Trip On Close (“line check”) protection. Offers SOTF and TOR functionality.
TOR	Trip On Reclose protection. Modified protection on autoreclosure of the circuit breaker.
TP	Two-Part
TUC	Timed UnderCurrent
TVE	Total Vector Error
Tx	Transmit
UDP	User Datagram Protocol
UL	Underwriters Laboratory
UPCT	User Programmable Curve Tool
UTC	Universal Time Coordinated
V	Voltage
VA	Phase A voltage: Sometimes L1, or red phase
VB	Phase B voltage: Sometimes L2, or yellow phase
VC	Phase C voltage: Sometimes L3, or blue phase
VCO	Voltage Controlled Overcurrent element
VDEP OC>	A voltage dependent overcurrent element: could be a voltage controlled or voltage restrained overcurrent element and could be labeled 51V in ANSI terminology.
VDR	Voltage Dependant Resistor
V/Hz	An overfluxing element, flux is proportional to voltage/frequency: could be labeled 24 in ANSI terminology.
Vk	IEC knee point voltage of a current transformer.
VT	Voltage Transformer
VTs	Voltage Transformer Supervision: To detect VT input failure.
WAN	Wide Area Network
Xformer	Transformer
XML	Extensible Markup Language
XSD	XML Schema Definition

Table 1 - Acronyms and abbreviations

2 COMPANY PROPRIETARY TERMS

Symbol	Description
Courier	Schneider Electric's proprietary SCADA communications protocol
Metrosil	Brand of non-linear resistor produced by M&I Materials Ltd.
MiCOM	Schneider Electric's brand of protection relays

Table 2 - Company-proprietary terms

3 ANSI TERMS

ANSI no.	Description
3PAR	Three pole auto-reclose.
3PDT	Three pole dead time. The dead time used in three pole auto-reclose cycles.
52a	A circuit breaker closed auxiliary contact: The contact is in the same state as the breaker primary contacts
52b	A circuit breaker open auxiliary contact: The contact is in the opposite state to the breaker primary contacts
64R	Rotor earth fault protection
64S	100% stator earth (ground) fault protection using a low frequency injection method.

Table 3 - ANSI abbreviations

ANSI no.	Function	Description
Current Protection Functions		
50/51	Phase overcurrent	Three-phase protection against overloads and phase-to-phase short-circuits.
50N/51N	Earth fault	Earth fault protection based on measured or calculated residual current values: <ul style="list-style-type: none"> 50N/51N: residual current calculated or measured by 3 phase current sensors
50G/51G	Sensitive earth fault	Sensitive earth fault protection based on measured residual current values: <ul style="list-style-type: none"> 50G/51G: residual current measured directly by a specific sensor such as a core balance CT
50BF	Breaker failure	If a breaker fails to be triggered by a tripping order, as detected by the non-extinction of the fault current, this backup protection sends a tripping order to the upstream or adjacent breakers.
46	Negative sequence / unbalance	Protection against phase unbalance, detected by the measurement of negative sequence current: <ul style="list-style-type: none"> sensitive protection to detect 2-phase faults at the ends of long lines protection of equipment against temperature build-up, caused by an unbalanced power supply, phase inversion or loss of phase, and against phase current unbalance
46BC	Broken conductor protection	Protection against phase imbalance, detected by measurement of I2/I1.
49RMS	Thermal overload	Protection against thermal damage caused by overloads on machines (transformers, motors or generators). The thermal capacity used is calculated according to a mathematical model which takes into account: <ul style="list-style-type: none"> current RMS values ambient temperature negative sequence current, a cause of motor rotor temperature rise
Re-Closer		
79	Recloser	Automation device used to limit down time after tripping due to transient or semipermanent faults on overhead lines. The recloser orders automatic reclosing of the breaking device after the time delay required to restore the insulation has elapsed. Recloser operation is easy to adapt for different operating modes by parameter setting.
Directional Current Protection		
67N/67NC type 1 and 67	Directional phase overcurrent	Phase-to-phase short-circuit protection, with selective tripping according to fault current direction. It comprises a phase overcurrent function associated with direction detection, and picks up if the phase overcurrent function in the chosen direction (line or busbar) is activated for at least one of the three phases.

ANSI no.	Function	Description
67N/67NC	Directional earth fault	Earth fault protection, with selective tripping according to fault current direction. Three types of operation: <ul style="list-style-type: none"> • Type 1: the protection function uses the projection of the I0 vector • Type 2: the protection function uses the I0 vector magnitude with half-plane tripping zone • Type 3: the protection function uses the I0 vector magnitude with angular sector tripping zone
67N/67NC type 1	Directional current protection	Directional earth fault protection for impedant, isolated or compensated neutral systems, based on the projection of measured residual current.
67N/67NC type 2	Directional current protection	Directional overcurrent protection for impedance and solidly earthed systems, based on measured or calculated residual current. It comprises an earth fault function associated with direction detection, and picks up if the earth fault function in the chosen direction (line or busbar) is activated.
67N/67NC type 3	Directional current protection	Directional overcurrent protection for distribution networks in which the neutral earthing system varies according to the operating mode, based on measured residual current. It comprises an earth fault function associated with direction detection (angular sector tripping zone defined by 2 adjustable angles), and picks up if the earth fault function in the chosen direction (line or busbar) is activated.
Directional Power Protection Functions		
32P	Directional active overpower	Two-way protection based on calculated active power, for the following applications: <ul style="list-style-type: none"> • active overpower protection to detect overloads and allow load shedding • reverse active power protection: <ul style="list-style-type: none"> • against generators running like motors when the generators consume active power • against motors running like generators when the motors supply active power
32Q/40	Directional reactive overpower	Two-way protection based on calculated reactive power to detect field loss on synchronous machines: <ul style="list-style-type: none"> • reactive overpower protection for motors which consume more reactive power with field loss • reverse reactive overpower protection for generators which consume reactive power with field loss.
Machine Protection Functions		
37	Phase undercurrent	Protection of pumps against the consequences of a loss of priming by the detection of motor no-load operation. It is sensitive to a minimum of current in phase 1, remains stable during breaker tripping and may be inhibited by a logic input.
48/51LR/14	Locked rotor / excessive starting time	Protection of motors against overheating caused by: <ul style="list-style-type: none"> • excessive motor starting time due to overloads (e.g. conveyor) or insufficient supply voltage. The reacceleration of a motor that is not shut down, indicated by a logic input, may be considered as starting. <ul style="list-style-type: none"> • locked rotor due to motor load (e.g. crusher): <ul style="list-style-type: none"> • in normal operation, after a normal start • directly upon starting, before the detection of excessive starting time, with detection of locked rotor by a zero speed detector connected to a logic input, or by the underspeed function.
66	Starts per hour	Protection against motor overheating caused by: <ul style="list-style-type: none"> • too frequent starts: motor energizing is inhibited when the maximum allowable number of starts is reached, after counting of: <ul style="list-style-type: none"> • starts per hour (or adjustable period) • consecutive motor hot or cold starts (reacceleration of a motor that is not shut down, indicated by a logic input, may be counted as a start) • starts too close together in time: motor re-energizing after a shutdown is only allowed after an adjustable waiting time.

ANSI no.	Function	Description
50V/51V	Voltage-restrained overcurrent	Phase-to-phase short-circuit protection, for generators. The current tripping set point is voltage-adjusted in order to be sensitive to faults close to the generator which cause voltage drops and lowers the short-circuit current.
26/63	Thermostat/Buchholz	Protection of transformers against temperature rise and internal faults via logic inputs linked to devices integrated in the transformer.
38/49T	Temperature monitoring	Protection that detects abnormal temperature build-up by measuring the temperature inside equipment fitted with sensors: <ul style="list-style-type: none"> transformer: protection of primary and secondary windings motor and generator: protection of stator windings and bearings.
Voltage Protection Functions		
27D	Positive sequence undervoltage	Protection of motors against faulty operation due to insufficient or unbalanced network voltage, and detection of reverse rotation direction.
27R	Remanent undervoltage	Protection used to check that remanent voltage sustained by rotating machines has been cleared before allowing the busbar supplying the machines to be re-energized, to avoid electrical and mechanical transients.
27	Undervoltage	Protection of motors against voltage sags or detection of abnormally low network voltage to trigger automatic load shedding or source transfer. Works with phase-to-phase voltage.
59	Overvoltage	Detection of abnormally high network voltage or checking for sufficient voltage to enable source transfer. Works with phase-to-phase or phase-to-neutral voltage, each voltage being monitored separately.
59N	Neutral voltage displacement	Detection of insulation faults by measuring residual voltage in isolated neutral systems.
47	Negative sequence overvoltage	Protection against phase unbalance resulting from phase inversion, unbalanced supply or distant fault, detected by the measurement of negative sequence voltage.
Frequency Protection Functions		
81O	Overfrequency	Detection of abnormally high frequency compared to the rated frequency, to monitor power supply quality. Other organizations may use 81H instead of 81O.
81U	Underfrequency	Detection of abnormally low frequency compared to the rated frequency, to monitor power supply quality. The protection may be used for overall tripping or load shedding. Protection stability is ensured in the event of the loss of the main source and presence of remanent voltage by a restraint in the event of a continuous decrease of the frequency, which is activated by parameter setting. Other organizations may use 81L instead of 81U.
81R	Rate of change of frequency	<p>Protection function used for fast disconnection of a generator or load shedding control. Based on the calculation of the frequency variation, it is insensitive to transient voltage disturbances and therefore more stable than a phase-shift protection function.</p> <p>Disconnection</p> <p>In installations with autonomous production means connected to a utility, the “rate of change of frequency” protection function is used to detect loss of the main system in view of opening the incoming circuit breaker to:</p> <ul style="list-style-type: none"> protect the generators from a reconnection without checking synchronization avoid supplying loads outside the installation. <p>Load shedding</p> <p>The “rate of change of frequency” protection function is used for load shedding in combination with the underfrequency protection to:</p> <ul style="list-style-type: none"> either accelerate shedding in the event of a large overload or inhibit shedding following a sudden drop in frequency due to a problem that should not be solved by shedding.
Dynamic Line Rating (DLR) Protection Functions		

ANSI no.	Function	Description
49DLR	Dynamic line rating (DLR)	<p>Protection of overhead lines based on calculation of rating or ampacity to dynamically take into account the effect of prevailing weather conditions as monitored by external sensors for:</p> <ul style="list-style-type: none">• Ambient Temperature• Wind Velocity• Wind Direction• Solar Radiation

Table 4 - ANSI descriptions

4 **CONCATENATED TERMS**

Term
Undercurrent
Overcurrent
Overfrequency
Underfrequency
Undervoltage
Overvoltage

Table 5 - Concatenated terms

5 UNITS FOR DIGITAL COMMUNICATIONS

Unit	Description
b	bit
B	Byte
kb	Kilobit(s)
kbps	Kilobits per second
kB	Kilobyte(s)
Mb	Megabit(s)
Mbps	Megabits per second
MB	Megabyte(s)
Gb	Gigabit(s)
Gbps	Gigabits per second
GB	Gigabyte(s)
Tb	Terabit(s)
Tbps	Terabits per second
TB	Terabyte(s)

Table 6 - Units for digital communications

6

AMERICAN VS BRITISH ENGLISH TERMINOLOGY

British English	American English
...ae...	...e...
...ence	...ense
...ise	...ize
...oe...	...e...
...ogue	...og
...our	...or
...ourite	...orite
...que	...ck
...re	...er
...yse	...yze
Aluminium	Aluminum
Centre	Center
Earth	Ground
Fibre	Fiber
Ground	Earth
Speciality	Specialty

Table 7 - American vs British English terminology

7 LOGIC SYMBOLS AND TERMS

Symbol	Description	Units
&	Logical "AND": Used in logic diagrams to show an AND-gate function.	
Σ	"Sigma": Used to indicate a summation, such as cumulative current interrupted.	
τ	"Tau": Used to indicate a time constant, often associated with thermal characteristics.	
ω	System angular frequency	rad
<	Less than: Used to indicate an "under" threshold, such as undercurrent (current dropout).	
>	Greater than: Used to indicate an "over" threshold, such as overcurrent (current overload)	
o	A small circle on the input or output of a logic gate: Indicates a NOT (invert) function.	
1	Logical "OR": Used in logic diagrams to show an OR-gate function.	
ABC	Clockwise phase rotation.	
ACB	Anti-Clockwise phase rotation.	
C	Capacitance	A
df/dt	Rate of Change of Frequency protection	Hz/s
df/dt>1	First stage of df/dt protection	Hz/s
F<	Underfrequency protection: Could be labeled 81-U in ANSI terminology.	Hz
F>	Overfrequency protection: Could be labeled 81-O in ANSI terminology.	Hz
F<1	First stage of under frequency protection: Could be labeled 81-U in ANSI terminology.	Hz
F>1	First stage of over frequency protection: Could be labeled 81-O in ANSI terminology.	Hz
f_{\max}	Maximum required operating frequency	Hz
f_{\min}	Minimum required operating frequency	Hz
f_n	Nominal operating frequency	Hz
I	Current	A
I^{\wedge}	Current raised to a power: Such as when breaker statistics monitor the square of ruptured current squared (\wedge power = 2).	An
I'f	Maximum internal secondary fault current (may also be expressed as a multiple of I_n)	A
I<	An undercurrent element: Responds to current dropout.	A
I>>	Current setting of short circuit element	In
I>	A phase overcurrent protection: Could be labeled 50/51 in ANSI terminology.	A
I>1	First stage of phase overcurrent protection: Could be labeled 51-1 in ANSI terminology.	A
I>2	Second stage of phase overcurrent protection: Could be labeled 51-2 in ANSI terminology.	A
I>3	Third stage of phase overcurrent protection: Could be labeled 51-3 in ANSI terminology.	A
I>4	Fourth stage of phase overcurrent protection: Could be labeled 51-4 in ANSI terminology.	A
I0	Earth fault current setting Zero sequence current: Equals one third of the measured neutral/residual current.	A
I1	Positive sequence current.	A
I2	Negative sequence current.	A
I2>	Negative sequence overcurrent protection (NPS element).	A
I2pol	Negative sequence polarizing current.	A
I2therm>	A negative sequence thermal element: Could be labeled 46T in ANSI terminology.	
IA	Phase A current: Might be phase L1, red phase.. or other, in customer terminology.	A
IB	Phase B current: Might be phase L2, yellow phase.. or other, in customer terminology.	A
IC	Phase C current: Might be phase L3, blue phase.. or other, in customer terminology.	A
I _{diff}	Current setting of biased differential element	A

Symbol	Description	Units
If	Maximum secondary through-fault current	A
If max	Maximum secondary fault current (same for all feeders)	A
If max int	Maximum secondary contribution from a feeder to an internal fault	A
If Z1	Maximum secondary phase fault current at Zone 1 reach point	A
Ife	Maximum secondary through fault earth current	A
IfeZ1	Maximum secondary earth fault current at Zone 1 reach point	A
Ifn	Maximum prospective secondary earth fault current or $31 \times I >$ setting (whichever is lowest)	A
Ifp	Maximum prospective secondary phase fault current or $31 \times I >$ setting (whichever is lowest)	A
I _m	Mutual current	A
IM64	InterMiCOM64.	
IMx	InterMiCOM64 bit (x=1 to 16)	
I _n	Current transformer nominal secondary current. The rated nominal current of the relay: Software selectable as 1 amp or 5 amp to match the line CT input.	A
IN	Neutral current, or residual current: This results from an internal summation of the three measured phase currents.	A
IN>	A neutral (residual) overcurrent element: Detects earth/ground faults.	A
IN>1	First stage of ground overcurrent protection: Could be labeled 51N-1 in ANSI terminology.	A
IN>2	Second stage of ground overcurrent protection: Could be labeled 51N-2 in ANSI terminology.	A
Inst	An element with "instantaneous" operation: i.e. having no deliberate time delay.	
I/O	Inputs and Outputs - used in connection with the number of optocoupled inputs and output contacts within the relay.	
I/P	Input	
Iref	Reference current of P63x calculated from the reference power and nominal voltage	A
IREF>	A Restricted Earth Fault overcurrent element: Detects earth (ground) faults. Could be labeled 64 in ANSI terminology.	A
IRm2	Second knee-point bias current threshold setting of P63x biased differential element	A
Is	Value of stabilizing current	A
IS1	Differential current pick-up setting of biased differential element	A
IS2	Bias current threshold setting of biased differential element	A
I _{SEF} >	Sensitive earth fault overcurrent element.	A
Isn	Rated secondary current (I secondary nominal)	A
Isp	Stage 2 and 3 setting	A
Ist	Motor start up current referred to CT secondary side	A
K	Dimensioning factor	
K ₁	Lower bias slope setting of biased differential element	%
K ₂	Higher bias slope setting of biased differential element	%
K _e	Dimensioning factor for earth fault	
km	Distance in kilometers	
K _{max}	Maximum dimensioning factor	
K _{rpa}	Dimensioning factor for reach point accuracy	
K _s	Dimensioning factor dependent upon through fault current	
K _{ssc}	Short circuit current coefficient or ALF	
K _t	Dimensioning factor dependent upon operating time	
kZm	The mutual compensation factor (mutual compensation of distance elements and fault locator for parallel line coupling effects).	



Symbol	Description	Units
kZN	The residual compensation factor: Ensuring correct reach for ground distance elements.	
L	Inductance	A
m1	Lower bias slope setting of P63x biased differential element	None
m2	Higher bias slope setting of P63x biased differential element	None
mi	Distance in miles.	
N	Indication of "Neutral" involvement in a fault: i.e. a ground (earth) fault.	
-P>	A reverse power (W) element: could be labeled 32R in ANSI terminology.	
P>	An overpower (W) element: could be labeled 32O in ANSI terminology.	
P<	A low forward power (W) element: could be labeled 32L in ANSI terminology.	
P1	Used in IEC terminology to identify the primary CT terminal polarity: Replace by a dot when using ANSI standards.	
P2	Used in IEC terminology to identify the primary CT terminal polarity: The non-dot terminal.	
P _n	Rotating plant rated single phase power	W
PN>	Wattmetric earth fault protection: Calculated using residual voltage and current quantities.	
Q<	A reactive under power (VAr) element	
R	Resistance (Ω)	Ω
R< or 64S R<	A 100% stator earth (ground) fault via low frequency injection under resistance element: could be labeled 64S in ANSI terminology.	
R Gnd.	A distance zone resistive reach setting: Used for ground (earth) faults.	
R Ph	A distance zone resistive reach setting used for Phase-Phase faults.	
Rct	Secondary winding resistance	Ω
RI	Resistance of single lead from relay to current transformer	Ω
Rr	Resistance of any other protective relays sharing the current transformer	Ω
Rrn	Resistance of relay neutral current input	Ω
Rrp	Resistance of relay phase current input	Ω
Rs	Value of stabilizing resistor	Ω
Rx	Receive: typically used to indicate a communication receive line/pin.	
S<	An apparent under power (VA) element	
S1	Used in IEC terminology to identify the secondary CT terminal polarity: Replace by a dot when using ANSI standards.	
S2	Used in IEC terminology to identify the secondary CT terminal polarity: The non-dot terminal. Also used to signify negative sequence apparent power, $S2 = V2 \times I2$.	
S2>	A negative sequence apparent power element, $S2 = V2 \times I2$.	
t	A time delay.	
t'	Duration of first current flow during auto-reclose cycle	s
T1	Primary system time constant	s
TF	Through Fault monitoring	
tfr	Auto-reclose dead time	s
Thermal I>	A stator thermal overload element: could be labeled 49 in ANSI terminology.	
Thru/TF	Through Fault monitoring	
tldiff	Current differential operating time	s
Ts	Secondary system time constant	s
Tx	Transmit: typically used to indicate a communication transmit line/pin.	
V	Voltage.	V
V<	An undervoltage element: could be labeled 27 in ANSI terminology	V

Symbol	Description	Units
V<1	First stage of undervoltage protection: Could be labeled 27-1 in ANSI terminology.	V
V<2	Second stage of undervoltage protection: Could be labeled 27-2 in ANSI terminology.	V
V>	An overvoltage element: could be labeled 59 in ANSI terminology	V
V>1	First stage of overvoltage protection: Could be labeled 59-1 in ANSI terminology.	V
V>2	Second stage of overvoltage protection: Could be labeled 59-2 in ANSI terminology.	V
V0	Zero sequence voltage: Equals one third of the measured neutral/residual voltage.	V
V1	Positive sequence voltage.	V
V2	Negative sequence voltage.	V
V2>	A negative phase sequence (NPS) overvoltage element: could be labeled 47 in ANSI terminology.	
V _{2pol}	Negative sequence polarizing voltage.	V
V _A	Phase A voltage: Might be phase L1, red phase.. or other, in customer terminology.	V
V _B	Phase B voltage: Might be phase L2, yellow phase.. or other, in customer terminology.	V
V _C	Phase C voltage: Might be phase L3, blue phase.. or other, in customer terminology.	V
V _f	Theoretical maximum voltage produced if CT saturation did not occur	V
V _{in}	Input voltage e.g. to an opto-input	V
V _k	Required CT knee-point voltage. IEC knee point voltage of a current transformer.	V
V _N	Neutral voltage displacement, or residual voltage.	V
V _{N>}	A residual (neutral) overvoltage element: could be labeled 59N in ANSI terminology.	V
V _n	Nominal voltage	V
V _n	The rated nominal voltage of the relay: To match the line VT input.	V
V _{N>1}	First stage of residual (neutral) overvoltage protection.	V
V _{N>2}	Second stage of residual (neutral) overvoltage protection.	V
V _{N3H>}	A 100% stator earth (ground) fault 3rd harmonic residual (neutral) overvoltage element: could be labeled 59TN in ANSI terminology.	
V _{N3H<}	A 100% stator earth (ground) fault 3rd harmonic residual (neutral) undervoltage element: could be labeled 27TN in ANSI terminology.	
V _{res.}	Neutral voltage displacement, or residual voltage.	V
V _s	Value of stabilizing voltage	V
V _x	An auxiliary supply voltage: Typically the substation battery voltage used to power the relay.	V
WI	Weak Infeed logic used in teleprotection schemes.	
X	Reactance	None
X/R	Primary system reactance/resistance ratio	None
X _e /R _e	Primary system reactance/resistance ratio for earth loop	None
X _t	Transformer reactance (per unit)	p.u.
Y	Admittance	p.u.
Z	Impedance	p.u.
Z<	An under impedance element: could be labeled 21 in ANSI terminology.	
Z0	Zero sequence impedance.	
Z1	Positive sequence impedance.	
Z1	Zone 1 distance protection.	
Z1X	Reach-stepped Zone 1X, for zone extension schemes used with auto-reclosure.	
Z2	Negative sequence impedance.	
Z2	Zone 2 distance protection.	
ZP	Programmable distance zone that can be set forward or reverse looking.	

Symbol	Description	Units
Zs	Used to signify the source impedance behind the relay location.	
Φ_{al}	Accuracy limit flux	Wb
Ψ_r	Remanent flux	Wb
Ψ_s	Saturation flux	Wb

Table 8 - Logic Symbols and Terms

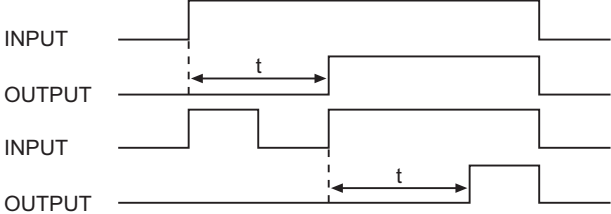
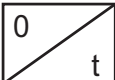
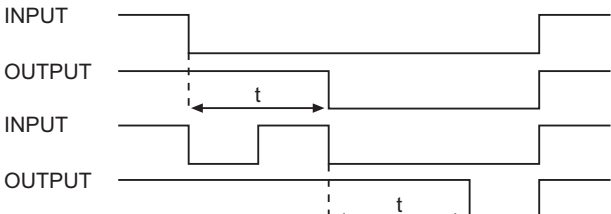
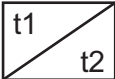
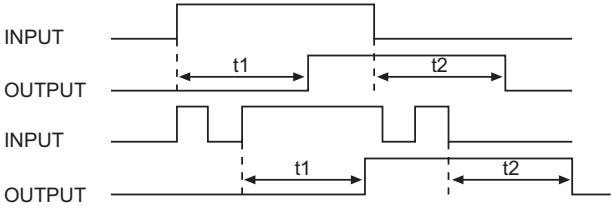
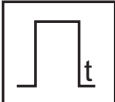
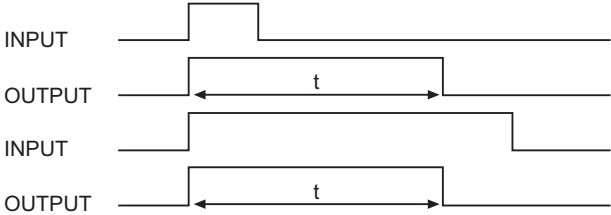
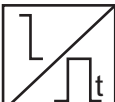
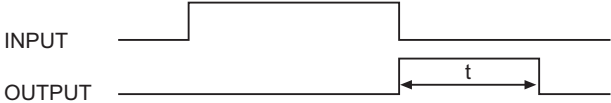
8 LOGIC TIMERS

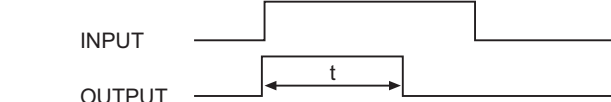
Logic symbols	Explanation	Time chart
	<p>Delay on pick-up timer, t</p>	
	<p>Delay on drop-off timer, t</p>	
	<p>Delay on pick-up/drop-off timer</p>	
	<p>Pulse timer</p>	
	<p>Pulse pick-up falling edge</p>	
	<p>Pulse pick-up raising edge</p>	

Logic symbols	Explanation	Time chart
	Latch	
	Dwell timer	
	Straight (non latching): Hold value until input reset signal	

Table 9 - Logic Timers

9 LOGIC GATES



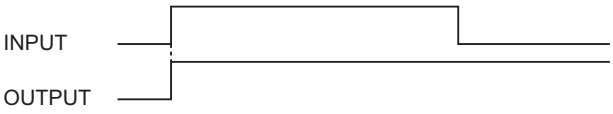
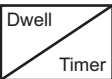
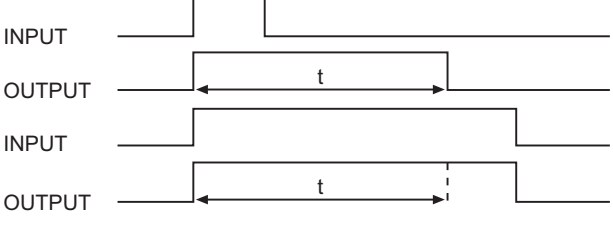
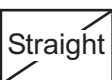
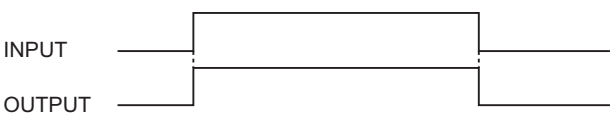

AND GATE																																																																																																									
Symbol	Truth Table	Symbol	Truth Table	Symbol	Truth Table																																																																																																				
	<table border="1" style="margin: auto;"> <tr><th colspan="2">IN</th><th>OUT</th></tr> <tr><td>0</td><td>1</td><td>0</td></tr> <tr><td>0</td><td>1</td><td>0</td></tr> <tr><td>0</td><td>1</td><td>0</td></tr> <tr><td>1</td><td>0</td><td>0</td></tr> <tr><td>1</td><td>1</td><td>1</td></tr> </table>	IN		OUT	0	1	0	0	1	0	0	1	0	1	0	0	1	1	1		<table border="1" style="margin: auto;"> <tr><th colspan="2">IN</th><th>OUT</th></tr> <tr><td>A</td><td>B</td><td>Y</td></tr> <tr><td>0</td><td>0</td><td>0</td></tr> <tr><td>0</td><td>1</td><td>1</td></tr> <tr><td>1</td><td>0</td><td>0</td></tr> <tr><td>1</td><td>1</td><td>0</td></tr> </table>	IN		OUT	A	B	Y	0	0	0	0	1	1	1	0	0	1	1	0		<table border="1" style="margin: auto;"> <tr><th colspan="2">IN</th><th>OUT</th></tr> <tr><td>A</td><td>B</td><td>Y</td></tr> <tr><td>0</td><td>0</td><td>1</td></tr> <tr><td>0</td><td>1</td><td>1</td></tr> <tr><td>1</td><td>0</td><td>1</td></tr> <tr><td>1</td><td>1</td><td>0</td></tr> </table>	IN		OUT	A	B	Y	0	0	1	0	1	1	1	0	1	1	1	0																																														
IN		OUT																																																																																																							
0	1	0																																																																																																							
0	1	0																																																																																																							
0	1	0																																																																																																							
1	0	0																																																																																																							
1	1	1																																																																																																							
IN		OUT																																																																																																							
A	B	Y																																																																																																							
0	0	0																																																																																																							
0	1	1																																																																																																							
1	0	0																																																																																																							
1	1	0																																																																																																							
IN		OUT																																																																																																							
A	B	Y																																																																																																							
0	0	1																																																																																																							
0	1	1																																																																																																							
1	0	1																																																																																																							
1	1	0																																																																																																							
OR GATE																																																																																																									
Symbol	Truth Table	Symbol	Truth Table	Symbol	Truth Table																																																																																																				
	<table border="1" style="margin: auto;"> <tr><th colspan="2">IN</th><th>OUT</th></tr> <tr><td>A</td><td>B</td><td>Y</td></tr> <tr><td>0</td><td>0</td><td>0</td></tr> <tr><td>0</td><td>1</td><td>1</td></tr> <tr><td>1</td><td>0</td><td>1</td></tr> <tr><td>1</td><td>1</td><td>1</td></tr> </table>	IN		OUT	A	B	Y	0	0	0	0	1	1	1	0	1	1	1	1		<table border="1" style="margin: auto;"> <tr><th colspan="2">IN</th><th>OUT</th></tr> <tr><td>A</td><td>B</td><td>Y</td></tr> <tr><td>0</td><td>0</td><td>1</td></tr> <tr><td>0</td><td>1</td><td>1</td></tr> <tr><td>1</td><td>0</td><td>0</td></tr> <tr><td>1</td><td>1</td><td>1</td></tr> </table>	IN		OUT	A	B	Y	0	0	1	0	1	1	1	0	0	1	1	1		<table border="1" style="margin: auto;"> <tr><th colspan="2">IN</th><th>OUT</th></tr> <tr><td>A</td><td>B</td><td>Y</td></tr> <tr><td>0</td><td>0</td><td>1</td></tr> <tr><td>0</td><td>1</td><td>0</td></tr> <tr><td>1</td><td>0</td><td>0</td></tr> <tr><td>1</td><td>1</td><td>0</td></tr> </table>	IN		OUT	A	B	Y	0	0	1	0	1	0	1	0	0	1	1	0																																														
IN		OUT																																																																																																							
A	B	Y																																																																																																							
0	0	0																																																																																																							
0	1	1																																																																																																							
1	0	1																																																																																																							
1	1	1																																																																																																							
IN		OUT																																																																																																							
A	B	Y																																																																																																							
0	0	1																																																																																																							
0	1	1																																																																																																							
1	0	0																																																																																																							
1	1	1																																																																																																							
IN		OUT																																																																																																							
A	B	Y																																																																																																							
0	0	1																																																																																																							
0	1	0																																																																																																							
1	0	0																																																																																																							
1	1	0																																																																																																							
R - S FLIP-FLOP																																																																																																									
Symbol	Truth Table	Symbol	Truth Table	Symbol	Truth Table																																																																																																				
	<table border="1" style="margin: auto;"> <tr><th>A</th><th>B</th><th>QN</th><th>QN+</th><th>Active Mode</th></tr> <tr><td>0</td><td>0</td><td></td><td></td><td>Hold Mode</td></tr> <tr><td>0</td><td>1</td><td>0</td><td></td><td>Hold Mode</td></tr> <tr><td></td><td></td><td>1</td><td>0</td><td>Reset</td></tr> <tr><td></td><td></td><td>0</td><td>1</td><td>Set</td></tr> <tr><td>1</td><td>0</td><td>1</td><td></td><td>Hold Mode</td></tr> <tr><td>0</td><td>0</td><td>-</td><td>-</td><td>Inhibit Mode</td></tr> </table>	A	B	QN	QN+	Active Mode	0	0			Hold Mode	0	1	0		Hold Mode			1	0	Reset			0	1	Set	1	0	1		Hold Mode	0	0	-	-	Inhibit Mode		<table border="1" style="margin: auto;"> <tr><th>A</th><th>B</th><th>QN</th><th>QN+</th><th>Active Mode</th></tr> <tr><td>0</td><td>0</td><td>0</td><td></td><td>Hold Mode</td></tr> <tr><td></td><td></td><td>1</td><td>0</td><td>Reset</td></tr> <tr><td>0</td><td>1</td><td></td><td></td><td>Hold Mode</td></tr> <tr><td>1</td><td>0</td><td>-</td><td>-</td><td>Inhibit Mode</td></tr> <tr><td></td><td></td><td>0</td><td>1</td><td>Set</td></tr> <tr><td>0</td><td>1</td><td>1</td><td></td><td>Hold Mode</td></tr> </table>	A	B	QN	QN+	Active Mode	0	0	0		Hold Mode			1	0	Reset	0	1			Hold Mode	1	0	-	-	Inhibit Mode			0	1	Set	0	1	1		Hold Mode		<table border="1" style="margin: auto;"> <tr><th>A</th><th>B</th><th>QN</th><th>QN+</th><th>Active Mode</th></tr> <tr><td>0</td><td>0</td><td></td><td></td><td>Hold Mode</td></tr> <tr><td>0</td><td>1</td><td></td><td></td><td>0</td></tr> <tr><td></td><td></td><td>0</td><td>1</td><td>Set</td></tr> <tr><td>1</td><td>0</td><td>1</td><td></td><td>Hold Mode</td></tr> <tr><td>1</td><td>1</td><td></td><td></td><td>0</td></tr> </table> <p style="font-size: small;">* RD = Reset Dominant</p>	A	B	QN	QN+	Active Mode	0	0			Hold Mode	0	1			0			0	1	Set	1	0	1		Hold Mode	1	1			0
A	B	QN	QN+	Active Mode																																																																																																					
0	0			Hold Mode																																																																																																					
0	1	0		Hold Mode																																																																																																					
		1	0	Reset																																																																																																					
		0	1	Set																																																																																																					
1	0	1		Hold Mode																																																																																																					
0	0	-	-	Inhibit Mode																																																																																																					
A	B	QN	QN+	Active Mode																																																																																																					
0	0	0		Hold Mode																																																																																																					
		1	0	Reset																																																																																																					
0	1			Hold Mode																																																																																																					
1	0	-	-	Inhibit Mode																																																																																																					
		0	1	Set																																																																																																					
0	1	1		Hold Mode																																																																																																					
A	B	QN	QN+	Active Mode																																																																																																					
0	0			Hold Mode																																																																																																					
0	1			0																																																																																																					
		0	1	Set																																																																																																					
1	0	1		Hold Mode																																																																																																					
1	1			0																																																																																																					
EXCLUSIVE OR GATE																																																																																																									
Symbol	Truth Table	Symbol	Truth Table	Symbol	Truth Table																																																																																																				
	<table border="1" style="margin: auto;"> <tr><th colspan="2">IN</th><th>OUT</th></tr> <tr><td>A</td><td>B</td><td>Y</td></tr> <tr><td>0</td><td>0</td><td>0</td></tr> <tr><td>0</td><td>1</td><td>1</td></tr> <tr><td>1</td><td>0</td><td>1</td></tr> <tr><td>1</td><td>1</td><td>0</td></tr> </table>	IN		OUT	A	B	Y	0	0	0	0	1	1	1	0	1	1	1	0		<table border="1" style="margin: auto;"> <tr><th colspan="2">IN</th><th>OUT</th></tr> <tr><td>A</td><td>B</td><td>Y</td></tr> <tr><td>0</td><td>0</td><td>1</td></tr> <tr><td>0</td><td>1</td><td>0</td></tr> <tr><td>1</td><td>0</td><td>0</td></tr> <tr><td>1</td><td>1</td><td>1</td></tr> </table>	IN		OUT	A	B	Y	0	0	1	0	1	0	1	0	0	1	1	1		<table border="1" style="margin: auto;"> <tr><th colspan="2">IN</th><th>OUT</th></tr> <tr><td>A</td><td>B</td><td>Y</td></tr> <tr><td>0</td><td>0</td><td>1</td></tr> <tr><td>0</td><td>1</td><td>0</td></tr> <tr><td>1</td><td>0</td><td>0</td></tr> <tr><td>1</td><td>1</td><td>1</td></tr> </table>	IN		OUT	A	B	Y	0	0	1	0	1	0	1	0	0	1	1	1																																														
IN		OUT																																																																																																							
A	B	Y																																																																																																							
0	0	0																																																																																																							
0	1	1																																																																																																							
1	0	1																																																																																																							
1	1	0																																																																																																							
IN		OUT																																																																																																							
A	B	Y																																																																																																							
0	0	1																																																																																																							
0	1	0																																																																																																							
1	0	0																																																																																																							
1	1	1																																																																																																							
IN		OUT																																																																																																							
A	B	Y																																																																																																							
0	0	1																																																																																																							
0	1	0																																																																																																							
1	0	0																																																																																																							
1	1	1																																																																																																							
MULTI INPUT GATE																																																																																																									
Symbol	Truth Table	Symbol	Truth Table	Symbol	Truth Table																																																																																																				
	<table border="1" style="margin: auto;"> <tr><th colspan="2">IN</th><th>OUT</th></tr> <tr><td>A</td><td>B</td><td>Y</td></tr> <tr><td>0</td><td>0</td><td>0</td></tr> <tr><td>0</td><td>1</td><td>0</td></tr> <tr><td>1</td><td>0</td><td>0</td></tr> <tr><td>1</td><td>1</td><td>1</td></tr> </table>	IN		OUT	A	B	Y	0	0	0	0	1	0	1	0	0	1	1	1		<table border="1" style="margin: auto;"> <tr><th colspan="2">IN</th><th>OUT</th></tr> <tr><td>A</td><td>B</td><td>Y</td></tr> <tr><td>0</td><td>0</td><td>0</td></tr> <tr><td>0</td><td>1</td><td>1</td></tr> <tr><td>1</td><td>0</td><td>0</td></tr> <tr><td>1</td><td>1</td><td>0</td></tr> </table>	IN		OUT	A	B	Y	0	0	0	0	1	1	1	0	0	1	1	0		<table border="1" style="margin: auto;"> <tr><th colspan="2">IN</th><th>OUT</th></tr> <tr><td>A</td><td>B</td><td>Y</td></tr> <tr><td>0</td><td>0</td><td>1</td></tr> <tr><td>0</td><td>1</td><td>1</td></tr> <tr><td>1</td><td>0</td><td>1</td></tr> <tr><td>1</td><td>1</td><td>0</td></tr> </table>	IN		OUT	A	B	Y	0	0	1	0	1	1	1	0	1	1	1	0																																														
IN		OUT																																																																																																							
A	B	Y																																																																																																							
0	0	0																																																																																																							
0	1	0																																																																																																							
1	0	0																																																																																																							
1	1	1																																																																																																							
IN		OUT																																																																																																							
A	B	Y																																																																																																							
0	0	0																																																																																																							
0	1	1																																																																																																							
1	0	0																																																																																																							
1	1	0																																																																																																							
IN		OUT																																																																																																							
A	B	Y																																																																																																							
0	0	1																																																																																																							
0	1	1																																																																																																							
1	0	1																																																																																																							
1	1	0																																																																																																							
NOT GATE																																																																																																									
Symbol			Truth Table																																																																																																						
 <p style="text-align: center;">Inverter (NOT)</p>			<table border="1" style="margin: auto;"> <tr><th>IN</th><th>OUT</th></tr> <tr><td>A</td><td>Y</td></tr> <tr><td>0</td><td>1</td></tr> <tr><td>1</td><td>0</td></tr> </table>			IN	OUT	A	Y	0	1	1	0																																																																																												
IN	OUT																																																																																																								
A	Y																																																																																																								
0	1																																																																																																								
1	0																																																																																																								

Figure 1 - Logic Gates

Notes:

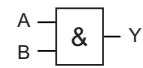
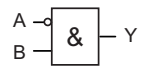
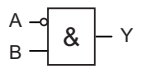
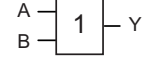
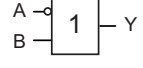
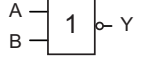
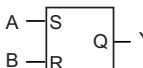
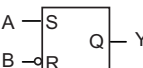

Customer Care Centre

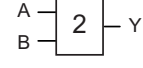
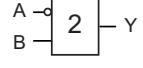
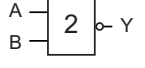
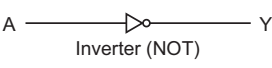
<http://www.schneider-electric.com/CCC>

Schneider Electric

35 rue Joseph Monier
92506 Rueil-Malmaison
FRANCE

Phone: +33 (0) 1 41 29 70 00

Fax: +33 (0) 1 41 29 71 00

www.schneider-electric.com

Publication: P821/EN T/J31

Publishing: Schneider Electric

05/2017