

MiCOM P591, P593, P594 & P595

Interface Units



The MiCOM P59x interface units are designed to meet a wide range of communications standards suitable for application on a number of communications systems such as fibre optic, microwave and pilot wires.

The MiCOM P591, and P593 units are stand alone fibre optic to electrical communications interface units that allow the P54x and P52x current differential relays to be connected to remote pulse code modulation (PCM) multiplexing equipment, using 64 kbit/sec data channels conforming to ITU-T recommendations V.35, G.703 or X.21.

MiCOM P594 GPS synchronizing module allows GPS time synchronization for the P545 and P546 current differential relays when used in Synchronous Digital Hierarchy (SDH)/ Synchronous Optical Network (SONET) communications applications.

The MiCOM P595 provides secure communications on unconditioned twisted pair pilot wires for use with P52x current differential relays. The interfacing device accepts EIA(RS)485 from the P521 and uses an internal modem to drive a 4-wire signalling link, ensuring fast operation of the differential protection.

The P59x units provide functions for simple diagnostics and testing and are easily configured via switches.



CUSTOMER BENEFITS

- Flexibility to use current differential protection over integrated services digital network (ISDN), multiplexers and modem connections
- Loopback facilities to simplify the differential scheme test
- Provide a precise GPS time synchronization to apply P545/P546 differential relays in SDH/SONET networks.
- Visual indication for easy diagnostic and testing

MODELS AVAILABLE

- > **P591** - Fibre optic to electrical signal G.703 co- directional
- > **P593** - Fibre optic to electrical signal X.21
- > **P594** - GPS synchronising timing module for P545 and P546 relays
- > **P595** - EIA(RS)485 to pilot wire interface for relay connection to unconditioned twisted pair pilots

APPLICATION

One MiCOM P591 or P593 unit is required per data channel (ie. for each transmit and receive signal pair).

The interface unit is usually located close to the PCM multiplexer and provides optical-to-electrical and electrical-to-optical signal conversion between a MiCOM P54x or P52x relay and the PCM multiplexer. The relay and PCM multiplexing equipment can be up to 1km apart, and interconnected by 850nm multi-mode fibre cables.

The P543 to P546 relays may be deployed on communications links where the multiplexer interfaces to a Synchronous Digital Hierarchy (SDH or SONET).

In such applications the conventional propagation delay measurement may be unreliable due to switching, and GPS time synchronization is required. A MiCOM P594 interface unit can provide synchronizing signals for up to 4 MiCOM relays within a substation.

The GPS module P594 and the relay can be up to 1km apart. Note: The length of the fibre optic cable between the relay and timing module at one end of the system must not differ by more than 0.5km to that at the other end, as this could introduce timing problems.

A P594 module must be deployed at each line terminal, to be connected by a coaxial cable to a GPS antenna and also by a single 850nm fibre to the P545/P546 relay.

The MiCOM P595 is for use with the MiCOM P521 relays on 4-wire unconditioned pilot wires for distances up to 25km between relay ends. Using specified minimum pilot wire parameters, secure and reliable data speeds of up to 19.2kbps are realised. An EIA(RS)485 port for relay connection up to 3m as well as an optional fibre optic port for longer distances are available.

The P591/3/4 MiCOM interface units are housed in a 20 TE MiCOM case and are suitable for flush mounting. The P595 is housed in an aluminium case suitable for surface or flush mounting.

FIBRE OPTIC CONNECTIONS TO MiCOM P54x/P52x

Fibre optic connections between the relay and interface units are made through BFOC 2.5 (ST®) type connectors. The optical devices used are designed for short-haul communications and operate with a nominal wavelength of 850nm. The levels of fibre optic radiation emitted from the interface units are not hazardous.

Connections to G.703

ITU-T G.703 co-directional electrical connections to the P591 interface unit are via the terminal blocks on the rear of the device. The G.703 signals are isolated by pulse transformers to 1kV. Since the G.703 signals are only ±1V magnitude, the cable connecting the P591 unit and the multiplexer must be properly screened against electromagnetic noise and interference.

The interface cable should consist of pairs of 24AWG (19/0.12mm), twisted and shielded, and have a characteristic impedance of about 120 ohms. The choice of grounding depends on the local codes and practices.

It is recommended that the interface cable shield is connected to the multiplexer frame ground. The cable may be connected to the MiCOM P591 case ground if no ground loop current is expected.

External connections of the P591 are shown in Fig.1.

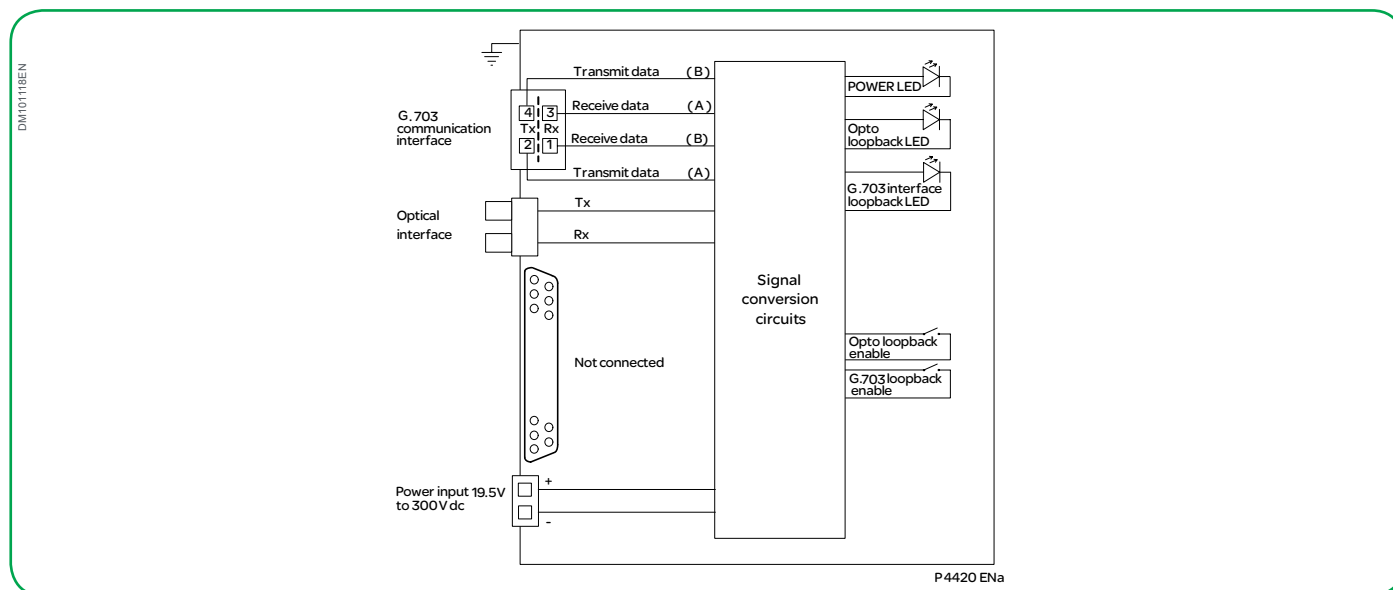

Figure 1
P591 connection to IUT-T G.703 (co-directional)

Connections to X.21

ITU-T X.21 electrical connections to the P593 interface unit are made via a D-subminiature connector on the rear of the device.

The use of twisted pairs of 24 AWG (19/0.12mm) stranded cable, foil shielded, with drain wire is recommended.

Due to the similarities between EIA449 and X.21, the P593 may also be suitable for connection to EIA449/EIA422 equipment.

External connections of the P593 are shown in Fig 2.

Connections to GPS Antenna

The antenna supplied by Schneider Electric is a MOTOROLA ONCORE™ TIMING2000. The P594 kit includes all the parts required for its installation ; antenna, the antenna cable, lightning arrester, amplifier (if needed), mounting instructions and all the additional parts required for its installation.

The standard P594 kit comes with 25 metres of antenna cable. Should a longer antenna cable be required, a 50 metres antenna cable P594 kit is available and can be requested with the order.

External connections of the P594 are shown in Fig. 3.

Pilot wire connections to P52x

EIA(RS)485 electrical connections to the P595 interface unit are via the terminal blocks on the bottom of the device and are suitable for 3m length screened cable connections to the relay . The EIA(RS)485 serial interface signals are converted internally to EIA(RS)232-level signals.

A modem designed for transmission of measuring signals over twisted pair pilot wires is connected in series with the level converter.

The pilot wire interface has an isolation level of 1.5kV but external isolating transformers with an isolating level of 10/20kV may be connected in series with the modem if required.

The unconditioned pilot wire should consist of two pairs of 0.4mm(26AWG) up to a maximum of 0.9mm(19AWG), twisted and shielded interface cable to ensure secure and reliable communications.

External connections of the P595 are shown in Fig. 4

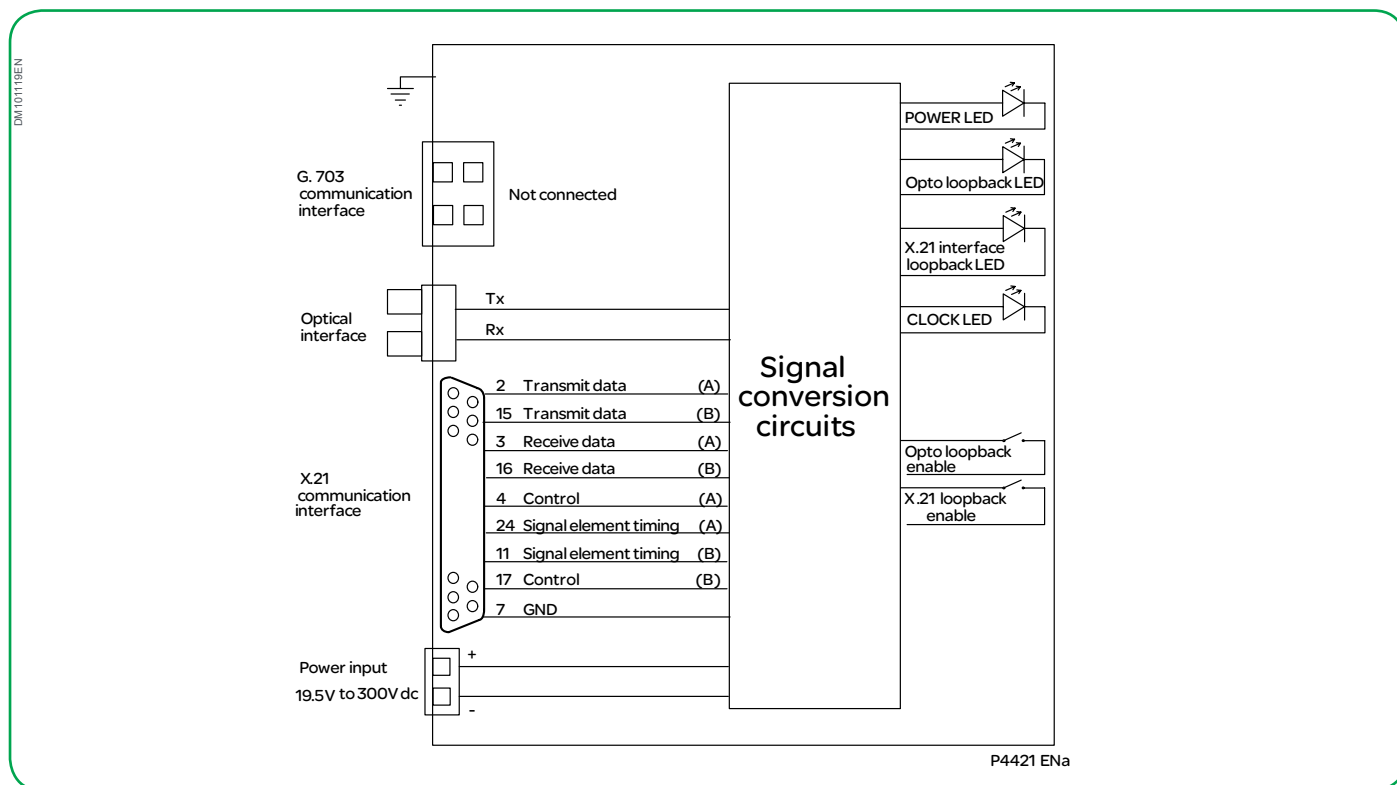

Figure 2
P593 connection to ITU-T X.21

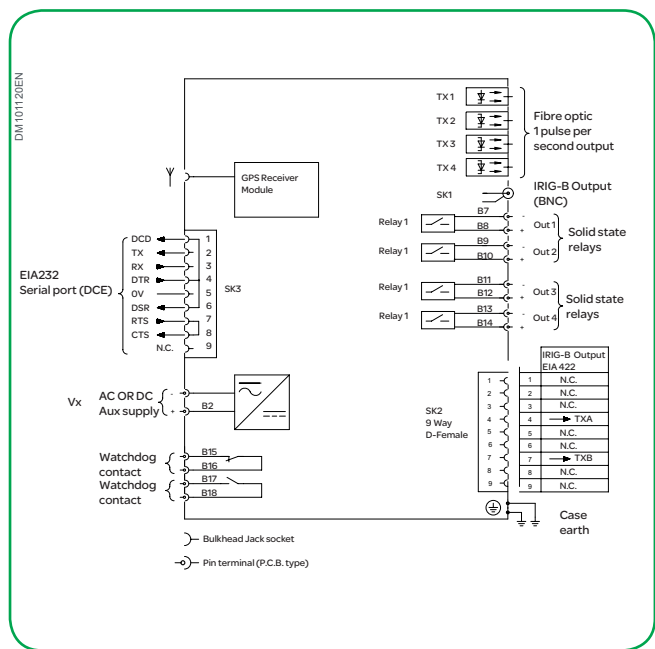

Figure 3
P594 connections (GPS timing modules)

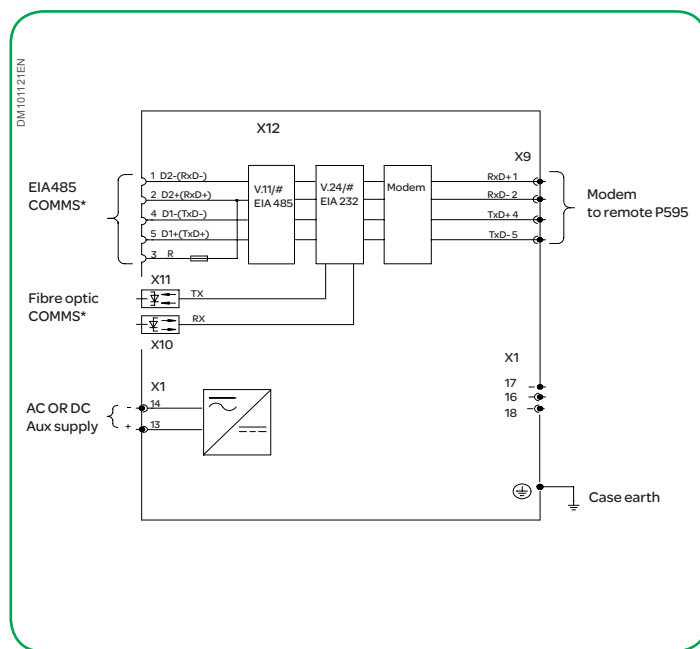

Figure 4
P595 connections

MiCOM P591, P593, P594 & P595: HOW TO ORDER?

Models	Ordering code	Description	Dimension (mm)
P591	E591601A0N0000B	Universal	51 x 177 x 238 (10TE)
P593	E593601A0N0000B	Universal	51 x 177 x 238 (10TE)
P594	E594150001D E594250001D E594350001D E5940025 E5940050 E5940100	24-48 Vdc * 48-125 Vdc & 35-100Vac * 110-250 Vdc & 100-240Vac * P594 antenna kit with 25m cable P594 antenna kit with 50m cable P594 antenna kit, amplifier, 100m cable	103 x 177 x 238 (20TE)
P595	E5951510A E5951540A	60-250 Vdc & 100-230 Vac - Cable connection 60-250 Vdc & 100-230 Vac - Fibre connection	309 x 176 x 93

* = English, French, German & Spanish

Schneider Electric Industries SAS

35, rue Joseph Monier
CS 30323
F - 92506 Rueil Malmaison Cedex (France)
Tel.: +33 (0) 1 41 29 70 00
RCS Nanterre 954 503 439
Capital social 896 313 776 €
www.schneider-electric.com

As standards, specifications and designs change from time to time, please ask for confirmation of the information given in this publication.

Design: Schneider Electric Industries SAS - Sonovision
Photos: Schneider Electric Industries SAS
Printed: Altavia Connexion - Made in France

